

## GROUP 34

# REAR SUSPENSION

## CONTENTS

<b>GENERAL DESCRIPTION</b> .....	<b>34-2</b>	<b>SHOCK ABSORBER, COIL SPRING AND LOWER ARM ASSEMBLY</b> .....	<b>34-15</b>
<b>REAR SUSPENSION DIAGNOSIS</b> ..	<b>34-2</b>	REMOVAL AND INSTALLATION .....	34-15
INTRODUCTION TO REAR SUSPENSION DIAGNOSIS .....	34-2	LOWER ARM BUSHING REPLACEMENT ..	34-17
REAR SUSPENSION DIAGNOSIS TROUBLESHOOTING STRATEGY .....	34-3	<b>STABILIZER BAR</b> .....	<b>34-17</b>
SYMPTOM CHART.....	34-3	REMOVAL AND INSTALLATION.....	34-17
SYMPTOM PROCEDURES .....	34-3	INSPECTION.....	34-18
<b>SPECIAL TOOLS</b> .....	<b>34-5</b>	STABILIZER LINK BALL JOINT DUST COVER REPLACEMENT .....	34-19
<b>ON-VEHICLE SERVICE</b> .....	<b>34-6</b>	<b>TOE CONTROL ARM ASSEMBLY AND TOE CONTROL TOWER BAR</b> .....	<b>34-20</b>
REAR WHEEL ALIGNMENT CHECK AND ADJUSTMENT .....	34-6	REMOVAL AND INSTALLATION .....	34-20
UPPER ARM BALL JOINT END PLAY CHECK .....	34-7	INSPECTION.....	34-22
TOE CONTROL ARM BALL JOINT END PLAY CHECK.....	34-7	TOE CONTROL ARM BALL JOINT DUST COVER REPLACEMENT .....	34-22
BALL JOINT DUST COVER CHECK .....	34-7	<b>TRAILING ARM ASSEMBLY</b> .....	<b>34-23</b>
<b>REAR SUSPENSION ASSEMBLY</b> ..	<b>34-8</b>	REMOVAL AND INSTALLATION .....	34-23
REMOVAL AND INSTALLATION.....	34-8	TRAILING ARM BUSHING REPLACEMENT .....	34-24
INSPECTION .....	34-10	<b>SPECIFICATIONS</b> .....	<b>34-24</b>
<b>UPPER ARM ASSEMBLY</b> .....	<b>34-11</b>	FASTENER TIGHTENING SPECIFICATIONS .....	34-24
REMOVAL AND INSTALLATION .....	34-11	GENERAL SPECIFICATIONS .....	34-25
INSPECTION.....	34-13	SERVICE SPECIFICATIONS .....	34-25
BALL JOINT DUST COVER REPLACEMENT.....	34-14		

## GENERAL DESCRIPTION

M1341000100234

This is a multi-link type double wishbone independent rear suspension. Because the left and right wheels move independently with almost no change in tire posture, the tires contact the ground firmly, providing excellent steering stability as well as improved riding comfort.

### CONSTRUCTION DIAGRAM

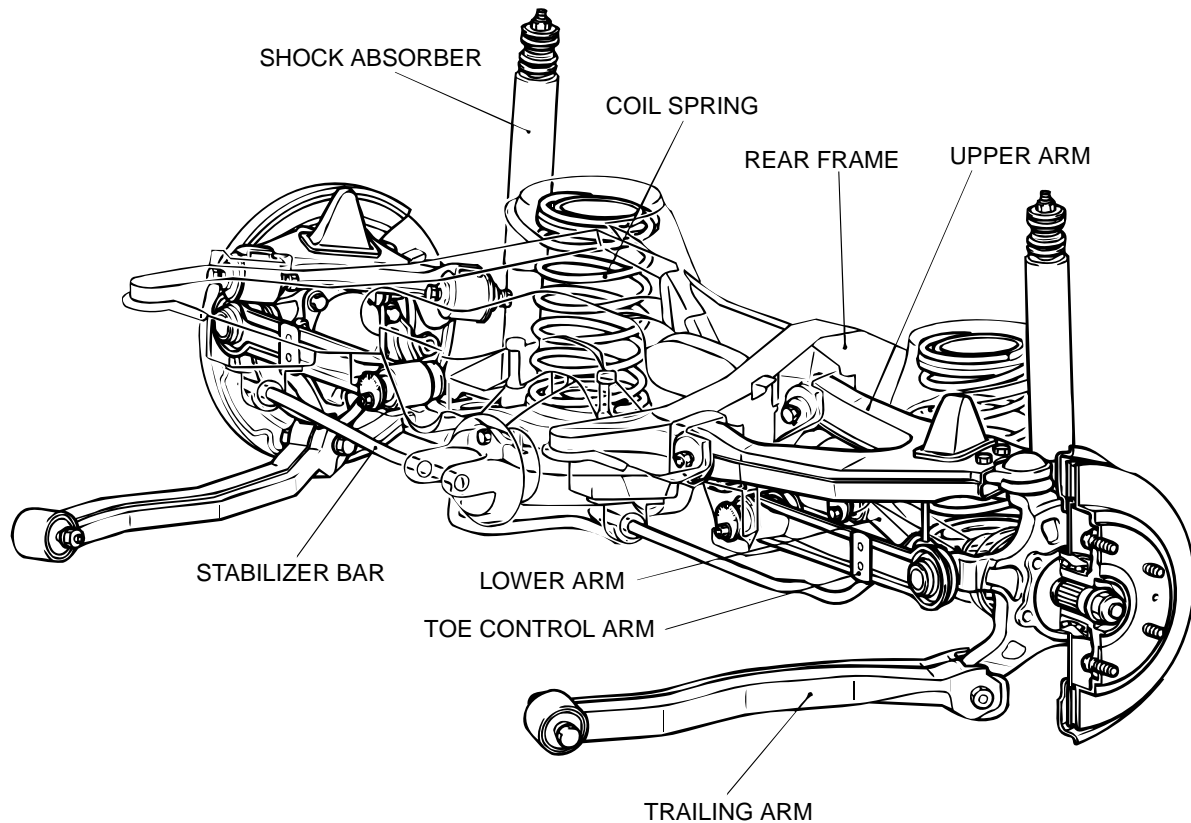

AC000043 AB

## REAR SUSPENSION DIAGNOSIS

### INTRODUCTION TO REAR SUSPENSION DIAGNOSIS

M1341013100182

If the rear suspension is faulty, the vehicle will not run straightforward or noise will occur. Incorrect wheel alignment, malfunction of shock absorber, stabilizer bar, coil spring, control arms or out-of-balance tires can cause these problems.

## REAR SUSPENSION DIAGNOSIS TROUBLESHOOTING STRATEGY

M1341013200189

Use these steps to plan your diagnostic strategy. If you follow them carefully, you will be sure that you have exhausted most of the possible ways to find a rear suspension fault.

1. Gather information from the customer.

2. Verify that the condition described by the customer exists.
3. Find the malfunction by following the Symptom Chart.
4. Verify malfunction is eliminated.

## SYMPTOM CHART

M1341013500210

SYMPTOM	INSPECTION PROCEDURE	REFERENCE PAGE
Squeaks or other abnormal noise	1	P.34-3
Poor ride	2	P.34-4
Body tilting	3	P.34-4

## SYMPTOM PROCEDURES

### INSPECTION PROCEDURE 1: Squeaks or Other Abnormal Noise

#### DIAGNOSIS

**STEP 1. Check for loose rear suspension installation bolts and nuts.**

**Q: Are the rear suspension installation bolts and nuts loose?**

**YES :** Retighten, then go to Step 6.

**NO :** Go to Step 2.

**STEP 2. Check for malfunction of shock absorber (worn bushings).**

**Q: Is the shock absorber (bushings) in good condition?**

**YES :** Go to Step 3.

**NO :** Replace it, then go to Step 6.

**STEP 3. Check the upper arms and/or toe control arms for deformity or damage.**

**Q: Are the upper arms and/or toe control arms in good condition?**

**YES :** Go to Step 4.

**NO :** Replace it, then go to Step 6.

**STEP 4. Check the trailing arms for deformity or damage.**

**Q: Are the trailing arms in good condition?**

**YES :** Go to Step 5.

**NO :** Replace it, then go to Step 6.

**STEP 5. Check the rear frame for deformations or damage.**

**Q: Is the rear frame deformed or damaged?**

**YES :** Adjust or replace it, then go to Step 6.

**STEP 6. Retest the system.**

**Q: Is the malfunction eliminated?**

**YES :** The procedure is complete.

**NO :** Return to Step 1.

---

**INSPECTION PROCEDURE 2: Poor Ride**

---

**DIAGNOSIS**

---

**STEP 1. Check for excessive tire inflation pressure.**

**Q: Is the tire inflation pressure correct?**

**YES :** Go to Step 2.

**NO :** Adjust the pressure, then go to Step 4.

---

**STEP 2. Check for malfunction of shock absorber (weak or broken springs).**

**Q: Is the shock absorber in good condition?**

**YES :** Go to Step 3.

**NO :** Replace it, then go to Step 4.

---

**STEP 3. Check the stabilizer bar and/or stabilizer link for deformity or damage.**

**Q: Is the stabilizer bar and/or stabilizer link deformed or damaged?**

**YES :** Go to Step 4.

**NO :** Replace it, then go to Step 4.

---

**STEP 4. Retest the system.**

**Q: Is the malfunction eliminated?**

**YES :** The procedure is complete.

**NO :** Return to Step 1.

---

**INSPECTION PROCEDURE 3: Body Tilting**

---

**DIAGNOSIS**

---

**STEP 1. Check for weak or deteriorated bushings.**

**Q: Are the bushings in good condition?**

**YES :** Go to Step 2.

**NO :** Replace it, then go to Step 6.

---

**STEP 2. Check for weak or broken springs.**

**Q: Are the springs in good condition?**

**YES :** Go to Step 3.

**NO :** Replace it, then go to Step 6.

---

**STEP 3. Check the upper arms and/or lower arms and/or toe control arms for deformity or damage.**

**Q: Are the upper arms and/or lower arms and/or toe control arms deformed or damaged?**

**YES :** Replace it, then go to Step 6.

**NO :** Go to Step 4.

---

**STEP 4. Check the trailing arms for deformity or damage.**

**Q: Are the trailing arms deformed or damaged?**

**YES :** Replace it, then go to Step 6.

**NO :** Go to Step 5.

---

**STEP 5. Check the rear frame for deformity or damage.**

**Q: Is the rear frame deformed or damaged?**

**YES :** Replace it, then go to Step 6.

**NO :** Go to Step 6.

---

**STEP 6. Retest the system.**



**Q: Is the malfunction eliminated?**

**YES :** The procedure is complete.

**NO :** Return to Step 1.

**SPECIAL TOOLS**

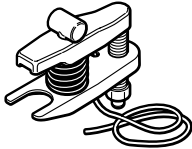
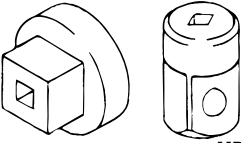
M1341000600262

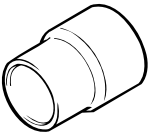
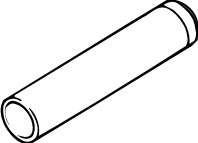
TOOL	TOOL NUMBER AND NAME	SUPERSESION	APPLICATION
 <p>AC106827</p>	<p>MB991897 Ball joint remover</p>	<p>MB991113-01, MB990635-01 or General service tool</p>	<p>Ball joint disconnection <i>NOTE: Steering linkage puller (MB990635 or MB991113) is also available to disconnect ball joint.</i></p>
 <p>MB990326</p>	<p>MB990326 Preload socket</p>	<p>General service tool</p>	<p>Ball joint turning torque check</p>
 <p>MB990799</p>	<p>MB990799 Ball joint dust cover installer</p>	<p>MB990799-01</p>	<p>Upper arm ball joint dust cover installation</p>
 <p>MB990881</p>	<p>MB990881 Rear suspension bushing arbor</p>	<p>–</p>	<p>Lower arm bushing removal and press-fitting</p>
 <p>MB990799</p>	<p>MB990800 Ball joint remover and installer</p>	<p>MB990800-01 or General service tool</p>	<p>Toe control arm ball joint dust cover installation</p>
	<p>MD998236 Output shaft bearing installer</p>	<p>–</p>	<p>Trailing arm bushing removal and press-fitting</p>

**ON-VEHICLE SERVICE****REAR WHEEL ALIGNMENT CHECK AND  
ADJUSTMENT**

M1341011000264

1. The front suspension, steering system and wheel and tires must be serviced to normal condition before measuring the wheel alignment.
2. Measure the wheel alignment with the vehicle parked on a level surface.

**Toe-in****Standard value:  $3 \pm 3$  mm ( $0.12 \pm 0.12$  inch)**

If toe-in is not within the standard value, adjust as follows.

1. Be sure to adjust the camber before making toe adjustment.
2. Adjust by turning the toe adjusting bolt (toe control arm mounting bolt which faces the inside of the body).

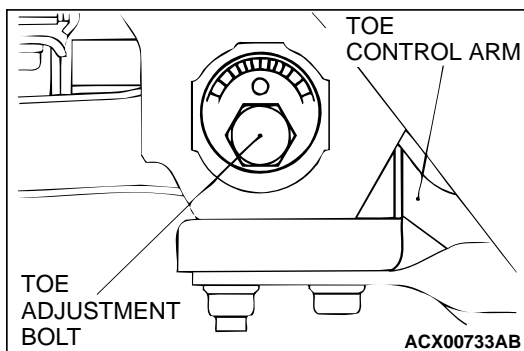
**Left wheel: Turning clockwise (-) toe-in****Right wheel: Turning clockwise (+) toe-in****Camber****Standard value:  $0^\circ \pm 30'$  (difference between right and left wheels: less than  $30'$ )**

Use the compensator to measure camber.

If camber is not within the standard value, adjust by following procedures.

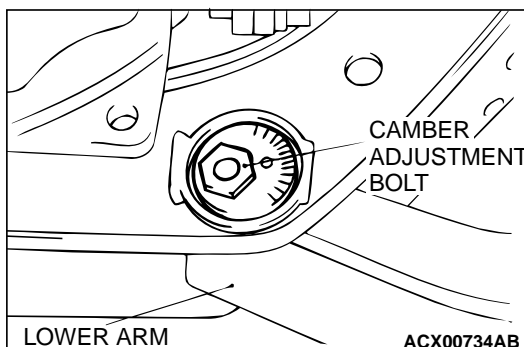
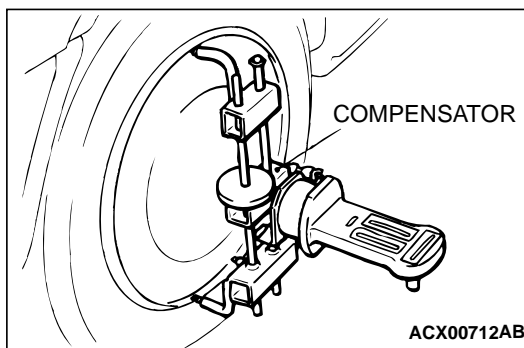

1. Adjust by turning the camber adjusting bolt of the lower arm.  
**Left wheel: Turning clockwise (-) camber**  
**Right wheel: Turning clockwise (+) camber**
2. After adjusting the camber, the toe-in should be adjusted.

---

**UPPER ARM BALL JOINT END PLAY CHECK**

M1341015900021

1. Raise the vehicle.
2. Move the upper arm up and down with your hands to check for an excessive play in the axial direction of the ball joint. If there is an excessive play, replace the upper arm ball joint.

**TOE CONTROL ARM BALL JOINT END PLAY CHECK**

M1341015800046

1. Raise the vehicle.
2. Move the toe control arm front and rear with your hands. If there is an excessive play, replace the toe control arm assembly.

**BALL JOINT DUST COVER CHECK**

M1341012800199

1. Inspect the dust cover for cracks or damage by pushing it with your finger.
2. If the dust cover is cracked or damaged, replace the upper arm ball joint assembly, toe control arm ball joint assembly or the stabilizer link.

*NOTE: If the dust cover is cracked or damaged, it is possible that there may also be damage to the ball joint.*

## REAR SUSPENSION ASSEMBLY

## REMOVAL AND INSTALLATION

M1341001000122

**CAUTION**

\*: Indicates parts which should be temporarily tightened, and then fully tightened with the vehicle on the ground in the unladen condition.

**Post-installation Operation**

- Parking Brake Lever Stroke Check (Refer to GROUP 36, On-vehicle Service – Parking Brake Lever Stroke Check and Adjustment P.36-4.)
- Brake fluid refilling and air bleeding (Refer to GROUP 35A, On-vehicle Service P.35A-122.)
- Wheel Alignment Check and Adjustment (Refer to P.34-6.)

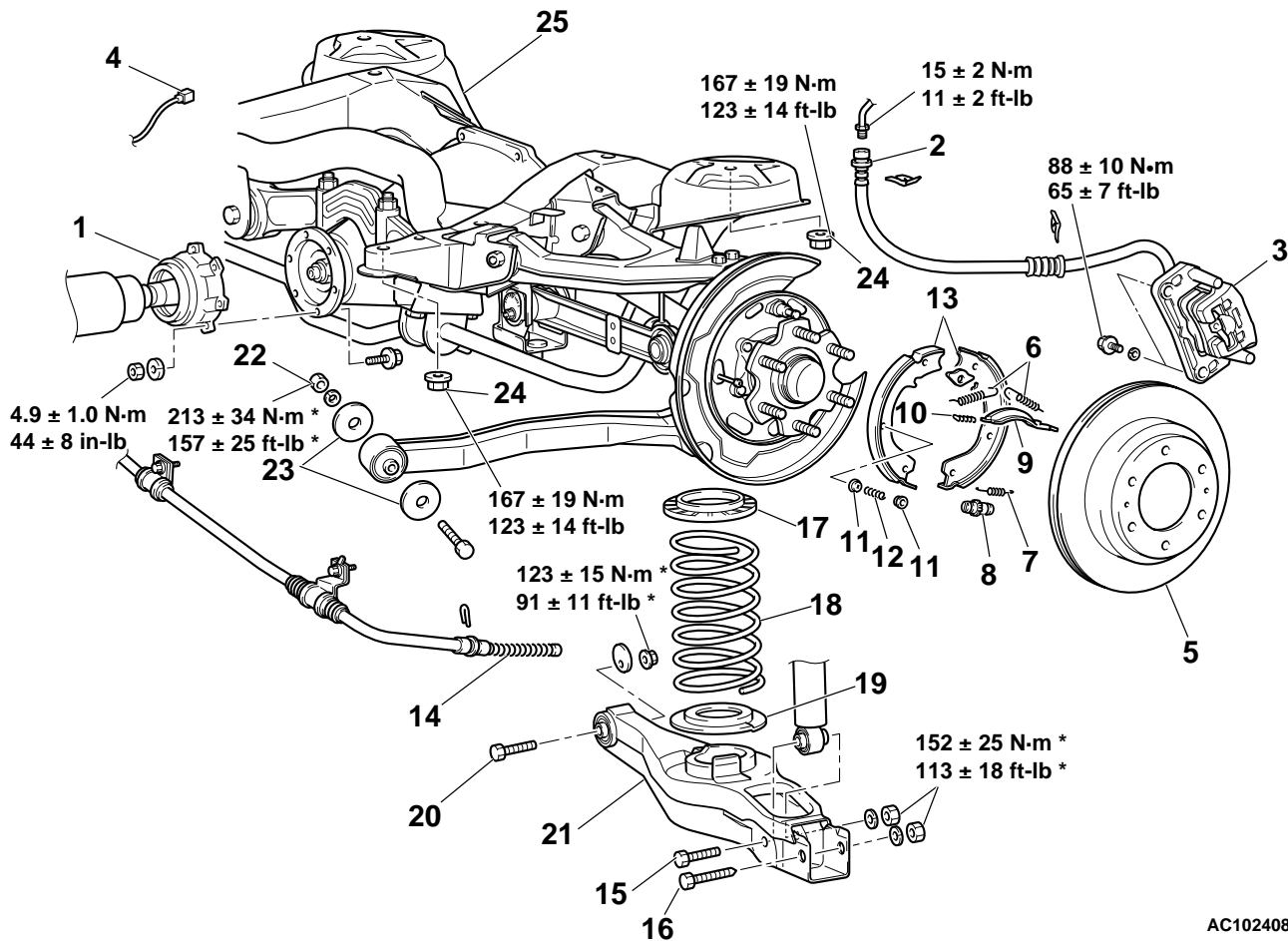

AC102408AB

**REMOVAL STEPS**

1. PROPELLER SHAFT CONNECTION (REFER TO GROUP 25, PROPELLER SHAFT P.36-7.)
  - BRAKE FLUID DRAINING
2. BRAKE LINE CONNECTION
3. BRAKE CALIPER ASSEMBLY
4. REAR WHEEL SPEED SENSOR CONNECTOR

**REMOVAL STEPS (Continued)**

5. BRAKE DISC
6. SHOE-TO-ANCHOR SPRING (REFER TO GROUP 36, PARKING BRAKE LINING AND DRUM P.36-7.)
7. ADJUSTING WHEEL SPRING (REFER TO GROUP 36, PARKING BRAKE LINING AND DRUM P.36-7.)

&lt;&lt;A&gt;&gt;



**REMOVAL STEPS (Continued)**

8. ADJUSTER ASSEMBLY (REFER TO GROUP 36, PARKING BRAKE LINING AND DRUM P.36-7.)
9. STRUT (REFER TO GROUP 36, PARKING BRAKE LINING AND DRUM P.36-7.)
10. SHOE-TO-SHOE SPRING (REFER TO GROUP 36, PARKING BRAKE LINING AND DRUM P.36-7.)
11. SHOE HOLD-DOWN CUP (REFER TO GROUP 36, PARKING BRAKE LINING AND DRUM P.36-7.)
12. SHOE HOLD-DOWN PIN (REFER TO GROUP 36, PARKING BRAKE LINING AND DRUM P.36-7.)
13. SHOE AND LINING ASSEMBLY (REFER TO GROUP 36, PARKING BRAKE LINING AND DRUM P.36-7.)
14. PARKING BRAKE CABLE CONNECTION
15. SHOCK ABSORBER MOUNTING BOLT
- <<B>> >>A<< 16. LOWER ARM MOUNTING BOLT
17. SPRING UPPER PAD
- >>A<< 18. COIL SPRING
19. SPRING LOWER PAD
- <<C>> 20. BOLT ASSEMBLY (CAMBER ADJUSTING BOLT)
21. LOWER ARM ASSEMBLY
22. TRAILING ARM MOUNTING NUT
23. STOPPER
- <<D>> 24. CROSSMEMBER MOUNTING NUT
25. REAR SUSPENSION ASSEMBLY

**REMOVAL SERVICE POINTS**

**<<A>> BRAKE CALIPER ASSEMBLY REMOVAL**

Secure the removed caliper assembly with a wire, so that it does not fall.

**<<B>> LOWER ARM MOUNTING BOLT REMOVAL**

1. Place a piece of wood at the lower arm as shown in the illustration. Using the floor jack, compress the coil spring to remove the lower arm mounting bolt.
2. Lower the floor jack slowly, and then remove the coil spring.

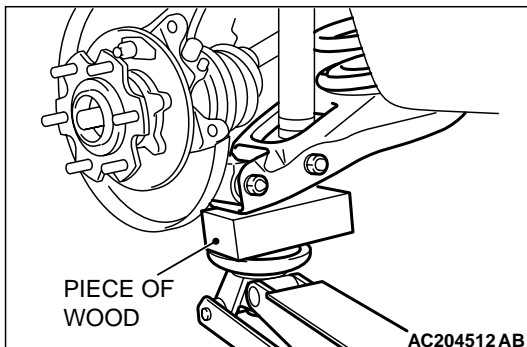

### <<C>> BOLT ASSEMBLY (CAMBER ADJUSTING BOLT) REMOVAL

Make the mating marks to the bracket and the camber adjusting bolt, and then remove the camber adjusting bolt.

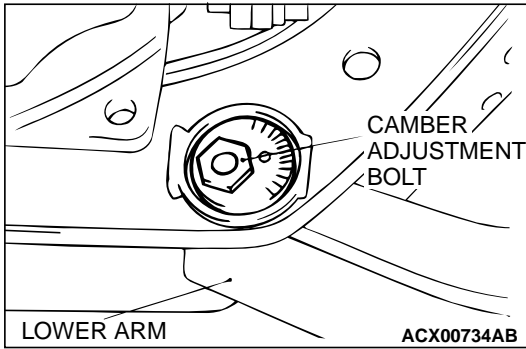

### <<D>> CROSSMEMBER MOUNTING NUT REMOVAL

Support the crossmember with a garage jack or transmission jack to remove the crossmember mounting nut.

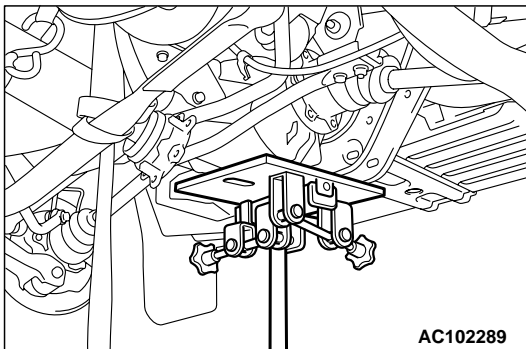

## INSTALLATION SERVICE POINT

### >>A<< COIL SPRING/LOWER ARM MOUNTING BOLT INSTALLATION

1. The identification color of the coil spring should be located at the lower side.
2. Align the coil spring end with the spring lower pad cavity.
3. Place a piece of wood at the lower arm as shown in the illustration. Using the floor jack, compress the coil spring to remove the lower arm mounting bolt.

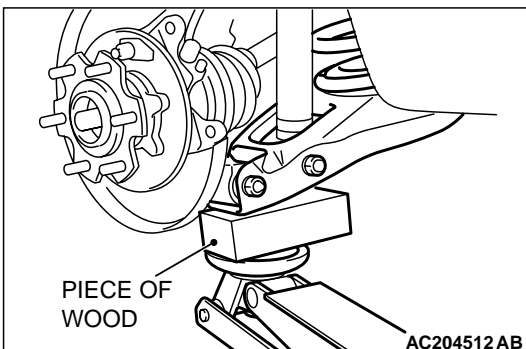

## INSPECTION

Check crossmember for cracks or other damage.

M1341015500067

# UPPER ARM ASSEMBLY

## REMOVAL AND INSTALLATION

M1341003600164

### Pre-removal Operations

- Brake Fluid Draining

### Post-installation Operations

- Press the dust cover with your finger to check that there are no cracks or damage in the dust cover.
- Brake fluid refilling and air bleeding (Refer to GROUP 35A, On-vehicle Service P.35A-122.)
- Wheel Alignment Check and Adjustment (Refer to P.34-6.)

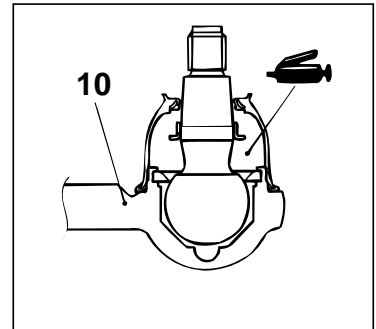
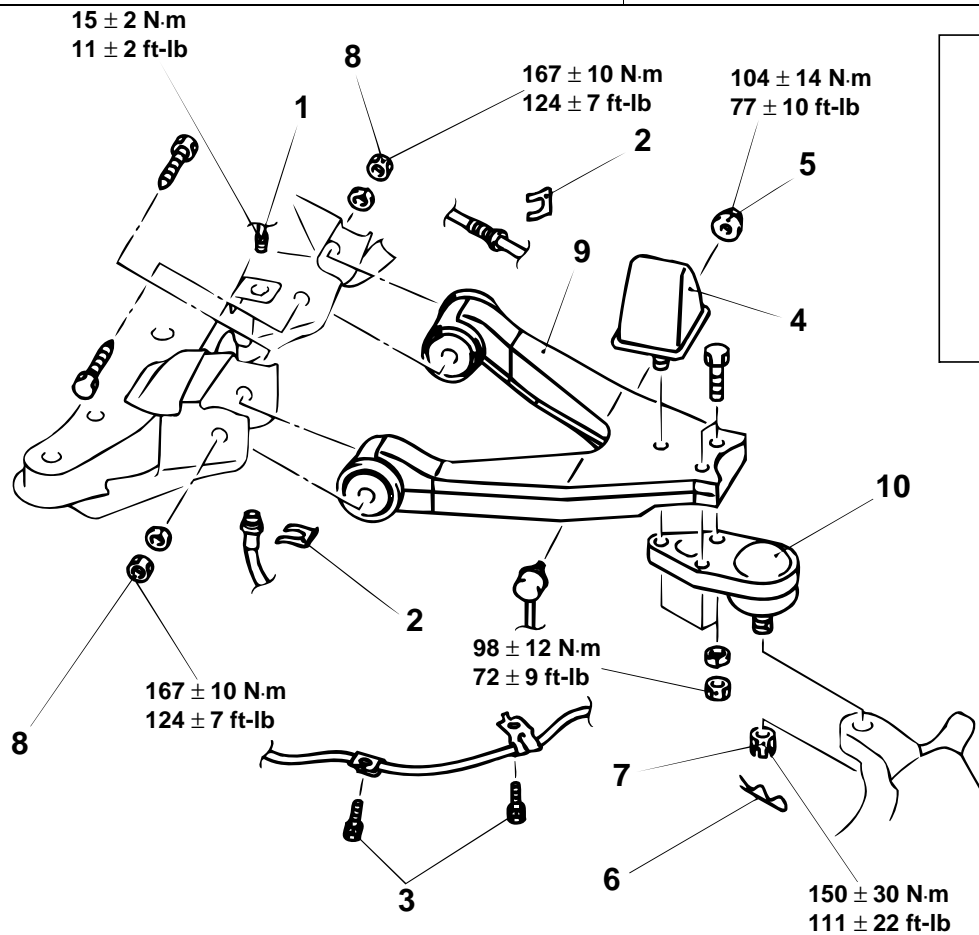

### REMOVAL STEPS

1. BRAKE PIPE CONNECTION
2. CLIP
3. REAR WHEEL SPEED SENSOR AND UPPER ARM ASSEMBLY CONNECTION.
4. BUMP STOPPER
5. STABILIZER LINK AND UPPER ARM ASSEMBLY CONNECTION.
6. COTTER PIN

### REMOVAL STEPS (Continued)

- <<A>> 7. UPPER ARM BALL JOINT AND KNUCKLE CONNECTION
- <<B>> >>A<< 8. UPPER ARM ASSEMBLY AND REAR FRAME CONNECTION
9. UPPER ARM
  10. UPPER ARM BALL JOINT

### Required Special Tool:

- MB991897: Ball Joint Remover

## REMOVAL SERVICE POINTS

## &lt;&lt;A&gt;&gt; UPPER ARM BALL JOINT AND KNUCKLE DISCONNECTION

**⚠ CAUTION**

- Do not remove the nut from ball joint. Loosen it and use special tool MB991897 to avoid possible damage to ball joint threads.
- Hang special tool MB991897 with a cord to prevent it from falling.

1. Install special tool MB991897 as shown in the figure.

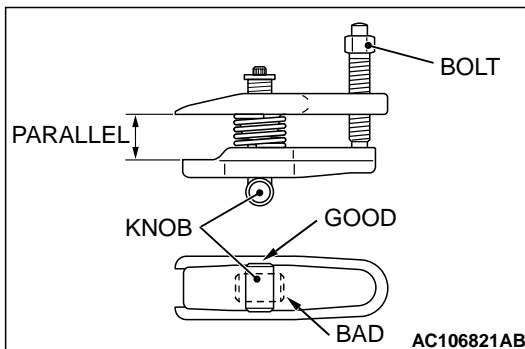
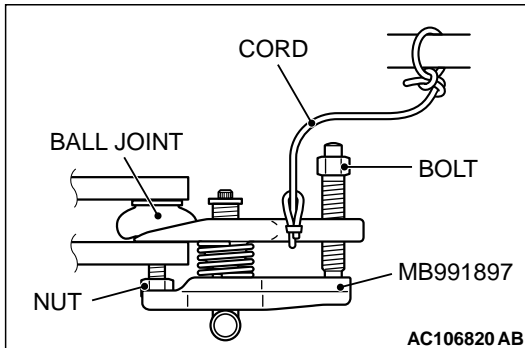

2. Turn the bolt and knob as necessary to make the jaws of special tool MB991897 parallel, tighten the bolt by hand and confirm that the jaws are still parallel.

*NOTE: When adjusting the jaws in parallel, make sure the knob is in the position shown in the figure.*

3. Tighten the bolt with a wrench to disconnect the ball joint.

## &lt;&lt;B&gt;&gt; UPPER ARM ASSEMBLY AND REAR FRAME DISCONNECTION

Disconnect the connection of the DOJ assembly and the companion shaft assembly.

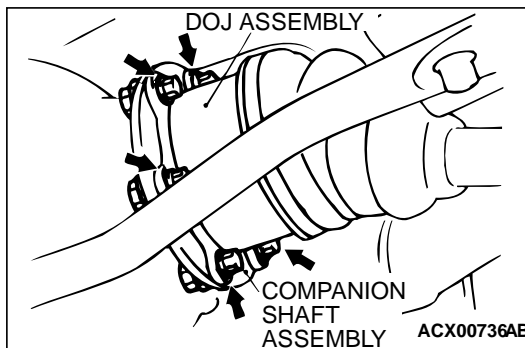

## INSTALLATION SERVICE POINT

### >>A<< UPPER ARM ASSEMBLY FROM REAR FRAME CONNECTION

After installing the upper arm mounting bolt, tighten the connecting bolt of the DOJ assembly and the companion shaft assembly to the specified torque  $113 \pm 14 \text{ N}\cdot\text{m}$  ( $84 \pm 10 \text{ ft}\cdot\text{lb}$ ).

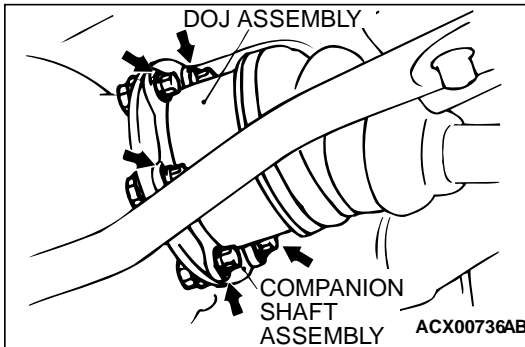

## INSPECTION

M1341015500078

- Check the bushing for wear and deterioration.
- Check the upper arm for bending or damage.
- Check all bolts for condition and straightness.

## UPPER ARM BALL JOINT TURNING TORQUE CHECK

### Required Special Tool:

- MB990326: Preload Socket

1. After shaking the ball joint stud several times, install the nut to the stud and use special tool MB990326 to measure the turning torque of the ball joint.

**Standard value: 1.5 – 7.9 N·m (13 – 70 in·lb)**

2. If the measured value exceeds the standard value, replace the upper arm ball joint assembly.
3. If the measured value is lower than the standard value, check that the upper arm ball joint turns smoothly without excessive play. If so, it is possible to use that ball joint.

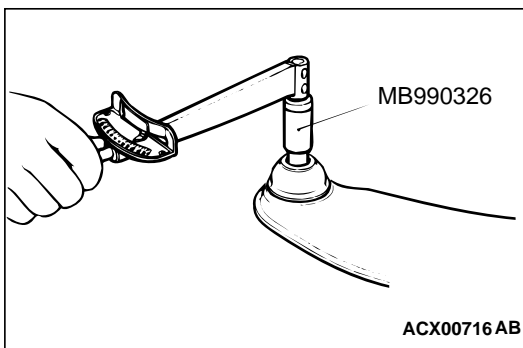

## UPPER ARM BALL JOINT DUST COVER CHECK

1. Press the dust cover with your finger to check that there are no cracks or damage in the dust cover.
2. If the dust cover is cracked or damaged, replace the upper arm ball joint assembly.

*NOTE: If the dust cover is cracked or damaged, it is possible that there may also be damage to the ball joint.*

*If it is damaged during service work, replace the dust cover.*

## BALL JOINT DUST COVER REPLACEMENT

M1341011700069

**Required Special Tool:**

- MB990799: Ball Joint Dust Cover Installer

If the dust cover is damaged accidentally during service work, replace the dust cover as follows:

1. Remove the dust cover.
2. Fill the inside of the dust cover with multipurpose grease as shown in the illustration.
3. Apply multipurpose grease to the dust cover and ball joint stud as shown in the illustration.
4. Wrap plastic tape around the lower arm ball joint stud, and then install the dust cover to the upper arm ball joint.

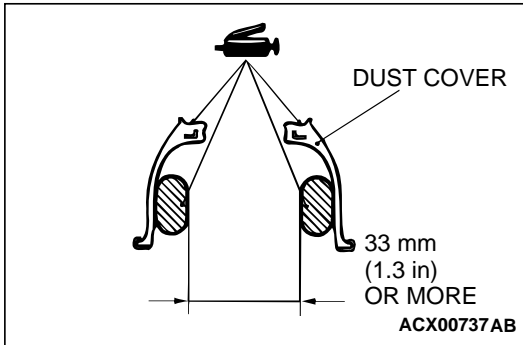
**CAUTION**

Do not apply grease to the place (tapered section) where the threaded section of the ball joint connects with the knuckle. Wipe the grease off if it is applied in this area. To prevent the grease to be applied on the ball joint connection (taper) with knuckle, do not compress the dust cover before installation.

5. Use special tool MB990799 to drive the dust cover into the shown position.
6. Press the dust cover with your finger to check that there are no cracks or damage in the dust cover.

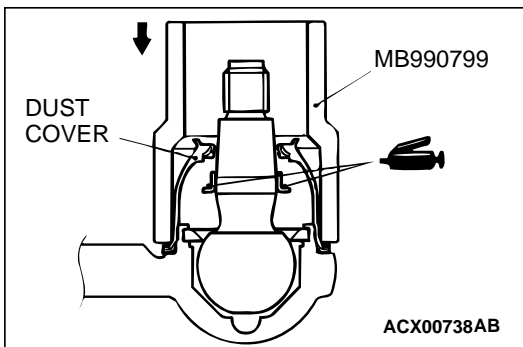

# SHOCK ABSORBER, COIL SPRING AND LOWER ARM ASSEMBLY

## REMOVAL AND INSTALLATION

M1341014200063

**CAUTION**

\*: indicates parts which should be temporarily tightened, and then fully tightened with the vehicle on the ground in the unladen condition.

**Post-removal Operation**

- Wheel Alignment Check and Adjustment (Refer to P.34-6.)

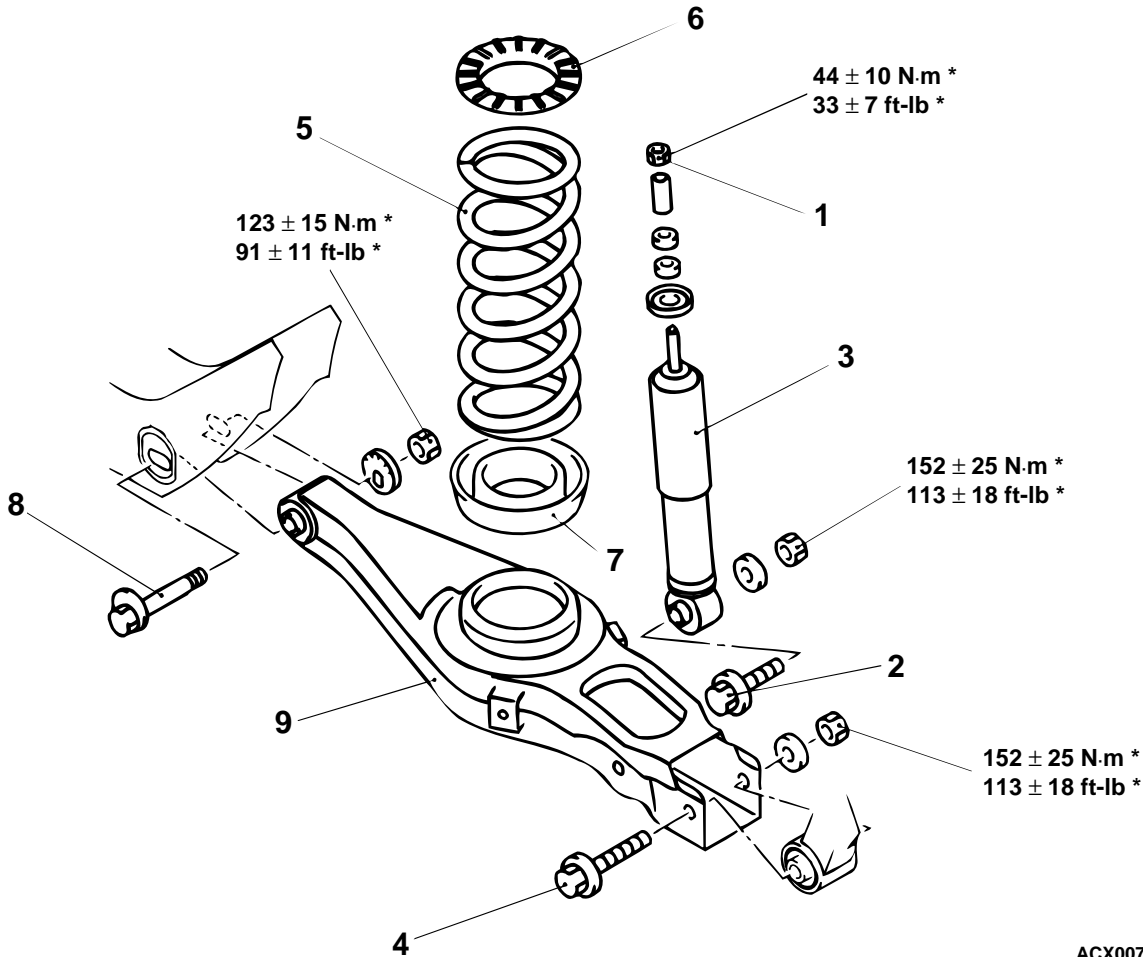

ACX00739 AB

**SHOCK ABSORBER REMOVAL STEPS**

1. SHOCK ABSORBER MOUNTING NUT
2. SHOCK ABSORBER MOUNTING BOLT
3. SHOCK ABSORBER

**COIL SPRING REMOVAL STEPS**

2. SHOCK ABSORBER MOUNTING BOLT
4. LOWER ARM MOUNTING BOLT
5. COIL SPRING

<<A>>>>A<<  
>>A<<

<<A>>>>A<<  
>>A<<

<<B>>

**COIL SPRING REMOVAL STEPS**

6. SPRING UPPER PAD
7. SPRING LOWER PAD

**LOWER ARM REMOVAL STEPS**

2. SHOCK ABSORBER MOUNTING BOLT
4. LOWER ARM MOUNTING BOLT
5. COIL SPRING
6. SPRING UPPER PAD
7. SPRING LOWER PAD
8. BOLT ASSEMBLY (CAMBER ADJUSTING BOLT)
9. LOWER ARM ASSEMBLY

### REMOVAL SERVICE POINTS

#### <<A>> LOWER ARM MOUNTING BOLT REMOVAL

1. Place a piece of wood at the lower arm as shown in the illustration. Using the floor jack, compress the coil spring to remove the lower arm mounting bolt.
2. Lower the floor jack slowly, and then remove the coil spring.

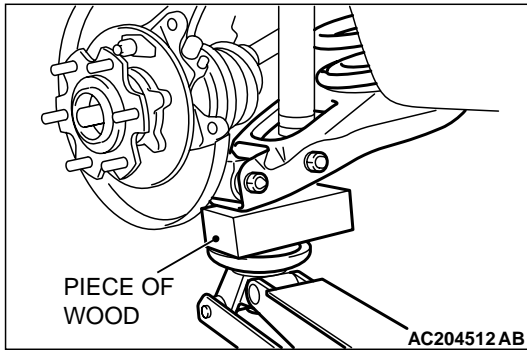

#### <<B>> BOLT ASSEMBLY (CAMBER ADJUSTING BOLT) REMOVAL

Make the mating marks to the bracket and the camber adjusting bolt, and then remove the camber adjusting bolt.

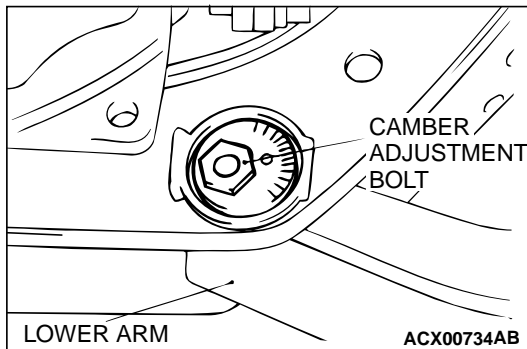

### INSTALLATION SERVICE POINT

#### >>A<< COIL SPRING/LOWER ARM MOUNTING BOLT INSTALLATION

1. The identification color of the coil spring should be located at the lower side.
2. Align the coil spring end with the spring lower pad cavity.
3. Place a piece of wood at the lower arm as shown in the illustration. Using the floor jack, compress the coil spring to remove the lower arm mounting bolt.

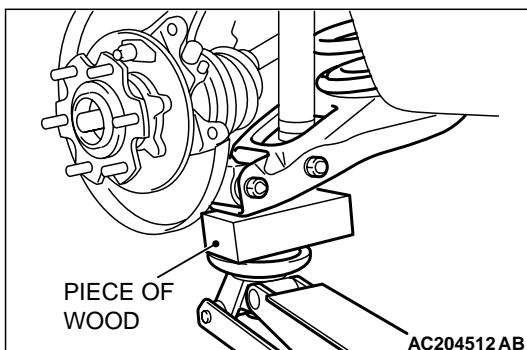



LOWER ARM BUSHING REPLACEMENT

M1341011800118

Required Special Tool:

- MB990881: Rear Suspension Bushing Arbor

Use special tool MB990881 to drive out and press-fit the lower arm bushing.

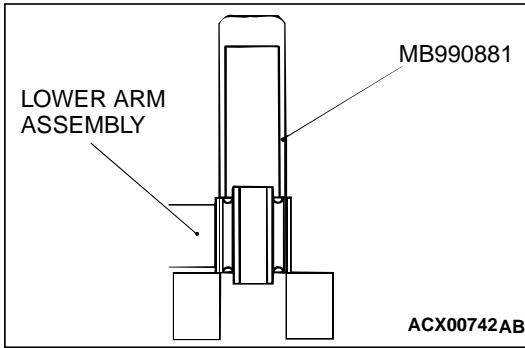

STABILIZER BAR

REMOVAL AND INSTALLATION

M1341001300093

Post-installation Operations

- Press the dust cover with your finger to check that there are no cracks or damage in the dust cover.

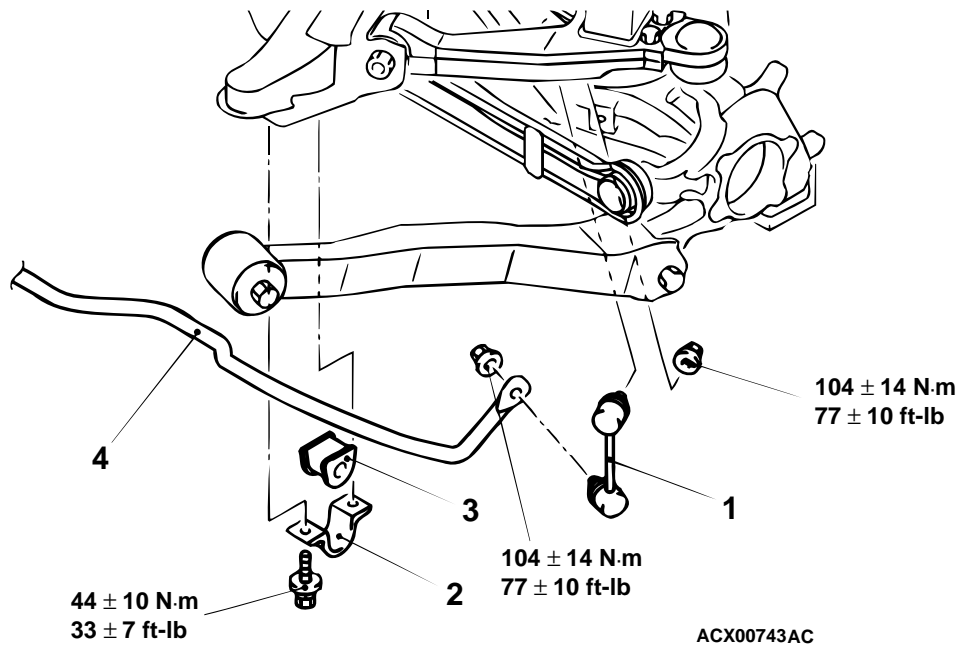
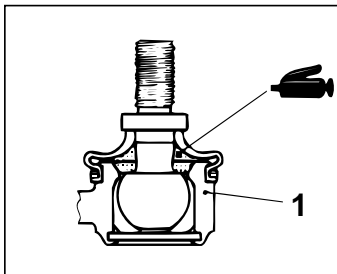

REMOVAL STEPS

1. STABILIZER LINK ASSEMBLY
2. STABILIZER CLAMP

REMOVAL STEPS (Continued)

- >>A<<
3. BUSHING
  4. STABILIZER BAR

## INSTALLATION SERVICE POINT

### >>A<< BUSHING INSTALLATION

1. Install the stabilizer bar so that its identification mark faces the left side of the vehicle.
2. Install the bushing so that its slit faces the direction shown in the illustration.

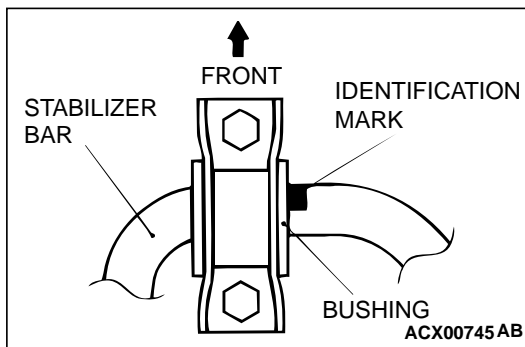
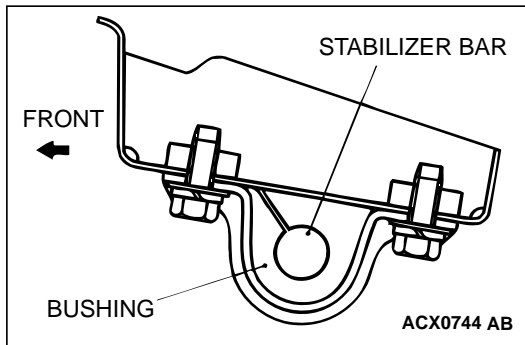

3. Before tightening the mounting bolts, align the end of the identification mark with the end of the bushing.

## INSPECTION

M1341015500089

- Check the bushing for wear and deterioration.
- Check the stabilizer bar for deterioration or damage.
- Check all bolts for condition and straightness.

## STABILIZER LINK BALL JOINT TURNING TORQUE CHECK

### Required Special Tool:

- MB990326: Preload Socket

1. After shaking the ball joint stud several times, install the nut to the stud and use special tool MB990326 to measure the turning torque of the ball joint.

**Standard value: 0.5 – 2.0 N·m (4 – 17 in-lb)**

2. If the measured value exceeds the standard value, replace the stabilizer link.
3. If the measured value is lower than the standard value, check that the ball joint turns smoothly without excessive play. If so, it is possible to use that ball joint.

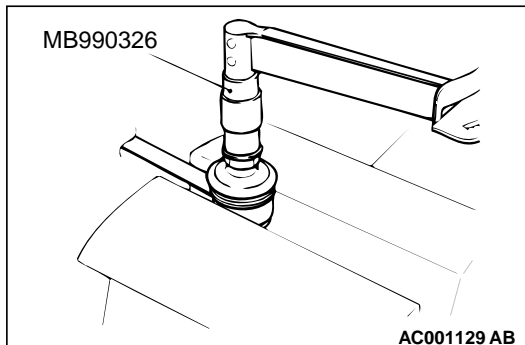

## STABILIZER LINK BALL JOINT DUST COVER CHECK

1. Press the dust cover with your finger to check that there are no cracks or damage in the dust cover.
2. If the dust cover is cracked or damaged, replace the stabilizer link.

*NOTE: If the dust cover is cracked or damaged, it is possible that there may also be damage to the ball joint. If it is damaged during service work, replace the dust cover.*

## STABILIZER LINK BALL JOINT DUST COVER REPLACEMENT

M1341010900112

If the dust cover is damaged accidentally during service work, replace the dust cover as follows:

1. Remove the clip ring, and then remove the dust cover.
2. Apply multipurpose grease to the inside of the dust cover.
3. Wrap plastic tape around the stabilizer link stud, and then install the dust cover to the stabilizer link.
4. Secure the dust cover in place with the clip ring.
5. Press the dust cover with your finger to check that there are no cracks or damage in the dust cover.

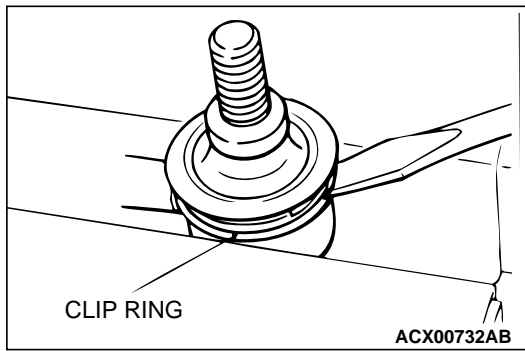

# TOE CONTROL ARM ASSEMBLY AND TOE CONTROL TOWER BAR

## REMOVAL AND INSTALLATION

M1341014500053

**CAUTION**

\*: Indicates parts which should be temporarily tightened, and then fully tightened with the vehicle on the ground in an unladen condition.

**Post-installation Operation**

- Check the dust cover for cracks or damage by pushing it with your finger.
- Wheel alignment check and adjustment (Refer to P.34-6.)

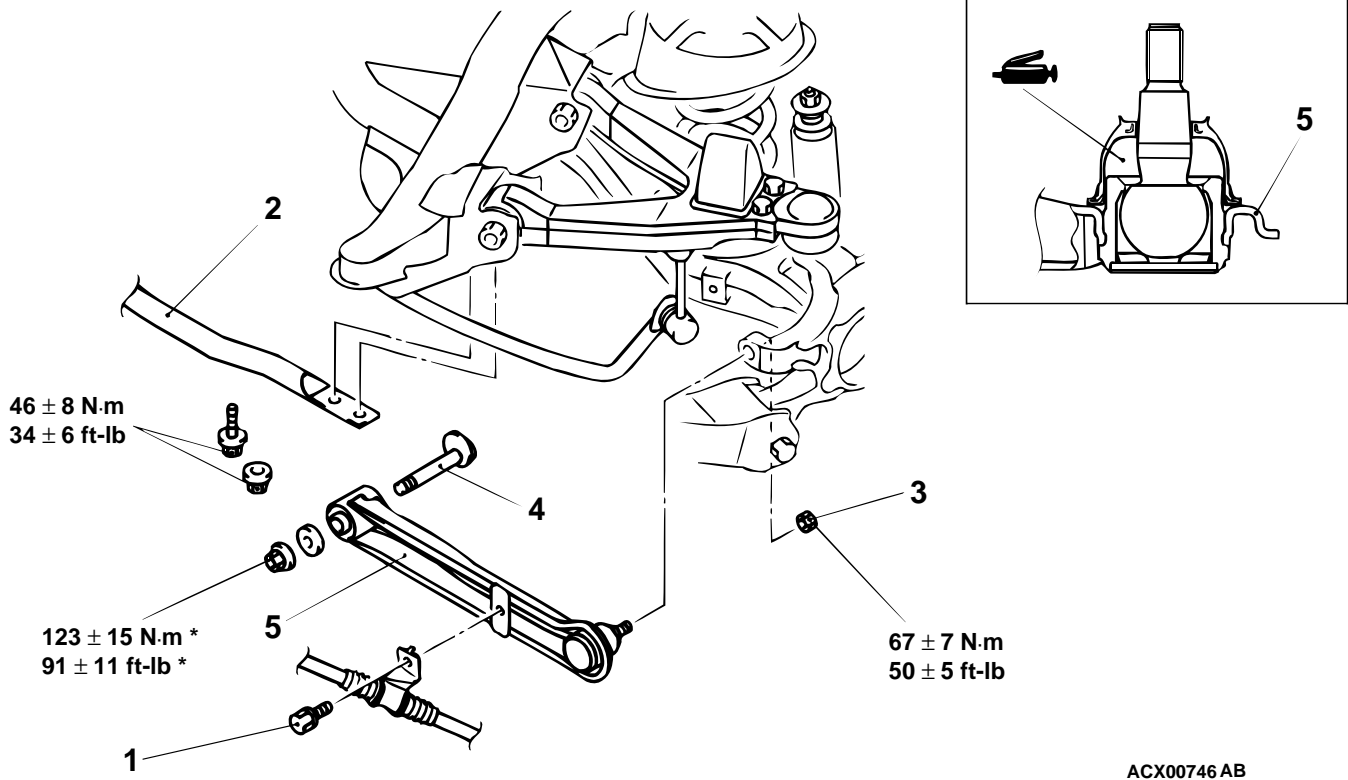

ACX00746 AB

**REMOVAL STEPS**

- <<A>>
1. PARKING BRAKE CABLE MOUNTING BOLT
  2. TOE CONTROL TOWER BAR
  3. TOE CONTROL ARM BALL JOINT AND KNUCKLE CONNECTION

**REMOVAL STEPS (Continued)**

- <<B>>
4. BOLT ASSEMBLY (FOR TOE ADJUSTING)
  5. TOE CONTROL ARM ASSEMBLY

**Required Special Tool:**

- MB991897: Ball Joint Remover

## REMOVAL SERVICE POINTS

### <<A>> TOE CONTROL ARM BALL JOINT AND KNUCKLE DISCONNECTION

#### **⚠ CAUTION**

- Do not remove the nut from ball joint. Loosen it and use special tool MB991897 to avoid possible damage to ball joint threads.
- Hang special tool MB991897 with a cord to prevent it from falling.

1. Install special tool MB991897 as shown in the figure.

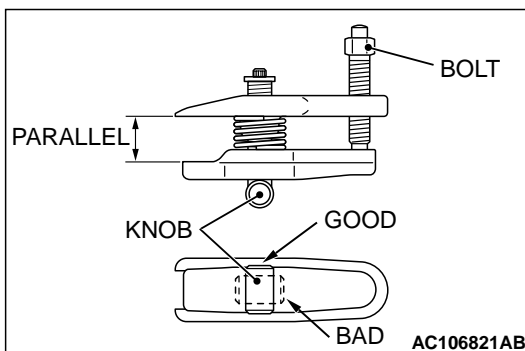
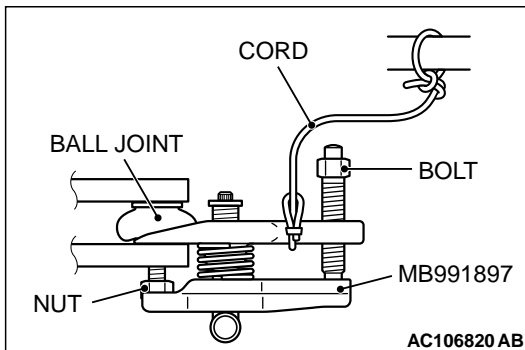

2. Turn the bolt and knob as necessary to make the jaws of special tool MB991897 parallel, tighten the bolt by hand and confirm that the jaws are still parallel.

*NOTE: When adjusting the jaws in parallel, make sure the knob is in the position shown in the figure.*

3. Tighten the bolt with a wrench to disconnect the ball joint.

### <<B>> BOLT ASSEMBLY (TOE ADJUSTING BOLT) REMOVAL

Make mating marks on the bracket and the toe adjusting bolt, and then remove the toe adjusting bolt.

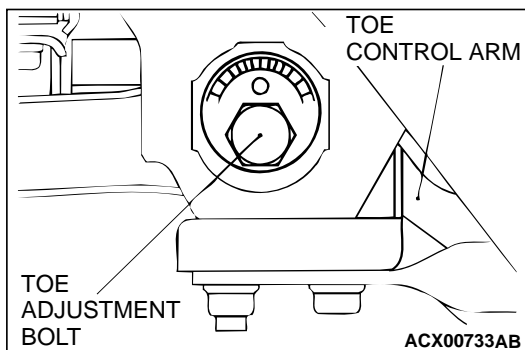

## INSPECTION

M1341015500090

- Check the bushing for wear and deterioration.
- Check the toe control arm for bending or breakage.
- Check all bolts for condition and straightness.

## TOE CONTROL ARM BALL JOINT TURNING TORQUE CHECK

### Required Special Tool:

- MB990326: Preload Socket

1. After shaking the ball joint stud several times, install the nut to the stud and use special tool MB990326 to measure the turning torque of the ball joint.

**Standard value: 0.7 – 1.0 N·m (6 – 9 in-lb)**

2. If the measured value exceeds the standard value, replace the toe control arm ball joint assembly.
3. If the measured value is lower than the standard value, check that the toe control arm ball joint turns smoothly without excessive play. If so, it is possible to use that ball joint.

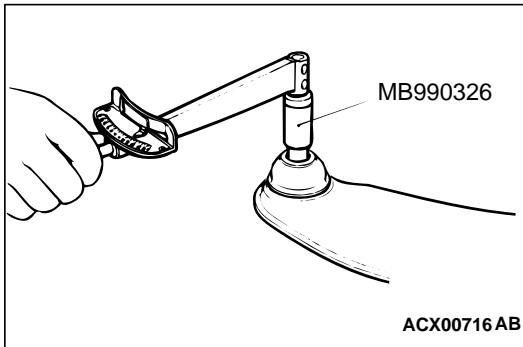

## TOE CONTROL ARM BALL JOINT DUST COVER CHECK

1. Press the dust cover with your finger to check that there are no cracks or damage in the dust cover.
2. If the dust cover is cracked or damaged, replace the toe control arm ball joint assembly.

*NOTE: If the dust cover is cracked or damaged, it is possible that there may also be damage to the ball joint. If it is damaged during service work, replace the dust cover.*

## TOE CONTROL ARM BALL JOINT DUST COVER REPLACEMENT

M1341014800139

### Required Special Tool:

- MB990800: Ball Joint Remover and Installer

If the dust cover is damaged accidentally during service work, replace the dust cover as follows:

1. Remove the clip ring, and then remove the dust cover.
2. Apply multipurpose grease to the inside of the dust cover as shown.
3. Apply multipurpose grease to the shown parts inside the dust cover and the ball joint stud.
4. Wrap plastic tape around the toe control arm ball joint stud, and then install the dust cover to the toe control arm ball joint.

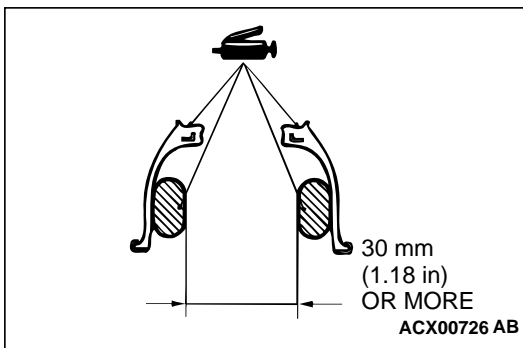

**CAUTION**

Do not apply grease to the place (tapered section) where the threaded section of the ball joint connects with the knuckle. Wipe the grease off if it is applied in this area. To prevent the grease from being applied to the ball joint connection (taper) with the knuckle, do not compress the dust cover before installation.

5. Using the special tool, drive the dust cover into the position shown in the illustration.
6. Press the dust cover with your finger to check that there are no cracks or damage in the dust cover.

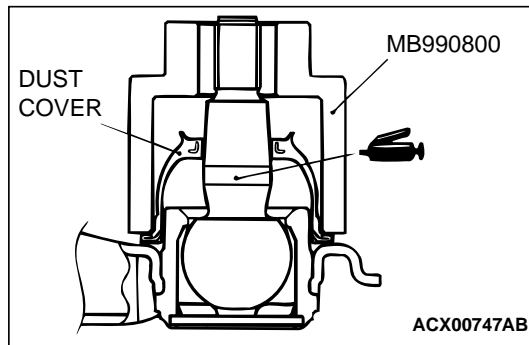

## TRAILING ARM ASSEMBLY

### REMOVAL AND INSTALLATION

M1341004200103

**CAUTION**

\*: Indicates parts which should be temporarily tightened, and then fully tightened with the vehicle on the ground in an unladen condition.

**Post-installation Operation**

- Wheel Alignment Check and Adjustment (Refer to P.34-6.)

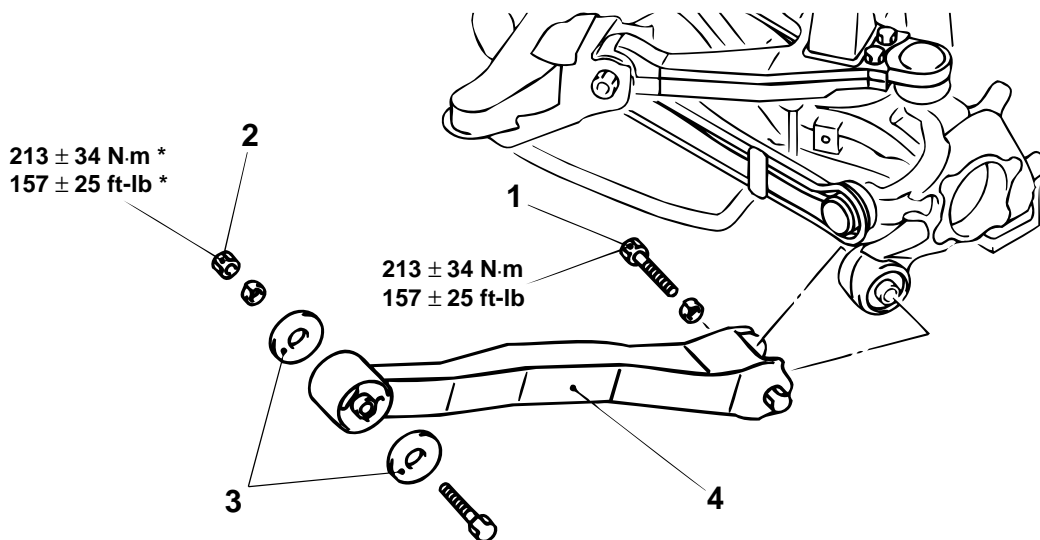

ACX00748 AC

**REMOVAL STEPS**

1. TRAILING ARM TO KNUCKLE SECURING BOLT
2. TRAILING ARM TO REAR FRAME SECURING NUT

**REMOVAL STEPS (Continued)**

3. STOPPER
4. TRAILING ARM

## TRAILING ARM BUSHING REPLACEMENT

M1341011300113

## Required Special Tool:

- MD998236: Output Shaft Bearing Installer

1. Use special tool MD998236 to drive in/out the bushing from/to the trailing arm.

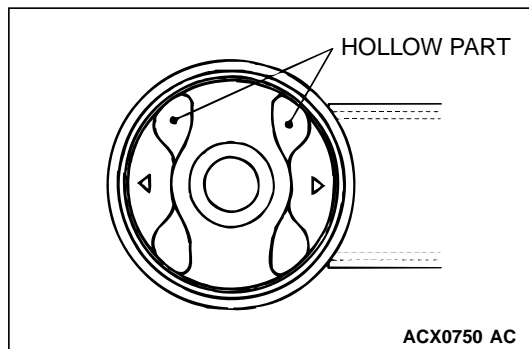
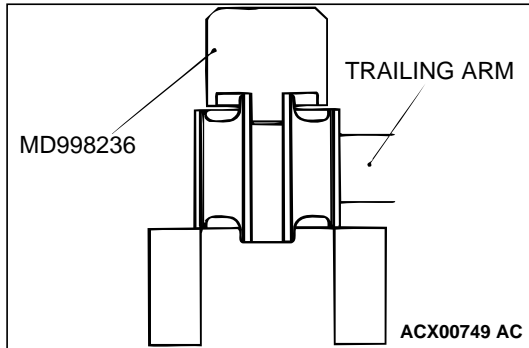

2. When assembling, apply soapy water around the bushing and the inner diameter of the trailing arm, and then drive in the bushing so that it protrudes by the same amount at either side and its hollow part is as shown.

## SPECIFICATIONS

## FASTENER TIGHTENING SPECIFICATIONS

M1341012700233

ITEM	SPECIFICATION
<b>Rear suspension assembly</b>	
Brake tube flare nut	15 ± 2 N·m (11 ± 2 ft-lb)
Crossmember mounting nut	167 ± 19 N·m (123 ± 14 ft-lb)
Nut securing lower arm to knuckle assembly	152 ± 25 N·m (113 ± 18 ft-lb)
Nut securing lower arm to body	123 ± 15 N·m (91 ± 11 ft-lb)
Nut securing shock absorber to lower arm assembly	152 ± 25 N·m (113 ± 18 ft-lb)
Nut securing trailing arm to rear frame	213 ± 34 N·m (157 ± 25 ft-lb)
Propeller shaft assembly nut	60 ± 10 N·m (45 ± 7 ft-lb)
Rear disc brake assembly mounting bolt	88 ± 10 N·m (65 ± 7 ft-lb)
<b>Upper arm assembly</b>	
Brake pipe connection	15 ± 2 N·m (11 ± 2 ft-lb)
Nut securing upper arm assembly to rear frame	167 ± 10 N·m (124 ± 7 ft-lb)
Nut securing upper arm ball joint to knuckle	150 ± 30 N·m (111 ± 22 ft-lb)
Nut securing upper arm to upper arm ball joint assembly	98 ± 12 N·m (72 ± 9 ft-lb)
Stabilizer link mounting nut	104 ± 14 N·m (77 ± 10 ft-lb)



ITEM	SPECIFICATION
<b>Shock absorber, coil spring and lower arm assembly</b>	
Nut securing lower arm to knuckle assembly	152 ± 25 N·m (113 ± 18 ft-lb)
Nut securing lower arm to body	123 ± 15 N·m (91 ± 11 ft-lb)
Nut securing shock absorber to lower arm assembly	152 ± 25 N·m (113 ± 18 ft-lb)
Shock absorber connecting nut	44 ± 10 N·m (33 ± 7 ft-lb)
<b>Stabilizer bar</b>	
Stabilizer clamp mounting bolt	44 ± 10 N·m (33 ± 7 ft-lb)
<b>Toe control arm assembly, toe control tower bar</b>	
Nut securing toe control arm ball joint to knuckle	67 ± 7 N·m (50 ± 5 ft-lb)
Nut securing toe control arm to rear frame	123 ± 15 N·m (91 ± 11 ft-lb)
Toe control tower bar mounting bolt, nut	46 ± 8 N·m (34 ± 6 ft-lb)
<b>Trailing arm assembly</b>	
Nut securing trailing arm to knuckle	213 ± 34 N·m (157 ± 25 ft-lb)
Nut securing trailing arm to rear frame	213 ± 34 N·m (157 ± 25 ft-lb)

**GENERAL SPECIFICATIONS**

M1341000200231

**COIL SPRING**

ITEM	SPECIFICATION
Wire diameter mm (in)	17 – 19 (0.67 – 0.75)
Average diameter mm (in)	132 – 134 (5.20 – 5.28)
Free length mm (in)	343 (13.5)

**SERVICE SPECIFICATIONS**

M1341000300272

ITEM	SPECIFICATION
Toe-in mm (in)	3 ± 3 (0.12 ± 0.12)
Camber	0°00' ± 30' (Left/right deviation within 30')
Upper arm ball joint turning torque N·m (in-lb)	1.5 – 7.9 (13 – 70)
Stabilizer link ball joint turning torque N·m (in-lb)	0.5 – 2.0 (4 – 17)
Toe control arm ball joint turning torque N·m (in-lb)	0.7 – 1.0 (6 – 9)

---

## NOTES