GENERAL

Click on the applicable bookmark to selected the required model year.

GENERAL

CONTENTS

HOW TO USE THIS MANUAL	2	VEHICLE IDENTIFICATION	16
Scope of Maintenance, Repair and Servicing		Vehicle Information Code Plate	16
Explanations	2	Models	16
Definition of Terms	2	Model Code	18
Indication of Tightening Torque	2	Chassis Number	19
Model Indications	3	Engine Model Number	20
Explanation of Manual Contents	4	Theft Protection <For R.H.D.>	21
HOW TO USE TROUBLESHOOTING/INSPECTION SERVICE POINTS	6	MAJOR SPECIFICATIONS	23
Troubleshooting Contents	6	PRECAUTIONS BEFORE SERVICE	29
Diagnosis Function	7	SUPPLEMENTAL RESTRAINT SYSTEM (SRS)	33
How to Use the Inspection Procedures	10	SUPPORT LOCATIONS FOR LIFTING AND JACKING	37
Connector Measurement Service Points	11	Support Positions for a Garage Jack	37
Connector Inspection	12	Support Positions for axle stands and a Single-Post Lift or Double-Post Lift	38
Inspection Service Points for a Blown Fuse ...	13	STANDARD PARTS-TIGHTENING-TORQUE TABLE	39
Points to Note for Intermittent Malfunctions ...	13		
TREATMENT BEFORE/AFTER THE FORDING A STREAM	14		
Inspection and Service before Fording a Stream	14		
Inspection and Service after Fording a Stream	15		

HOW TO USE THIS MANUAL

SCOPE OF MAINTENANCE, REPAIR AND SERVICING EXPLANATIONS

This manual provides explanations, etc. concerning procedures for the inspection, maintenance, repair and servicing of the subject model. Note, however, that for engine and transmission-related component parts, this manual covers only on-vehicle inspections, adjustments, and the removal and installation procedures for major components.

For detailed information concerning the inspection, checking, adjustment, disassembly and reassembly of the engine, transmission and major components after they have been removed from the vehicle, please refer to separate manuals covering the engine and the transmission.

ON-VEHICLE SERVICE

“On-vehicle Service” is procedures for performing inspections and adjustments of particularly important locations with regard to the construction and for maintenance and servicing, but other inspection (for looseness, play, cracking, damage, etc.) must also be performed.

INSPECTION

Under this title are presented inspection and checking procedures to be performed by using special tools and measuring instruments and by feeling, but, for actual maintenance and servicing procedures, visual inspections should always be performed as well.

DEFINITION OF TERMS

STANDARD VALUE

Indicates the value used as the standard for judging the quality of a part or assembly on inspection or the value to which the part or assembly is corrected and adjusted. It is given by tolerance.

LIMIT

Shows the standard for judging the quality of a part or assembly on inspection and means the maximum or minimum value within which the part or assembly must be kept functionally or in strength. It is a value established outside the range of standard value.

REFERENCE VALUE

Indicates the adjustment value prior to starting the work (presented in order to facilitate assembly and adjustment procedures, and so they can be completed in a shorter time).

CAUTION

Indicates the presentation of information particularly vital to the worker during the performance of maintenance and servicing procedures in order to avoid the possibility of injury to the worker, or damage to component parts, or a reduction of component or vehicle function or performance, etc.

INDICATION OF TIGHTENING TORQUE

Tightening torques (units: N·m) are set to take into account the central value and the allowable tolerance. The central value is the target value, and the allowable tolerance provides the checking range for tightening torques. If bolts and nuts are not provided with tightening torques, refer to P.00-39.

MODEL INDICATIONS

The following abbreviations are used in this manual for classification of model types.

GDI: Indicates the gasoline direct injection.

DOHC: Indicates an engine with the double overhead camshaft, or models equipped with such an engine.

M/T: Indicates the manual transmission, or models equipped with the manual transmission.

A/T: Indicates the automatic transmission, or models equipped with the automatic transmission.

A/C: Indicates the air conditioner.

EXPLANATION OF MANUAL CONTENTS

Indicates procedures to be performed before the work in that section is started, and procedures to be performed after the work in that section is finished.

Component Diagram

A diagram of the component parts is provided near the front of each section in order to give a reader a better understanding of the installed condition of component parts.

Indicates (by symbols) where lubrication is necessary.

Maintenance and Servicing Procedures

The numbers provided within the diagram indicate the sequence for maintenance and servicing procedures.

- Removal steps:
The part designation number corresponds to the number in the illustration to indicate removal steps.
- Disassembly steps:
The part designation number corresponds to the number in the illustration to indicate disassembly steps.

- Installation steps:
Specified in case installation is impossible in reverse order of removal steps. Omitted if installation is possible in reverse order of removal steps.
- Reassembly steps:
Specified in case reassembly is impossible in reverse order of disassembly steps. Omitted if reassembly is possible in reverse order of disassembly steps.

Classifications of Major Maintenance/Service Points

When there are major points relative to maintenance and servicing procedures (such as essential maintenance and service points, maintenance and service standard values, information regarding the use of special tools, etc.), these are arranged together as major maintenance and service points and explained in detail.

- ◀A▶ : Indicates that there are essential points for removal or disassembly.
▶A◀ : Indicates that there are essential points for installation or reassembly.

Symbols for Lubrication, Sealants and Adhesives

Information concerning the locations for lubrication and for application of sealants and adhesives is provided, by using symbols, in the diagram of component parts or on the page following the component parts page, and explained.



: Grease
(multipurpose grease unless there is a brand or type specified)



: Sealant or adhesive



: Brake fluid or automatic transmission fluid



: Engine oil, gear oil or air conditioner compressor oil



: Adhesive tape or butyl rubber tape

Indicates the group title.

Indicates the section title.

Indicates the group number.

Indicates the page number.

STEERING - Power Steering Oil Pump 37A-29

POWER STEERING GEAR BOX

12000039

REMOVAL AND INSTALLATION

Pre-removal Operation

- (1) Power Steering Fluid Draining (Refer to P. 37A-10.)
- (2) Air Cleaner Assembly Removal
- (3) Under Cover Removal (Refer to GROUP 42 - Under Cover.)

<2WD>

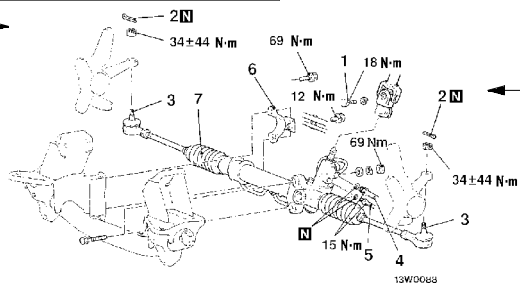

N denotes non-re-usable part.

Denotes tightening torque. For bolts and nuts which do not have a tightening torque listed, refer to the "Standard Parts-tightening-torque Table".

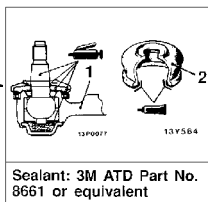

Sealant: 3M ATD Part No. 8661 or equivalent

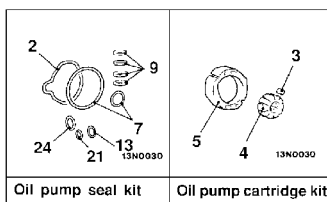

Repair kit or set parts are shown. (Only very frequently used parts are shown.)

Removal steps

1. Lower shaft assembly and gear box connecting bolt
2. Split pin
3. Connection for tie-rod end and knuckle
4. Connection for return tube

5. Connection for pressure tube
6. Clamp
7. Gear box assembly

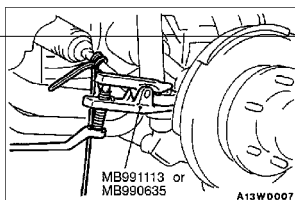

REMOVAL SERVICE POINTS

▲ TIE-ROD END DISCONNECTION

Caution

1. Using the special tool, loosen the tie rod end mounting nut. Only loosen the nut; do not remove it from the ball joint.
2. Support the special tool with a cord, etc. to prevent it from coming off.

Operating procedures, cautions, etc. on removal, installation, disassembly and reassembly are described.

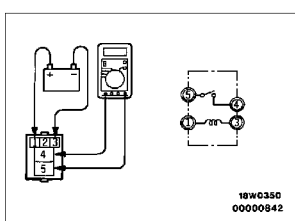

HEADLAMP RELAY CONTINUITY INSPECTION

Battery voltage	Terminal No.			
	1	3	4	5
Power is not supplied	○	○	○	○
Power is supplied	⊕	- ⊖	○	○

○—○ indicates that there is a continuity between the terminals.
 ⊕—⊖ indicates terminals to which battery voltage is applied.

35A-26 BASIC BRAKE SYSTEM - Master Cylinder and Brake Booster

Lubrication and sealing points

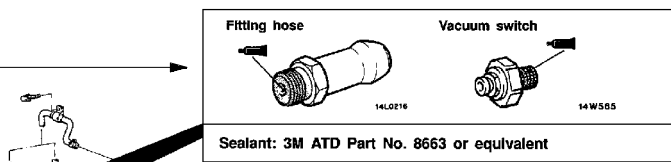

The title of the page (following the page on which the diagram of component parts is presented) indicating the locations of lubrication and sealing procedures.

HOW TO USE TROUBLESHOOTING/INSPECTION SERVICE POINTS

Troubleshooting of electronic control systems for which the MUT-II can be used follows the basic outline described below. Furthermore, even in systems for which the MUT-II cannot be used, part of these systems still follow this outline.

TROUBLESHOOTING CONTENTS

1. STANDARD FLOW OF DIAGNOSIS TROUBLESHOOTING

The troubleshooting sections follow the basic diagnosis flow which is given below. If the diagnosis flow is different from that given below, or if additional explanation is required, the details of such differences or additions will also be listed.

Diagnosis method

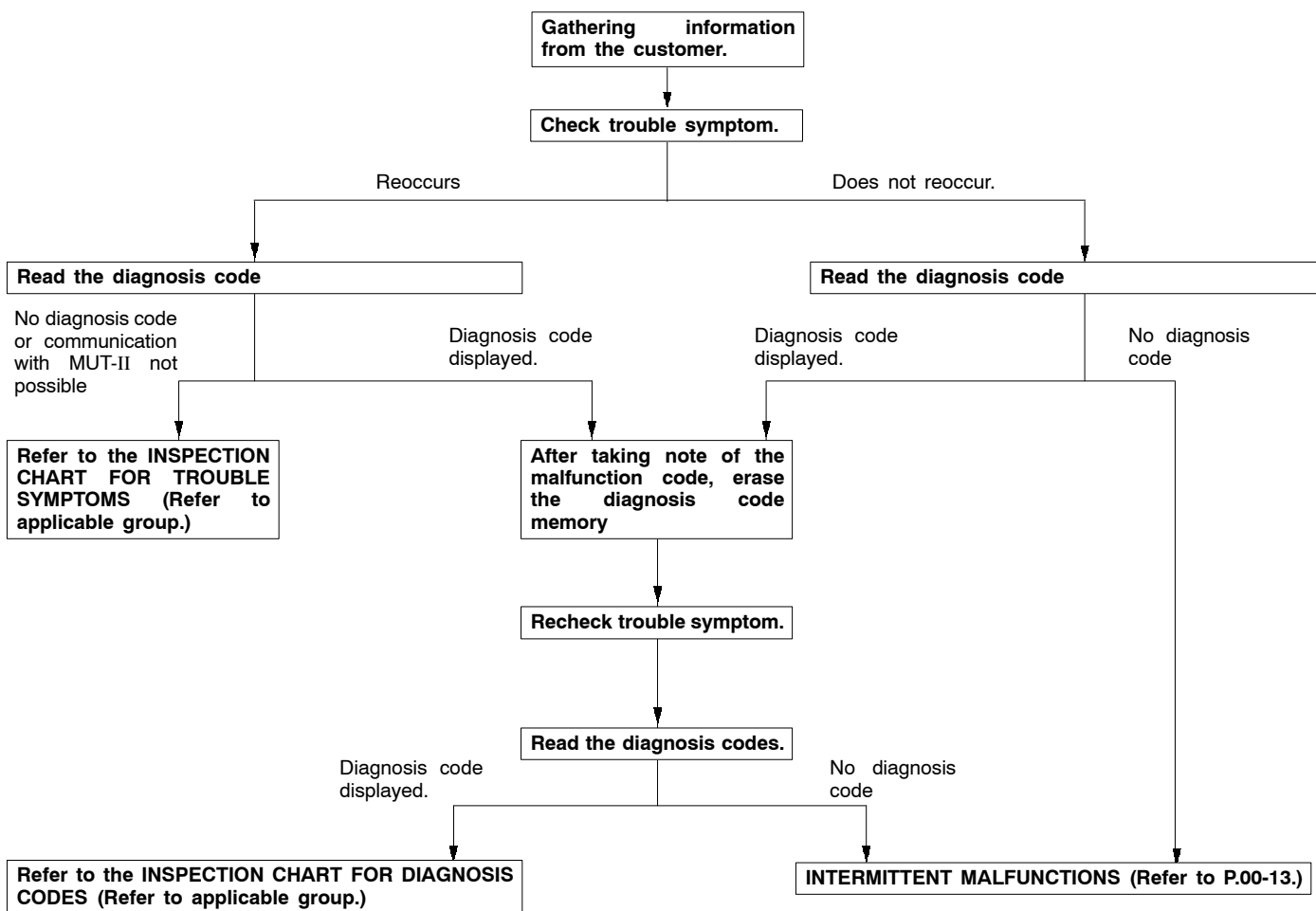

2. SYSTEM OPERATION AND SYMPTOM VERIFICATION TESTS

If verification of the trouble symptoms is difficult, procedures for checking operation and verifying trouble symptoms are shown.

3. DIAGNOSIS FUNCTION

Details which are different from those in the “Diagnosis Function” section on the next page are listed.

4. INSPECTION CHART FOR DIAGNOSIS CODES**5. INSPECTION PROCEDURE FOR DIAGNOSIS CODES**

Indicates the inspection procedures corresponding to each diagnosis code. (Refer to P.00-10 for how to use the inspection procedures.)

6. INSPECTION CHART FOR TROUBLE SYMPTOMS

If there are trouble symptoms even though the results of inspection using the MUT-II show that all diagnosis codes are normal, inspection procedures for each trouble symptom will be found by means of this chart.

7. INSPECTION PROCEDURE FOR TROUBLE SYMPTOM

Indicates the inspection procedures corresponding to each trouble symptoms classified in the Inspection Chart for Trouble Symptoms. (Refer to P.00-10 for how to use the inspection procedures.)

8. SERVICE DATA REFERENCE TABLE

Inspection items and normal judgement values have been provided in this chart as reference information.

9. CHECK AT ECU TERMINALS

Terminal numbers for the ECU connectors, inspection items and standard values have been provided in this chart as reference information.

10. INSPECTION PROCEDURES USING AN OSCILLOSCOPE

When there are inspection procedures using an oscilloscope, these are listed here.

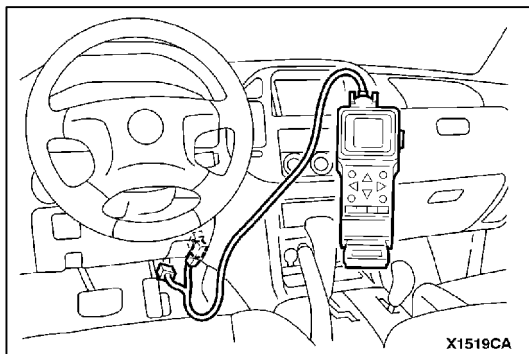
**DIAGNOSIS FUNCTION****METHOD OF READING DIAGNOSIS CODES****WHEN USING THE MUT-II**

Connect the MUT-II to the diagnosis connector and take a reading of the diagnosis codes.

Caution

Turn the ignition switch to “LOCK(OFF)” position before connecting or disconnecting the MUT-II.

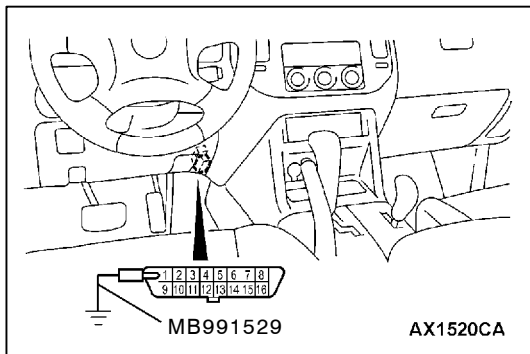

WHEN USING THE WARNING LAMP

1. Use the special tool to earth No.1 terminal (diagnosis control terminal) of the diagnosis connector.
2. Turn on the ignition switch.
3. Read out a diagnosis code by observing how the warning lamp flashes.

Applicable systems

System name	Warning lamp name
A/T	Neutral position indicator lamp
ABS	ABS warning lamp
SS4 II	4WD warning lamp
Hydraulic Brake Booster(HBB)	Brake warning lamp

Indication of diagnosis code by warning lamp

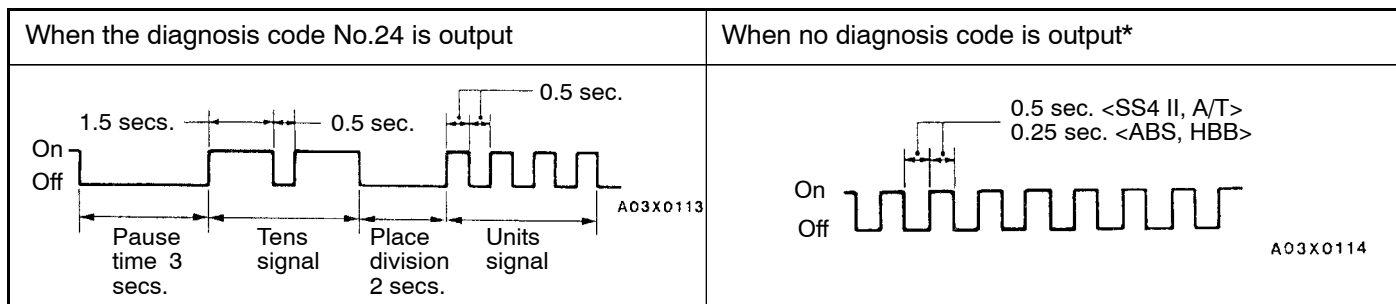

NOTE

*: Even if the ABS system is normal, removing the valve relay causes the diagnosis code No.52 to be output.

METHOD OF ERASING DIAGNOSIS CODES

WHEN USING THE MUT-II

Connect the MUT-II to the diagnosis connector and erase the diagnosis code.

Caution

Turn the ignition switch to “LOCK (OFF)” position before connecting or disconnecting the MUT-II.

WHEN NOT USING THE MUT-II

1. Turn the ignition switch to “LOCK(OFF)” position.
2. After disconnecting the battery cable from the battery (-) terminal for 10 seconds or more, reconnect the cable.
3. After the engine has warmed up, run it at idle for about 15 minutes.

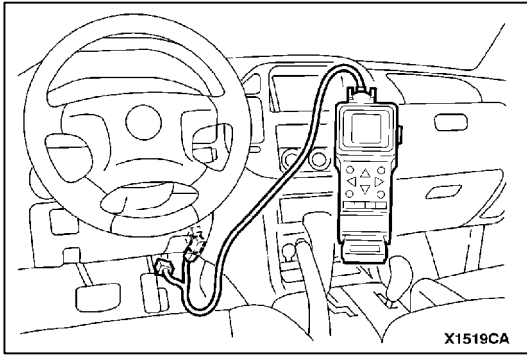
**INPUT SIGNAL CHECK <SWS>****WHEN USING THE MUT-II**

- (1) Connect the MUT-II to the diagnosis connector and erase the diagnosis code.

Caution

Turn the ignition switch to “LOCK (OFF)” position before connecting or disconnecting the MUT-II.

- (2) If the MUT-II buzzer sounds once when each switch is operated (ON/OFF), the input signal for that switch circuit system is normal.

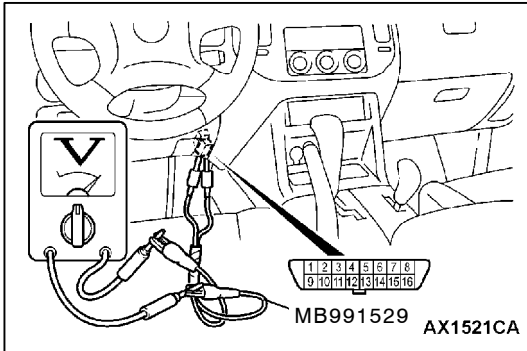
**WHEN USING A VOLTMETER**

- (1) Use the special tool to connect the ETACS terminal (terminal 9) and the earth terminals (terminals 4 and 5) of the diagnosis connector to the voltage meter.
- (2) If the needle of the voltage meter flickers once when each switch is operated (ON/OFF), the input signal for that switch circuit system is normal.