

E91212

**SAMPLE**

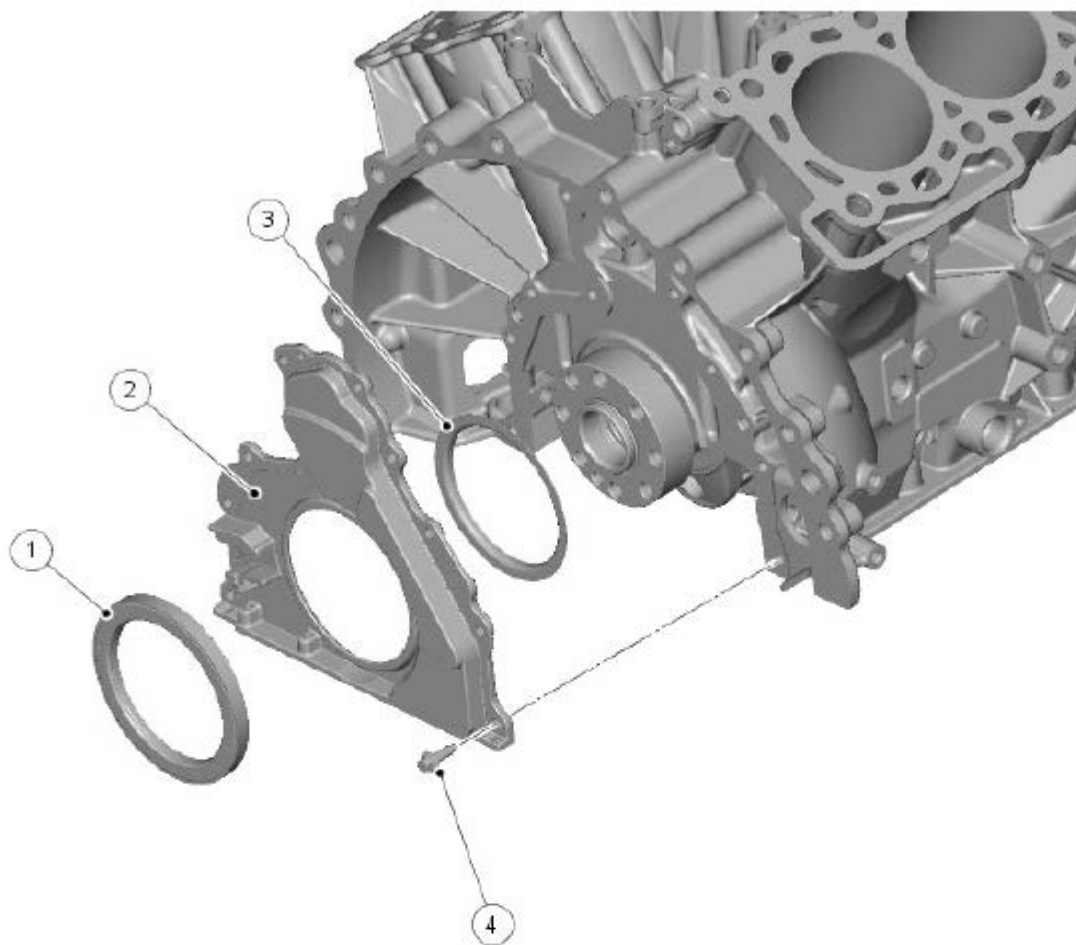

E152122

Item	Part Number	Description
1	-	Reluctor ring
2	-	Rear oil seal retainer
3	-	Seal
4	-	Bolt (10 off)

The rear main oil seal and retainer assembly is a one-piece unit and is supplied with its own fitting sleeve. The seal and retainer have 2 locating dowels, 10 fixing bolts and a seal. In addition, the retainer has a location for the CKP (Crankshaft Position) sensor.

For additional information, refer to: [Electronic Engine Controls](#) (303-14A Electronic Engine Controls - TDV6 3.0L Diesel, Description and Operation).

CRANKSHAFT RELUCTOR RING

# SAMPLE



**CLEAN ENGINE BREATHER FILTER - V8**

1. Release hose clamp and pull hose off canister.
2. Unscrew canister and remove it from rocker cover.
3. Remove large 'O' ring from threaded end of canister.
4. Visually inspect condition of wire screen within canister, if in poor condition fit new assembly, if in acceptable condition clean screen as follows:
5. Immerse canister in small amount of solvent and allow solvent to dissolve and loosen any debris.
6. Remove canister from solvent and dry in still air.

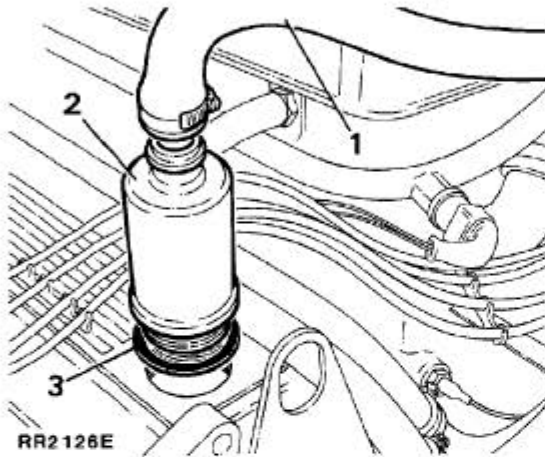

RR2126E



**WARNING:** Do not use compressed air line to remove remaining solvent or debris in canister, this could cause fire or personal injury.

**Refitting breather/filter**

1. Fit new rubber 'O' ring.
2. Screw canister into rocker cover, hand tight only.
3. Refit hose, tighten clamp securely.

**CLEAN PLENUM CHAMBER VENTILATION PASSAGEWAY - V8**

Cleaning plenum chamber ventilation passageway can be carried out without removing plenum chamber from ram housing.



**CAUTION:** Care must be taken to prevent debris from passageway passing beyond throttle butterfly disc.



**WARNING:** Safety glasses must be worn when performing this operation. Ensure that debris is not blown into atmosphere which could be harmful to other persons closeby.

1. Disconnect battery negative lead.
2. Release hose clamp and remove hose from plenum chamber inlet.
3. Remove crankcase ventilation hose from side of plenum chamber.
4. Insert a piece of lint free cloth down throttle butterfly bore to prevent debris passing throttle butterfly.
5. Place a cloth over tube protruding from side of plenum from which ventilation hose was removed to prevent debris from passageway being blown into atmosphere.

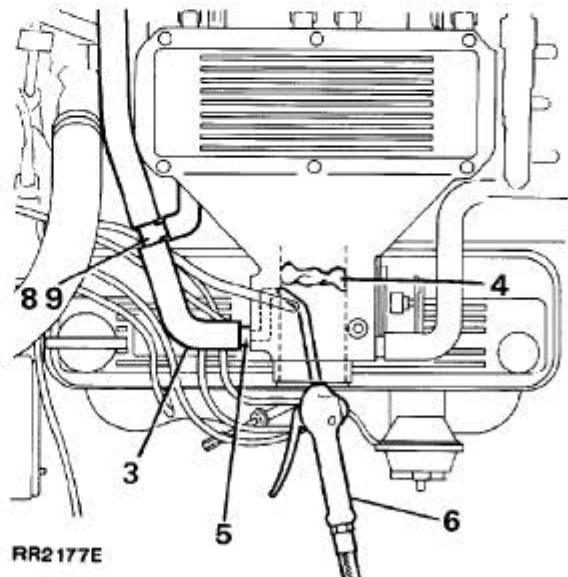

RR2177E

**SAMPLE**



**RANGE ROVER SPORT**  
Hybrid Electric Vehicle

(From January 2014)

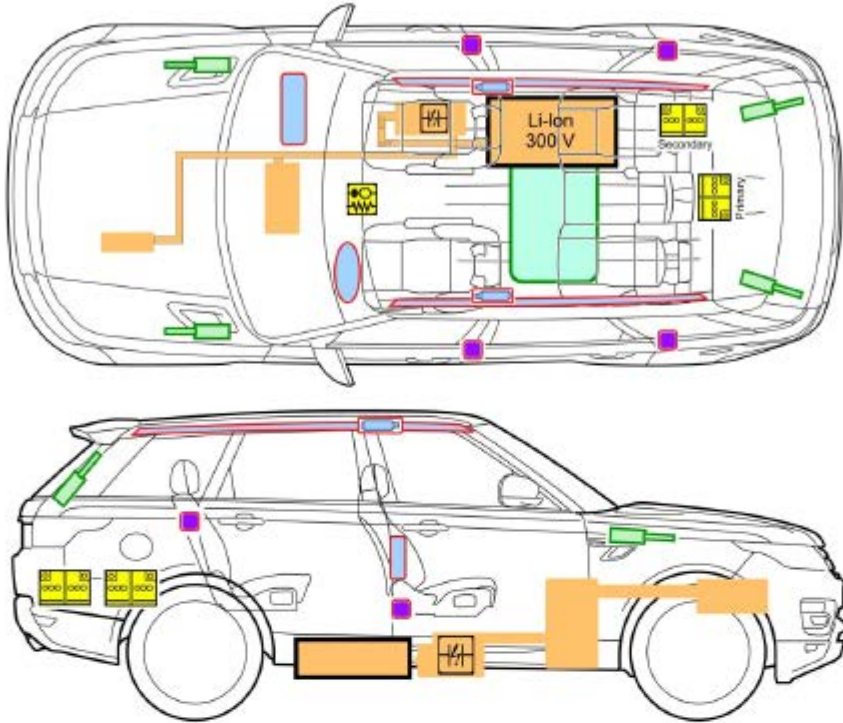

E158378

**Legend:**

	<b>Airbag</b>		<b>Stored gas inflator</b>		<b>Seatbelt pretensioner</b>		<b>Gas strut</b>
	<b>Battery low voltage</b>		<b>SRS control unit</b>		<b>Fuel tank</b>		<b>High voltage power cable/component</b>
	<b>High voltage battery pack</b>		<b>High voltage capacitor</b>				

E158379

The legend shows the maximum possible vehicle equipment.

	<b>Danger to life!</b> Do not touch high voltage components
--	--

Brand	Model	Body shape	Starting year	Year of introduction	Created	Version date	ID No	Version No	Page No
Range Rover Sport	L494	SUV	2013	2013	21/12/12	13/08/13	HEV RS 1	V6	1/4

**SAMPLE**

Torque: 10 Nm

5.

**CAUTION:**

Make sure all mating faces are clean and dry before applying sealant.

**NOTE:**

Apply sealant WSE-M4G323-A6 in a 2-3mm diameter on the engine block as shown. The component must be installed and tightened within 10 minutes of sealant application.

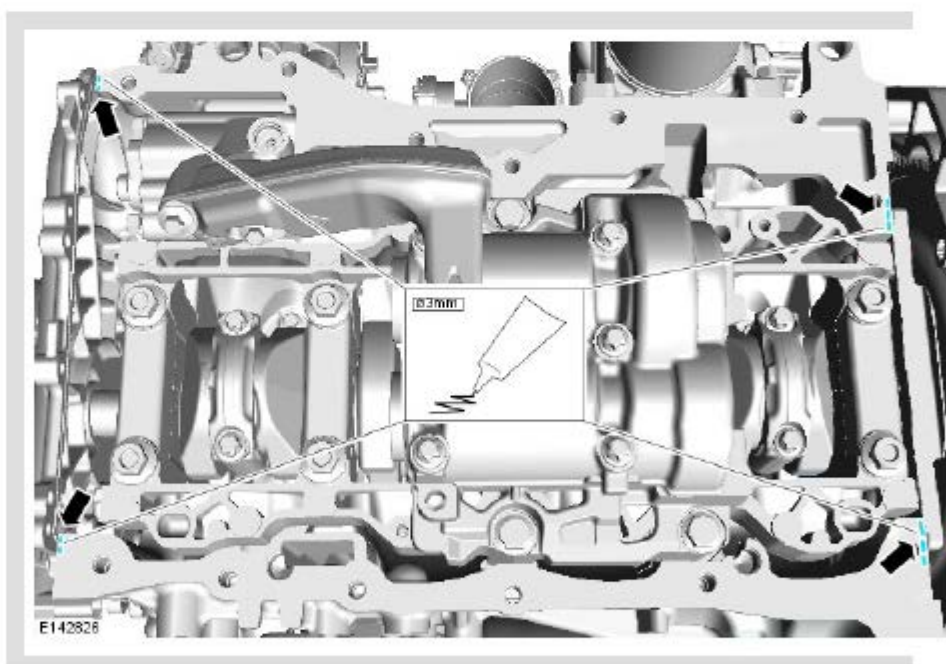

6.

**CAUTION:**

Make sure all mating faces are clean and dry before applying sealant.

**SAMPLE**

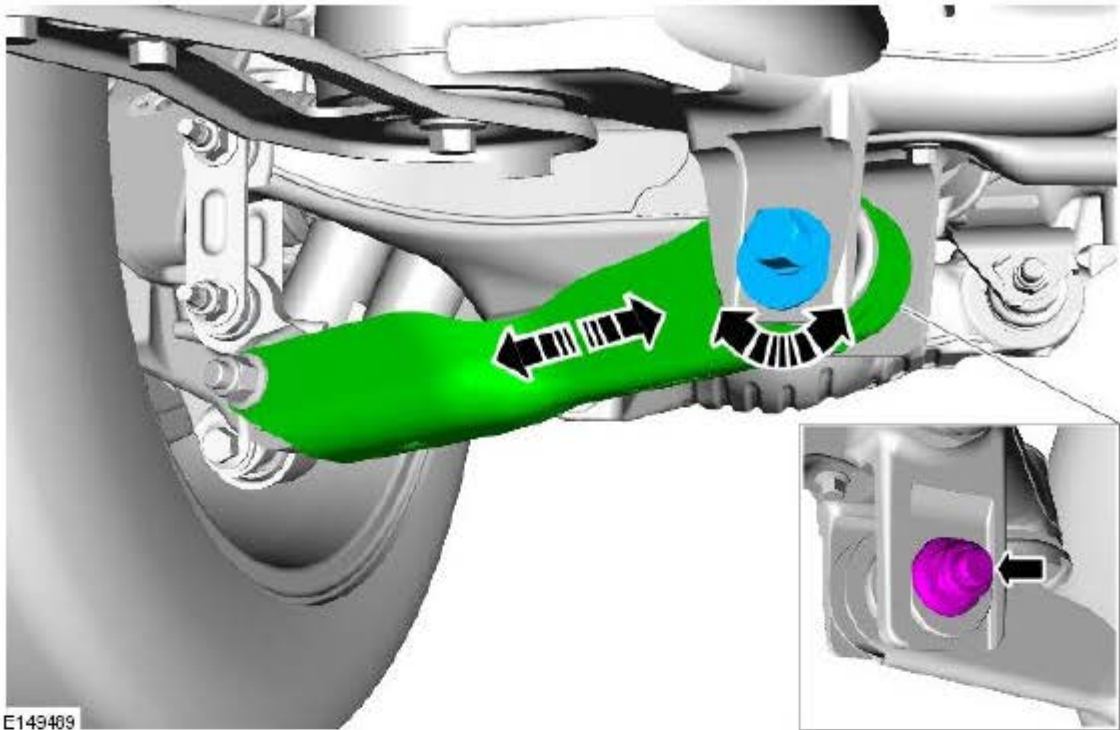

### Front Alignment

 **NOTE:** Make sure that the front camber is set within the correct tolerance before checking or adjusting the front toe alignment.

#### 1. NOTES:



To adjust the front camber the upper wishbone arms must be replaced.



Changing the upper wishbone arm will generate a  $\pm 0.5^\circ$  change in front camber depending on the component installed.

If necessary adjust the front wheel camber. Note the readings from the steering geometry test equipment and adjust the geometry as required.

For additional information, refer to: Upper Arm LH (204-01, Removal and Installation) / Upper Arm RH (204-01, Removal and Installation).

2. Roll the vehicle backwards and forwards to settle the steering and suspension.

3. Set the vehicle into tight tolerance mode.

For additional information, refer to: Air Suspension Manual Tight Tolerance Setting Mode (204-05, General Procedures).



**CAUTION:** To prevent damage to the tie rods, use an additional wrench when loosening or tightening the components.

Loosen the tie-rod end lock nut.

# SAMPLE

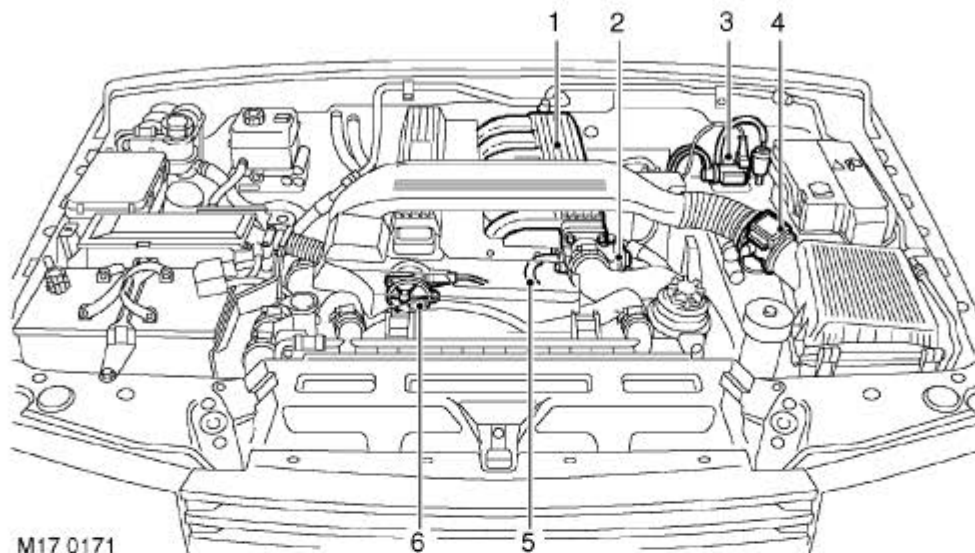
**Exhaust Gas Recirculation (EGR)**

M17 0171

**Component location**

1. Intake Manifold
2. EGR Valve
3. EGR Modulator Valve
4. Mass Air Flow (MAF) Sensor
5. Pipe - Exhaust Manifold to EGR Valve
6. Vacuum Pump - EGR System

During certain running conditions, the EGR system directs exhaust gases into the intake manifold to be used in the combustion process. The principal affect of this is to reduce combustion temperatures by reducing the amount of oxygen fed into the combustion chamber, which in turn reduces Oxides of Nitrogen (NO<sub>x</sub>) emissions. Up to 50% of the intake air can be replaced by exhaust gas.

Recirculating too much exhaust gas can result in higher emissions of soot, HC and CO due to insufficient air. The precise quantity of recirculated gas is controlled by the ECM to ensure that optimum conditions are maintained.

The ECM controls an EGR modulator valve mounted on the LH inner wing. This valve, when modulated, opens an EGR valve on the inlet manifold and directs exhaust gases into the inlet manifold. The EGR modulator valve controls the supply of vacuum from a vacuum pump located at the front of the cylinder head.

Exhaust gases are fed from a metal pipe on the exhaust manifold to the EGR valve on the inlet manifold. The pipe is secured at each end by a flanged connection secured by two bolts.

In operation, the ECM monitors engine conditions and signals the EGR modulator to supply a vacuum to the EGR valve.

# SAMPLE



## REMOVAL AND INSTALLATION

76.13.29	TRIM PANEL - B-PILLAR - LOWER - RENEW	ALL DERIVATIVES	0.1	USED WITHINS
----------	---	--------------------	-----	-----------------

## REMOVAL

1.

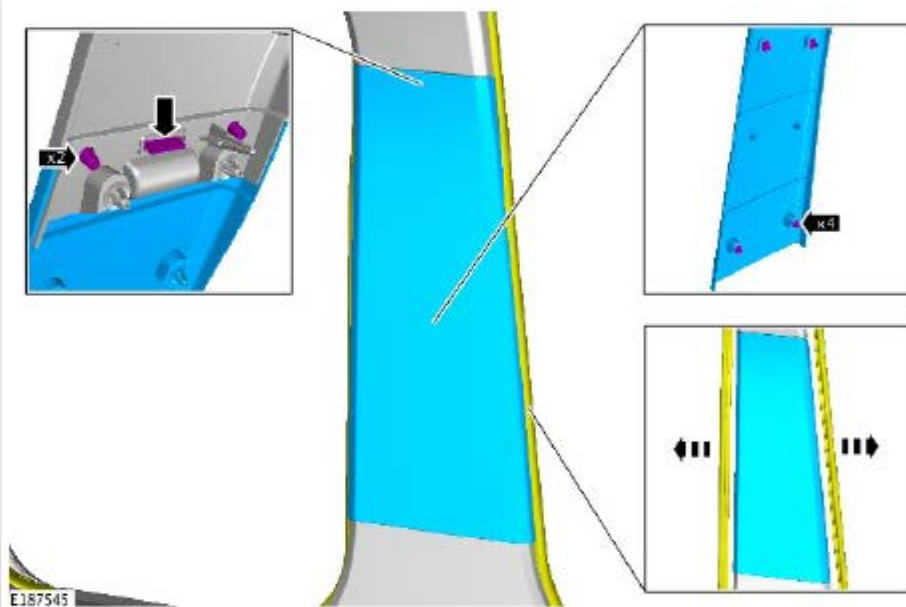

Remove the B-pillar lower trim panel.

Release weatherstrip from both sides of the B-pillar lower trim panel.

Release the 4 clips.

Remove and discard the 4 clips.

## INSTALLATION

1.

To install, reverse the removal procedure.

Install 4 new clips to the B-pillar lower trim panel.

**SAMPLE**

## SPECIFICATIONS

### COMPONENT OVERVIEW

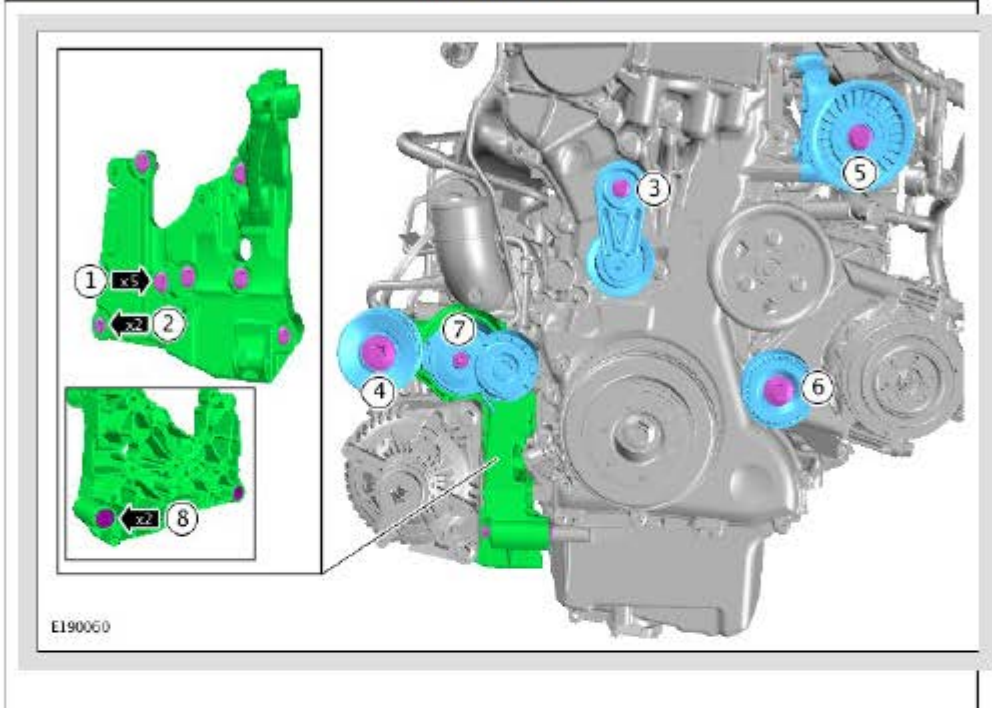

### Torque Specifications

DESCRIPTION	NM	LB-FT
Front safety belt lower anchorage to seat Torx bolt	40	30
C-pillar lower trim panel Torx screw	8	6
C-pillar upper trim panel Torx screw	6	4
* A-pillar trim panel Torx screw	3	2
* Rear safety belt lower anchorage Torx bolt	45	33
Foot rest trim panel bolt	5	4
Rear seat assembly retaining Torx bolts	40	30
Engine cover retaining nuts - supercharged vehicles	5	4
Loadspace anchor point retaining bolts	25	18

\* New bolt must be installed

# SAMPLE

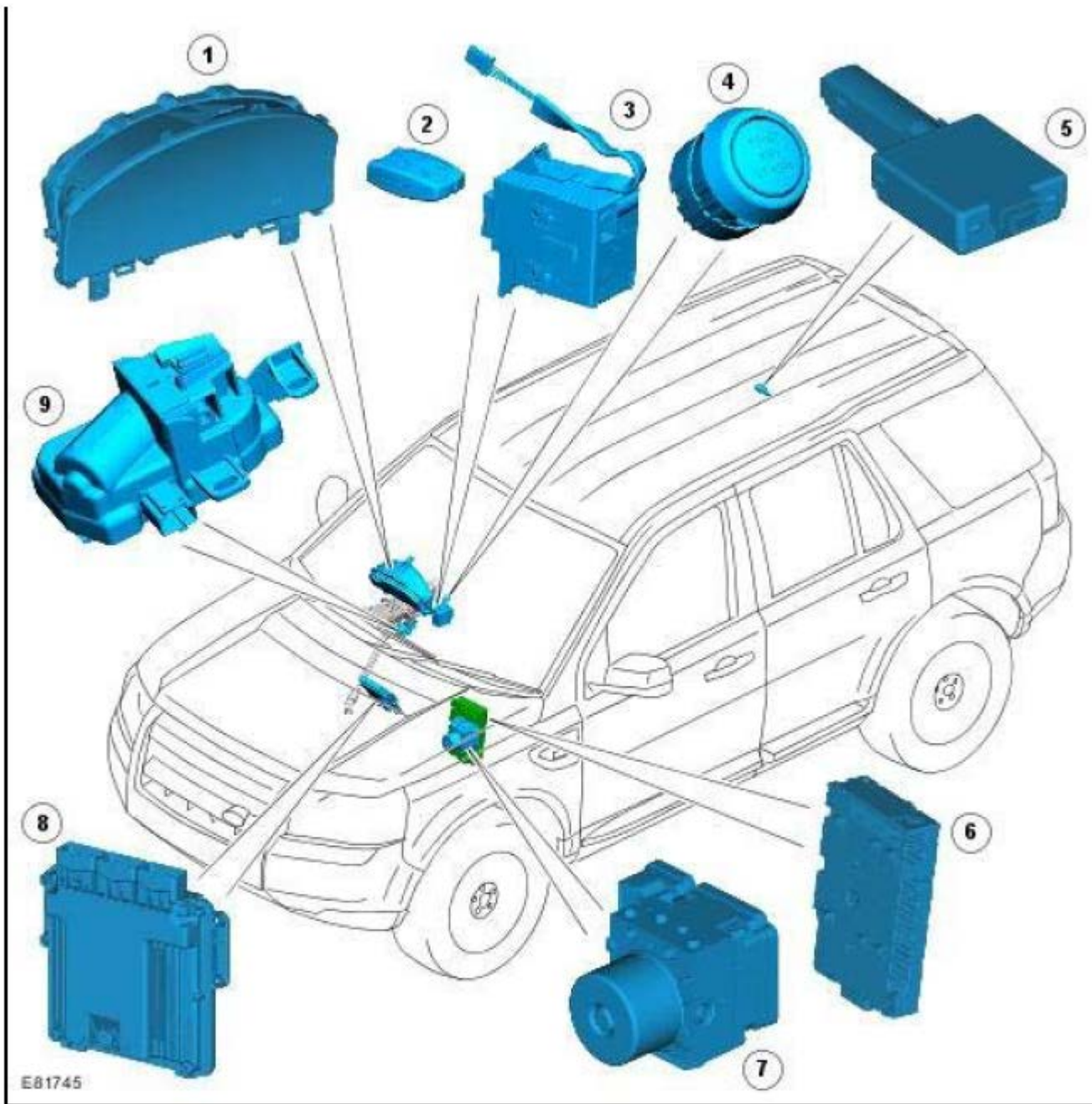

Item Number	Description
1	Instrument cluster
2	Remote handset
3	Start control module
4	Stop/Start switch

**SAMPLE**

## REMOVAL

1. Refer to: [Rear End Accessory Drive \(303-05A Accessory Drive - TDV6 3.0L Diesel, Removal and Installation\)](#).
2. Refer to: [Air Conditioning System Recovery, Evacuation and Charging \(412-00 Climate Control System - General Information, General Procedures\)](#).

3.

### NOTE:

Discard the O-ring seals.

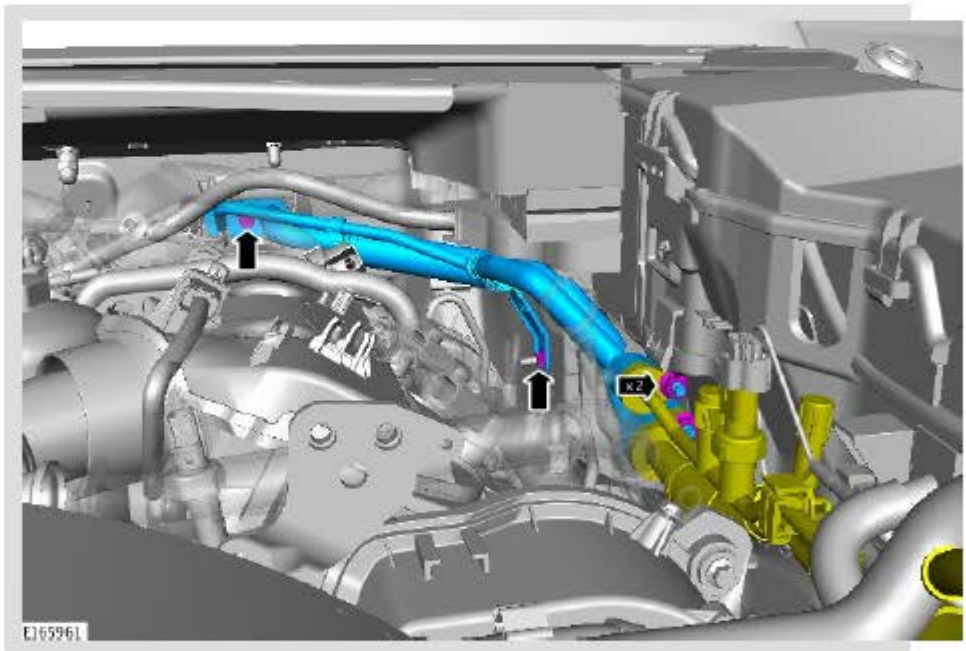

4.

# SAMPLE

**Cylinder head**

The aluminium cylinder head houses the chain driven overhead camshaft, the valve gear and fuel injectors.

Coolant enters the cylinder head from the crankcase. The coolant flow is across the cylinder head and out to the heater matrix and radiator.

An oil separator with wire mesh filter is installed in the camshaft cover.

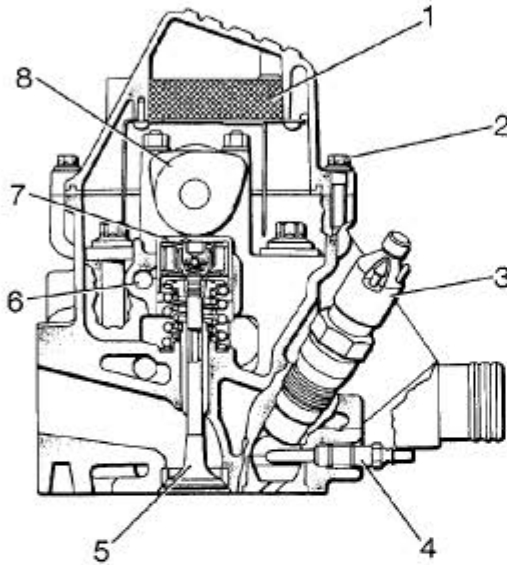

12M7137

- 1. Oil separator
- 2. Camshaft cover bolts
- 3. Fuel injector
- 4. Glow plug
- 5. Outlet valve
- 6. Oil supply duct
- 7. Hydraulic tappet
- 8. Camshaft

**Camshaft**

Seven bearings support the camshaft in the cylinder head. The camshaft is chain driven from the fuel injection pump drive sprocket, which itself is chain driven from the crankshaft. Both the injection pump timing chain and the camshaft timing chain run within guide rails and are tensioned automatically by tension rails and a chain adjuster mechanism.

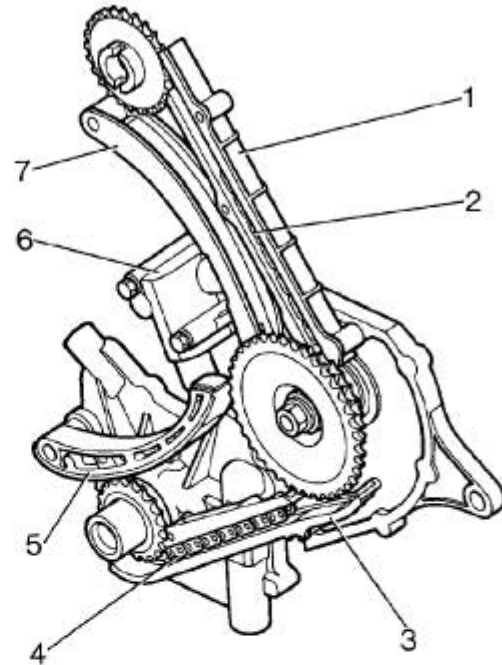

12M7138

- 1. Guide rail
- 2. Camshaft drive chain
- 3. Guide rail
- 4. Injection pump drive chain
- 5. Tension rail
- 6. Chain adjuster
- 7. Tension rail

**Valve gear**

The camshaft operates the inlet and exhaust valves through bucket-type tappets with hydraulic valve clearance adjustment. The hydraulic tappets are leakproof, eliminating rattle during the first few revolutions of the engine. Valves are available in standard size or oversize and are identified by a number stamped on the stem. Valves are coated during manufacture and DO NOT need to be lapped when they are renewed.

SAMPLE

## Bumpers - Front Bumper

### Removal and Installation

#### Removal

1.  **WARNING:** Do not work on or under a vehicle supported only by a jack. Always support the vehicle on safety stands.

Raise and support the vehicle.

2. Remove the front wheels and tires.

Refer to: [Wheel and Tire](#) (204-04 Wheels and Tires, Removal and Installation).

3. Remove the front bumper cover.

Refer to: [Front Bumper Cover](#) (501-19 Bumpers, Removal and Installation).

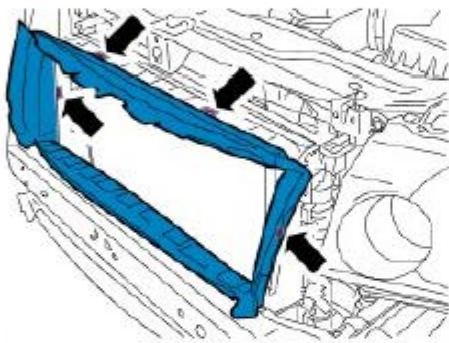

E73793

4.

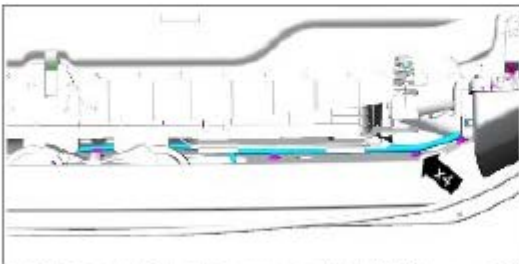

5.

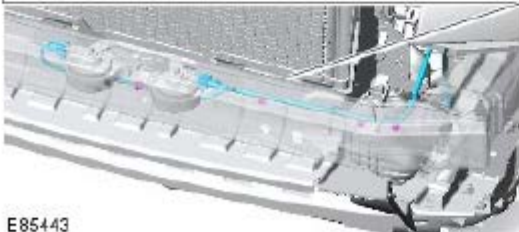

E85443

# SAMPLE

# Fuel Pressure Sensor - Petrol

## Electrical Revision Document No. 51291

### Circuit Fragment

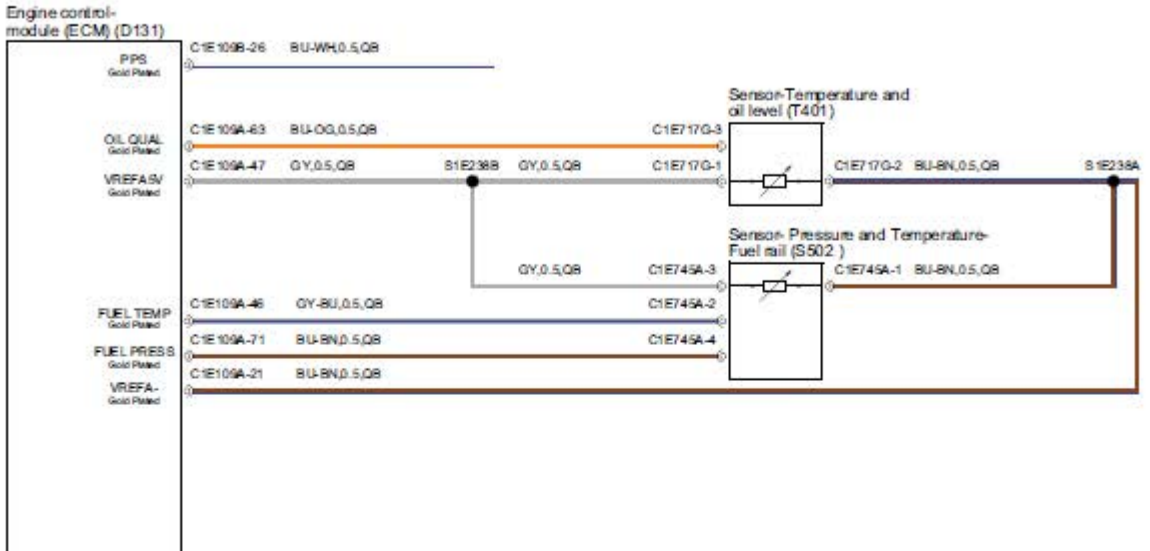

# SAMPLE

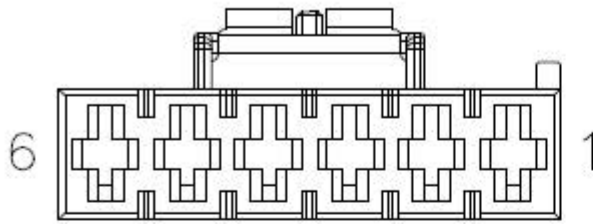

Connector: **C1BB01K****CONNECTOR HOUSING NOT SERVICEABLE**Description: **Junction box-engine**Location: **Rear LH side of engine compartment**Qualifier: **RHD condition Illustrated****NATURAL**Engineering Part Number: **DHCT-14489-DPB**

Service Part Number:

Colour: **NATURAL**Cavities: **6WY**Harness: **ENGINE COMPARTMENT RH HARNESS****Wire Chart and Service Repair Information**

Cav	CSA	Col	Cct	Destn	Pre-Terminated Lead	Extract Tool	Crimpers	Wire Stripper	Heat Shrink Sleeve	Ident Sleeve	Splice
1	4.0	RD	ALL	C1BB01N	418-581	-	418-116A	418-672	418-105	418-114	418-109
2	6.0	RD	(EN_U6/EN_U7)+ (G2AAB/G2AAG)	C1BF01H	418-581	-	418-116A	418-672	418-105	418-114	418-109
2	4.0	RD	(EN_U6/EN_U7)+G2AAF	S1SDF11	418-581	-	418-116A	418-672	418-105	418-114	418-109
3	6.0	RD	(EN_U6/EN_U7)+ (G2AAB/G2AAG)	C1BF01J	418-581	-	418-116A	418-672	418-105	418-114	418-109
3	6.0	RD	(EN_UQ/EN_XQ/EN_XR)+ (G2AAG/G2AAB)	C1BF01J	418-581	-	418-116A	418-672	418-105	418-114	418-109
3	6.0	RD	G2AAF	S1SDF10	418-581	-	418-116A	418-672	418-105	418-114	418-109
5	2.0	GY-BN	ALL	C1RW01	418-549-27	418-619	418-116A	418-672	418-104	418-113	418-108
6	2.0	BN-WH	ALL	C1RW01	418-549-27	418-619	418-116A	418-672	418-104	418-113	418-108

**SAMPLE**



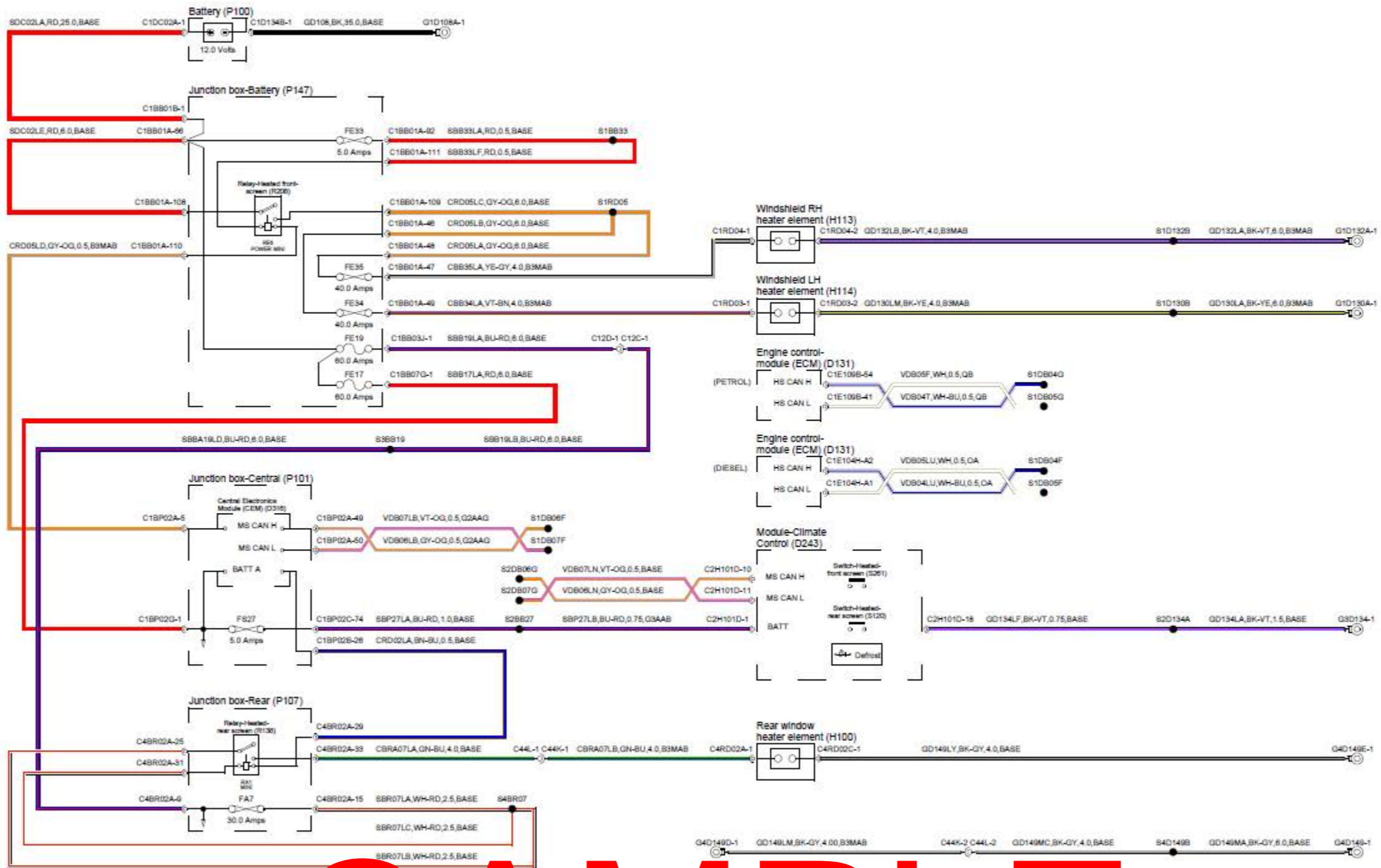

SAMPLE

Bookmarks

- 1Workshop Manual
- 2Accessory Fitting
- 3Electrical Information
- 4Maintenance
- 5Other Information
- 6Connector

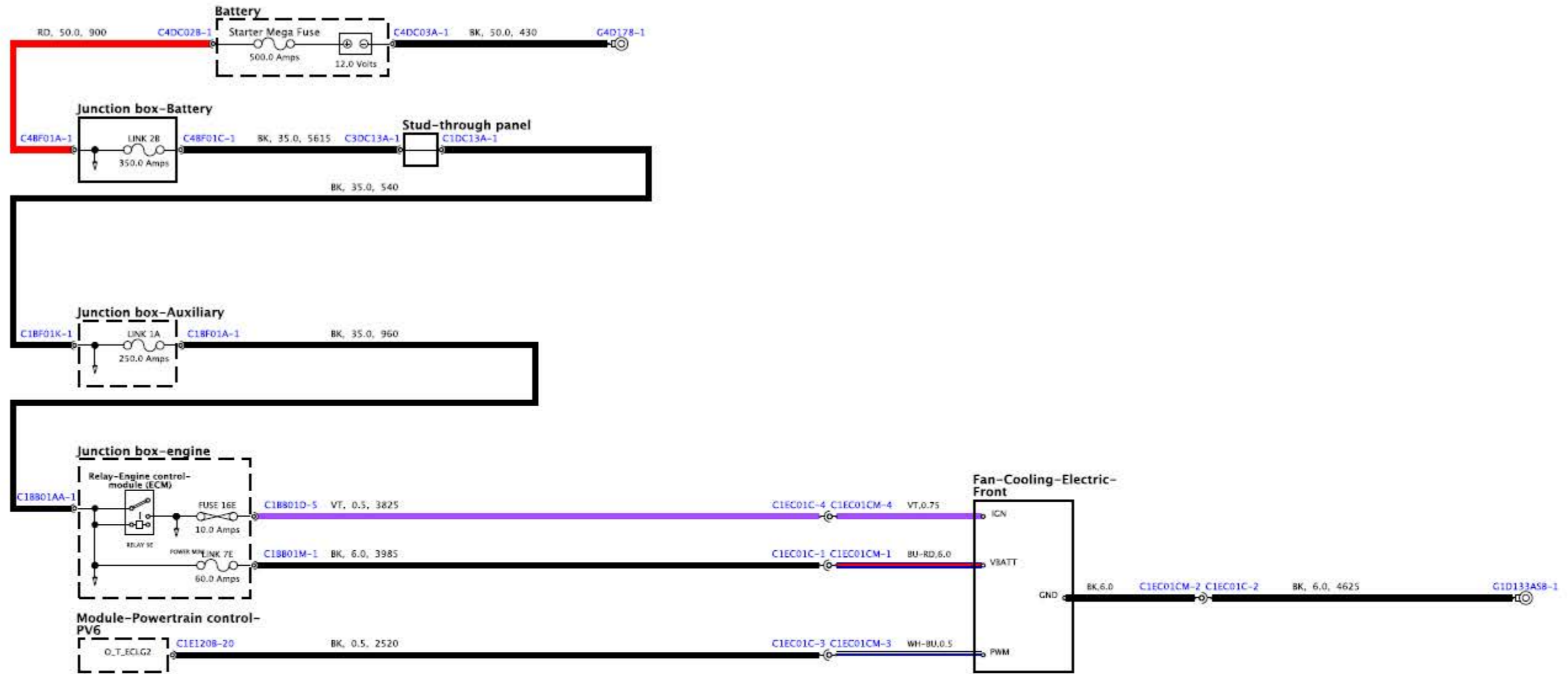

SAMPLE