

FOREWORD

This manual contains an introductory description on the SUZUKI DL1000 and procedures for its inspection/service and overhaul of its main components. Other information considered as generally known is not included.

Read the GENERAL INFORMATION section to familiarize yourself with the motorcycle and its maintenance. Use this section as well as other sections to use as a guide for proper inspection and service. This manual will help you know the motorcycle better so that you can assure your customers of fast and reliable service.

* This manual has been prepared on the basis of the latest specifications at the time of publication. If modifications have been made since then, differences may exist between the content of this manual and the actual motorcycle.

* Illustrations in this manual are used to show the basic principles of operation and work procedures. They may not represent the actual motorcycle exactly in detail.

* This manual is written for persons who have enough knowledge, skills and tools, including special tools, for servicing SUZUKI motorcycles. If you do not have the proper knowledge and tools, ask your authorized SUZUKI motorcycle dealer to help you.

▲ WARNING

Inexperienced mechanics or mechanics without the proper tools and equipment may not be able to properly perform the services described in this manual. Improper repair may result in injury to the mechanic and may render the motorcycle unsafe for the rider and passenger.

GROUP INDEX

GENERAL INFORMATION	1
PERIODIC MAINTENANCE	2
ENGINE	3
FI SYSTEM	4
COOLING AND LUBRICATION SYSTEM	5
CHASSIS	6
ELECTRICAL SYSTEM	7
SERVICING INFORMATION	8
EMISSION CONTROL INFORMATION	9
WIRING DIAGRAM	10

SUZUKI MOTOR CORPORATION

HOW TO USE THIS MANUAL

TO LOCATE WHAT YOU ARE LOOKING FOR:

1. The text of this manual is divided into sections.
2. The section titles are listed in the GROUP INDEX.
3. Holding the manual as shown at the right will allow you to find the first page of the section easily.
4. The contents are listed on the first page of each section to help you find the item and page you need.

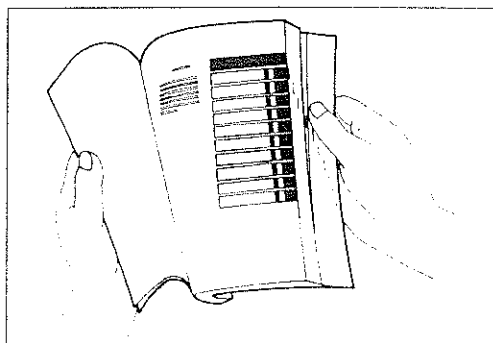

COMPONENT PARTS AND WORK TO BE DONE

Under the name of each system or unit, is its exploded view. Work instructions and other service information such as the tightening torque, lubricating points and locking agent points, are provided.

Example: Front wheel



















- ① Brake disc
- ② Dust seal
- ③ Bearing
- ④ Center spacer
- ⑤ Collar
- ⑥ Front wheel
- ⑦ Tire valve

- A Front axle
- B Brake disc bolt

ITEM	N·m	kgf·m	lb·ft
A	100	10.0	72.5
B	23	2.3	16.5

SYMBOL

Listed in the table below are the symbols indicating instructions and other information necessary for servicing. The meaning of each symbol is also included in the table.

SYMBOL	DEFINITION	SYMBOL	DEFINITION
	Torque control required. Data beside it indicates specified torque.		Use engine coolant.
	Apply oil. Use engine oil unless otherwise specified.		Use fork oil. 99000-99001-SS8
	Apply molybdenum oil solution. (Mixture of engine oil and SUZUKI MOLY PASTE in a ratio of 1 : 1)		Apply or use brake fluid.
	Apply SUZUKI SUPER GREASE "A". 99000-25030		Measure in voltage range.
	Apply SUZUKI MOLY PASTE. 99000-25140		Measure in current range.
	Apply SUZUKI BOND "1207B". 99104-31140		Measure in diode test range.
	Apply THREAD LOCK SUPER "1303". 99000-32030		Measure in continuity test range.
	Apply THREAD LOCK SUPER "1322". 99000-32110		Use special tool.
	Apply THREAD LOCK "1342". 99000-32050		Indication of service data.
	Apply THREAD LOCK SUPER "1360". 99000-32130		

ABBREVIATIONS USED IN THIS MANUAL

A

ABDC	: After Bottom Dead Center
AC	: Alternating Current
ACL	: Air Cleaner, Air Cleaner Box
API	: American Petroleum Institute
ATDC	: After Top Dead Center
ATM Pressure:	Atmospheric Pressure
	Atmospheric Pressure Sensor (APS)
A/F	: Air Fuel Mixture

B

BBDC	: Before Bottom Dead Center
BTDC	: Before Top Dead Center
B+	: Battery Positive Voltage

C

CKP Sensor	: Crankshaft Position Sensor (CKPS)
CKT	: Circuit
CLP Switch	: Clutch Lever Position Switch (Clutch Switch)
CMP Sensor	: Camshaft Position Sensor (CMPS)
CO	: Carbon Monoxide
CPU	: Central Processing Unit

D

DC	: Direct Current
DMC	: Dealer Mode Coupler
DOHC	: Double Over Head Camshaft
DRL	: Daytime Running Light

E

ECM	: Engine Control Module
	Engine Control Unit (ECU) (FI Control Unit)
ECT Sensor	: Engine Coolant Temperature Sensor (ECTS), Water Temp. Sensor (WTS)
EVAP	: Evaporative Emission
EVAP Canister:	Evaporative Emission Canister (Canister)

F

FI	: Fuel Injection, Fuel Injector
FP	: Fuel Pump
FPR	: Fuel Pressure Regulator
FP Relay	: Fuel Pump Relay

G

GEN	: Generator
GND	: Ground
GP Switch	: Gear Position Switch

H

HC	: Hydrocarbons
----	----------------

I

IAP Sensor	: Intake Air Pressure Sensor (IAPS)
IAT Sensor	: Intake Air Temperature Sensor (IATS)
IG	: Ignition

L

LCD	: Liquid Crystal Display
LED	: Light Emitting Diode (Malfunction Indicator Lamp)
LH	: Left Hand

M

MAL-Code : Malfunction Code
(Diagnostic Code)
Max : Maximum
MIL : Malfunction Indicator Lamp
(LED)
Min : Minimum

N

NOx : Nitrogen Oxides

O

OHC : Over Head Camshaft
OPS : Oil Pressure Switch

P

PCV : Positive Crankcase
Ventilation (Crankcase Breather)

R

RH : Right Hand
ROM : Read Only Memory

S

SAE : Society of Automotive Engineers
STC System : Secondary Throttle Control
System (STCS)
STP Sensor : Secondary Throttle Position
Sensor (STPS)
ST Valve : Secondary Throttle Valve (STV)
STV Actuator : Secondary Throttle Valve Actuator
(STVA)

T

TO Sensor : Tip Over Sensor (TOS)
TP Sensor : Throttle Position Sensor (TPS)

V

VD : Vacuum Damper

SAE-TO-FORMER SUZUKI TERM

This table lists SAE (Society of Automotive Engineers) J1930 terms and abbreviations which may be used in this manual in compliance with SAE recommendations, as well as their former SUZUKI names.

SAE TERM		FORMER SUZUKI TERM
FULL TERM	ABBREVIATION	
A		
Air Cleaner	ACL	Air Cleaner, Air Cleaner Box
B		
Barometric Pressure	BARO	Barometric Pressure, Atmospheric Pressure (APS, AP Sensor)
Battery Positive Voltage	B+	Battery Voltage, +B
C		
Camshaft Position Sensor	CMP Sensor	Camshaft Position Sensor (CMPS)
Crankshaft Position Sensor	CKP Sensor	Crankshaft Position Sensor (CKPS), Crank Angle
D		
Data Link Connector	DLC	Dealer Mode Coupler
Diagnostic Test Mode	DTM	—
Diagnostic Trouble Code	DTC	Diagnostic Code, Malfunction Code
E		
Electronic Ignition	EI	—
Engine Control Module	ECM	Engine Control Module (ECM) FI Control Unit, Engine Control Unit (ECU)
Engine Coolant Level	ECL	Coolant Level
Engine Coolant Temperature	ECT	Coolant Temperature, Engine Coolant Temperature Water Temperature
Engine Speed	RPM	Engine Speed (RPM)
Evaporative Emission	EVAP	Evaporative Emission
Evaporative Emission Canister	EVAP Canister	— (Canister)
Exhaust Control System	EXCS	EXC System (EXCS)
Exhaust Control Valve	EXCV	EXC Valve (EXCV)
Exhaust Control Valve Actuator	EXCVA	EXCV Actuator (EXCVA)
Purge Valve	Purge Valve	Purge Valve (SP Valve)
F		
Fan Control	FC	—
Fuel Level Sensor	—	Fuel Level Sensor, Fuel Level Gauge
Fuel Pump	FP	Fuel Pump (FP)

SAE TERM		FORMER SUZUKI TERM
FULL TERM	ABBREVIATION	
G		
Generator	GEN	Generator
Ground	GND	Ground (GND, GRD)
I		
Idle Speed Control	ISC	—
Ignition Control	IC	Electronic Spark Advance (ESA)
Ignition Control Module	ICM	—
Intake Air Temperature	IAT	Intake Air Temperature (IAT), Air Temperature
M		
Malfunction Indicator Lamp	MIL	LED Lamp Malfunction Indicator Lamp (MIL)
Manifold Absolute Pressure	MAP	Intake Air Pressure, Intake Vacuum
Mass Air Flow	MAF	Air Flow
O		
On-Board Diagnostic	OBD	Self-Diagnosis Function Diagnostic
Open Loop	OL	—
P		
Programmable Read Only Memory	PROM	—
Pulsed Secondary Air Injection	PAIR	Pulse Air Control (PAIR)
R		
Random Access Memory	RAM	—
Read Only Memory	ROM	ROM
S		
Secondary Air Injection	AIR	—
Secondary Throttle Control System	STCS	STC System (STCS)
Secondary Throttle Valve	STV	ST Valve (STV)
Secondary Throttle Valve Actuator	STVA	STV Actuator (STVA)
T		
Throttle Body	TB	Throttle Body (TB)
Throttle Body Fuel Injection	TBI	Throttle Body Fuel Injection (TBI)
Throttle Position Sensor	TP Sensor	TP Sensor (TPS)
V		
Voltage Regulator	VR	Voltage Regulator
Volume Air Flow	VAF	Air Flow

GENERAL INFORMATION

1

CONTENTS

WARNING/CAUTION/NOTE	1- 2
GENERAL PRECAUTIONS	1- 2
SUZUKI DL1000K2 ('02-MODEL)	1- 4
SERIAL NUMBER LOCATION	1- 4
FUEL, OIL AND ENGINE COOLANT RECOMMENDATION	1- 4
FUEL	1- 4
ENGINE OIL	1- 5
BRAKE FLUID	1- 5
FRONT FORK OIL	1- 5
ENGINE COOLANT	1- 5
WATER FOR MIXING	1- 5
ANTI-FREEZE/ENGINE COOLANT	1- 5
LIQUID AMOUNT OF WATER/ENGINE COOLANT	1- 5
BREAK-IN PROCEDURES	1- 6
CYLINDER IDENTIFICATION	1- 6
INFORMATION LABELS	1- 7
SPECIFICATIONS	1- 8
COUNTRY AND AREA CODES	1-10

WARNING/CAUTION/NOTE

Please read this manual and follow its instructions carefully. To emphasize special information, the symbol and the words WARNING, CAUTION and NOTE have special meanings. Pay special attention to the messages highlighted by these signal words.

▲ WARNING

Indicates a potential hazard that could result in death or injury.

CAUTION

Indicates a potential hazard that could result in motorcycle damage.

NOTE:

Indicates special information to make maintenance easier or instructions clearer.

Please note, however, that the warnings and cautions contained in this manual cannot possibly cover all potential hazards relating to the servicing, or lack of servicing, of the motorcycle. In addition to the WARNINGS and CAUTIONS stated, you must use good judgement and basic mechanical safety principles. If you are unsure about how to perform a particular service operation, ask a more experienced mechanic for advice.

GENERAL PRECAUTIONS

▲ WARNING

- * Proper service and repair procedures are important for the safety of the service mechanic and the safety and reliability of the motorcycle.
- * When 2 or more persons work together, pay attention to the safety of each other.
- * When it is necessary to run the engine indoors, make sure that exhaust gas is forced outdoors.
- * When working with toxic or flammable materials, make sure that the area you work in is well-ventilated and that you follow all of the material manufacturer's instructions.
- * Never use gasoline as a cleaning solvent.
- * To avoid getting burned, do not touch the engine, engine oil, radiator and exhaust system until they have cooled.
- * After servicing the fuel, oil, water, exhaust or brake systems, check all lines and fittings related to the system for leaks.

CAUTION

- * If parts replacement is necessary, replace the parts with Suzuki Genuine Parts or their equivalent.
 - * When removing parts that are to be reused, keep them arranged in an orderly manner so that they may be reinstalled in the proper order and orientation.
 - * Be sure to use special tools when instructed.
 - * Make sure that all parts used in reassembly are clean. Lubricate them when specified.
 - * Use the specified lubricant, bond, or sealant.
 - * When removing the battery, disconnect the negative cable first and then the positive cable. When reconnecting the battery, connect the positive cable first and then the negative cable, and replace the terminal cover on the positive terminal.
 - * When performing service to electrical parts, if the service procedures not require use of battery power, disconnect the negative cable the battery.
 - * When tightening the cylinder head and case bolts and nuts, tighten the larger sizes first. Always tighten the bolts and nuts diagonally from the inside toward outside and to the specified tightening torque.
 - * Whenever you remove oil seals, gaskets, packing, O-rings, locking washers, self-locking nuts, cotter pins, circlips and certain other parts as specified, be sure to replace them with new ones. Also, before installing these new parts, be sure to remove any left over material from the mating surfaces.
 - * Never reuse a circlip. When installing a new circlip, take care not to expand the end gap larger than required to slip the circlip over the shaft. After installing a circlip, always ensure that it is completely seated in its groove and securely fitted.
 - * Use a torque wrench to tighten fasteners to the specified torque. Wipe off grease and oil if a thread is smeared with them.
 - * After reassembling, check parts for tightness and proper operation.
-
- * To protect the environment, do not unlawfully dispose of used motor oil, engine coolant and other fluids: batteries, and tires.
 - * To protect Earth's natural resources, properly dispose of used motorcycle and parts.

SUZUKI DL1000K2 ('02-MODEL)

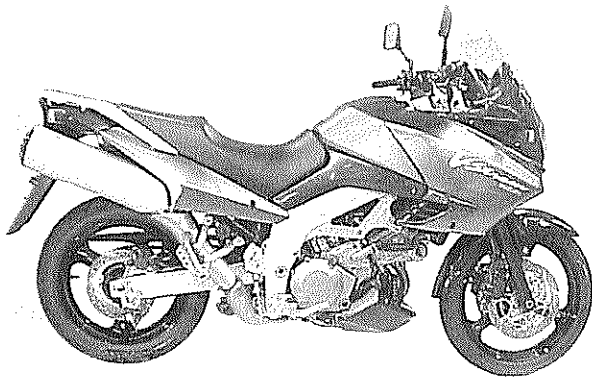

RIGHT SIDE

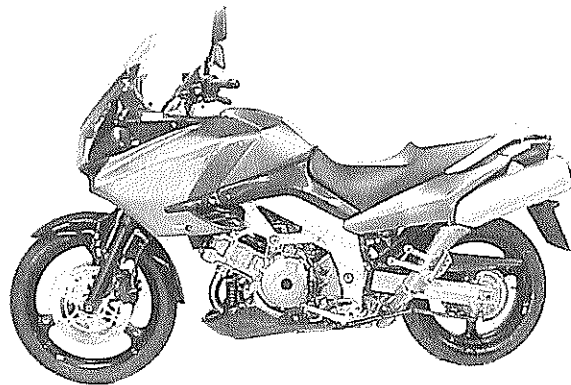

LEFT SIDE

* Difference between photographs and actual motorcycles may exist depending on the markets.

SERIAL NUMBER LOCATION

The frame serial number or V.I.N. (Vehicle Identification Number) ① is stamped on the right side of the steering head pipe. The engine serial number ② is located on the right side of the crankcase. These numbers are required especially for registering the machine and ordering spare parts.

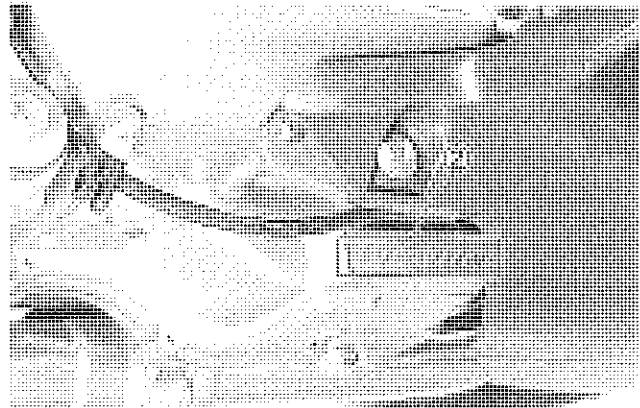

FUEL, OIL AND ENGINE COOLANT RECOMMENDATION

FUEL (FOR USA MODEL)

Use only unleaded gasoline of at least 87 pump octane ($\frac{R+M}{2}$) or 91 octane or higher rated by the research method.

Gasoline containing MTBE (Methyl Tertiary Butyl Ether), less than 10% ethanol, or less than 5% methanol with appropriate cosolvents and corrosion inhibitor is permissible.

FUEL (FOR OTHER COUNTRIES)

Gasoline used should be graded 91 octane (Research Method) or higher. Unleaded gasoline is recommended.

ENGINE OIL

SUZUKI recommends the use of SUZUKI PERFORMANCE 4 MOTOR OIL or an oil which is rated SF or SG under the API (American Petroleum Institute) service classification. The recommended viscosity is SAE 10W-40. If an SAE 10W-40 oil is not available, select an alternative according to the right chart.

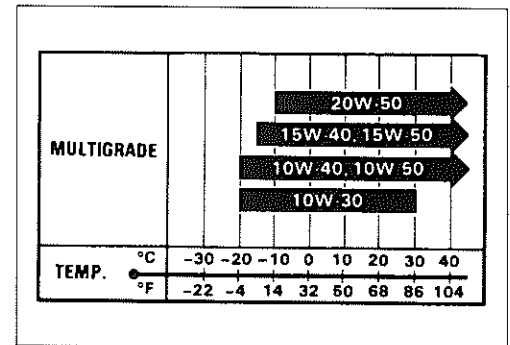

BRAKE FLUID

Specification and classification: DOT 4

▲ WARNING

Since the brake system of this motorcycle is filled with a glycol-based brake fluid by the manufacturer, do not use or mix different types of fluid such as silicone-based and petroleum-based fluid for refilling the system, otherwise serious damage will result.

Do not use any brake fluid taken from old or used or unsealed containers.

Never re-use brake fluid left over from a previous servicing, which has been stored for a long period.

FRONT FORK OIL

Use fork oil SS8 or an equivalent fork oil.

ENGINE COOLANT

Use an anti-freeze/engine coolant compatible with an aluminum radiator, mixed with distilled water only.

WATER FOR MIXING

Use distilled water only. Water other than distilled water can corrode and clog the aluminum radiator.

ANTI-FREEZE/ENGINE COOLANT

The engine coolant perform as a corrosion and rust inhibitor as well as anti-freeze. Therefore, the engine coolant should be used at all times even though the atmospheric temperature in your area does not go down to freezing point.

Suzuki recommends the use of SUZUKI COOLANT anti-freeze/engine coolant. If this is not available, use an equivalent which is compatible with an aluminum radiator.

LIQUID AMOUNT OF WATER/ENGINE COOLANT

Solution capacity (total): 2 200 ml (2.3/1.9 US/Imp qt)

For engine coolant mixture information, refer to cooling system section, page 5-2.

CAUTION

Mixing of anti-freeze/engine coolant should be limited to 60%. Mixing beyond it would reduce its efficiency. If the anti-freeze/engine coolant mixing ratio is below 50%, rust inhabiting performance is greatly reduced. Be sure to mix it above 50% even though the atmospheric temperature does not go down to the freezing point.

BREAK-IN PROCEDURES

During manufacture only the best possible materials are used and all machined parts are finished to a very high standard but it is still necessary to allow the moving parts to "BREAK-IN" before subjecting the engine to maximum stresses. The future performance and reliability of the engine depends on the care and restraint exercised during its early life. The general rules are as follows.

- Keep to these break-in engine speed limits:

Initial 800 km (500 miles): Below 4 500 r/min

Up to 1 600 km (1 000 miles): Below 7 000 r/min

Over 1 600 km (1 000 miles): Below 9 500 r/min

- Upon reaching an odometer reading of 1 600 km (1 000 miles) you can subject the motorcycle to full throttle operation. However, do not exceed 9 500 r/min at any time.

CYLINDER IDENTIFICATION

The two cylinders of this engine are identified as No.1 and No.2 cylinder, as counted from front to rear (as viewed by the rider on the seat).

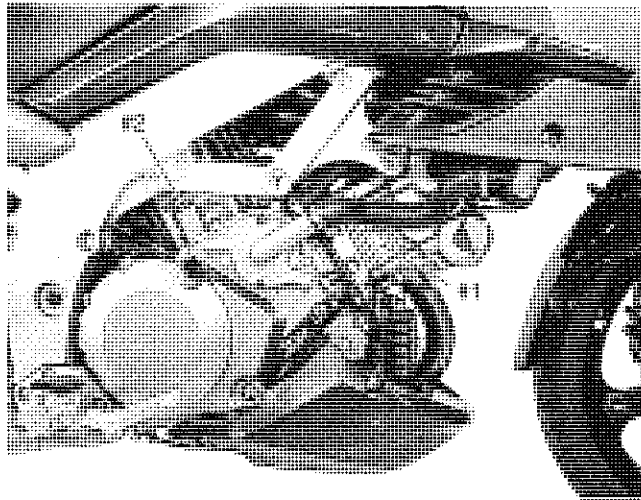

INFORMATION LABELS

①	Noise label (For E-03, 24, 33)
②	Information label (For E-03, 28, 33)
③	ICES Canada label (For E-28)
④	Vacuum hose routing label (For E-33)
⑤	Fuel caution label (For E-02, 24)
⑥	Manual notice label (For E-03, 33)
⑦	Tire pressure label
⑧	Warning safety label
⑨	Rear carrier warning label
⑩	Frame caution label
⑪	Steering warning label
⑫	Screen warning label
⑬	ID label (For E-02, 19, 24)
⑭	Safety label (For E-03, 28, 33)

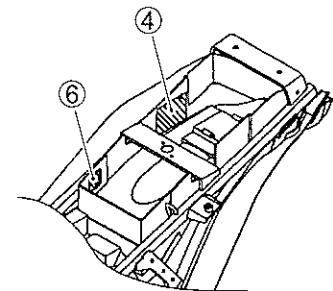
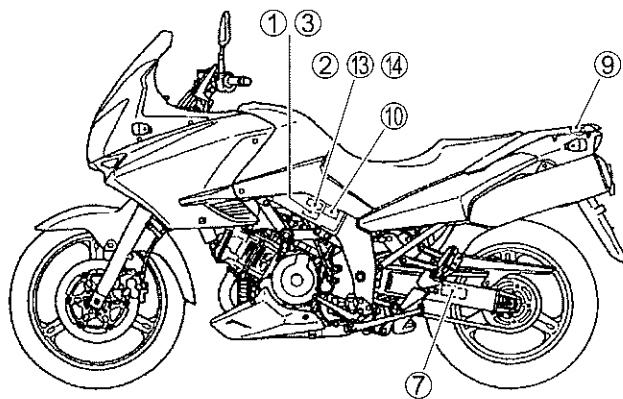
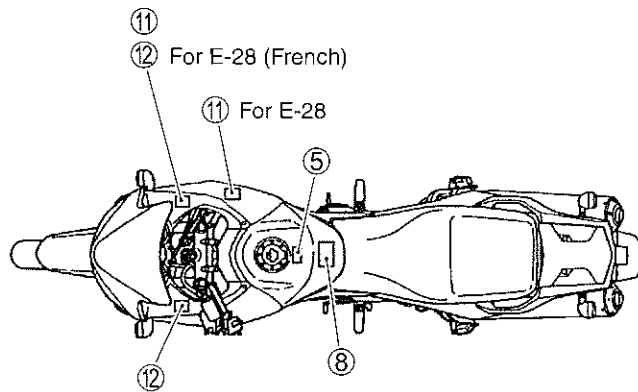

SPECIFICATIONS

DIMENSIONS AND DRY MASS

Overall length.....	2 295 mm (90.4 in)
Overall width	865 mm (34.1 in)
Overall height.....	1 335 mm (52.6 in)
Wheelbase.....	1 535 mm (60.4 in)
Ground clearance	165 mm (6.5 in)
Seat height.....	840 mm (33.1 in)
Dry mass.....	207 kg (456 lbs)
	209 kg (461 lbs)E-33

ENGINE

Type	Four-stroke, Liquid-cooled, DOHC, 90-degree V-twin
Number of cylinders	2
Bore	98.0 mm (3.858 in)
Stroke.....	66.0 mm (2.598 in)
Piston displacement.....	996 cm ³ (60.8 cu. in)
Compression ratio.....	11.3 : 1
Fuel system.....	Fuel injection system
Air cleaner.....	Non-woven fabric element
Starter system.....	Electric starter
Lubrication system	Wet sump

DRIVE TRAIN

Clutch.....	Wet multi-plate type
Transmission.....	6-speed constant mesh
Gearshift pattern	1-down, 5-up
Primary reduction ratio.....	1.838 (57/31)
Final reduction ratio	2.411 (41/17)
Gear ratios, Low	3.000 (36/12)
2nd.....	1.933 (29/15)
3rd	1.500 (27/18)
4th.....	1.227 (27/22)
5th.....	1.086 (25/23)
Top	0.913 (21/23)
Drive chain	RK525 SMOZ7, 112 links

CHASSIS

Front suspension.....	Inverted telescopic, coil spring, oil damped
Rear suspension	Link type, coil spring, oil damped
Steering angle	40° (right & left)
Caster.....	26° 30'
Trail	111 mm (4.3 in)
Turning radius	2.7 m (8.86 ft)
Front brake	Disc brake, twin
Rear brake	Disc brake
Front tire size	110/80 R19M/C 59H, tubeless
Rear tire size	150/70 R17M/C 69H, tubeless
Front fork stroke	160 mm (6.3 in)
Rear wheel travel.....	159 mm (6.2 in)

ELECTRICAL

Ignition type	Electronic ignition (ECM, Transistorized)
Ignition timing	4° B. T. D. C at 1 200 r/min
Spark plug	NGK: CR8EK or DENSO: U24ETR
Battery	12 V 43.2 kC (12 Ah)/10 HR
Generator	Three-phase A.C. Generator
Fuse	30/15/15/15/15/10 A
Headlight.....	12 V 60/55 W H4
Position light.....	12 V 5 W × 2.....Except for E-03, 24, 28, 33
Turn signal light.....	12 V 10 W
License light	12 V 5 W
Brake light/Taillight.....	12 V 21/5 W ×2
Speedometer/Tachometer light.....	LED
Neutral indicator light	LED
High beam indicator light.....	LED
Turn signal indicator light	LED
Over drive indicator light	LED
Fuel indicator warning light	LED
Engine coolant temperature warning light.....	LED
Oil pressure warning light.....	LED

CAPACITIES

Fuel tank	22 L (5.8/4.8 US/Imp gal)
Engine oil, oil change	2 700 ml (2.9/2.4 US/Imp qt)
with filter change.....	2 900 ml (3.1/2.6 US/Imp qt)
overhaul.....	3 300 ml (3.5/2.9 US/Imp qt)
Engine coolant, including reserve	2 200 ml (2.3/1.9 US/Imp oz)
Front fork oil (each leg)	505 ml (17.1/17.8 US/Imp oz)

These specifications are subject to change without notice.

COUNTRY AND AREA CODES

The following codes stand for the applicable country(-ies) and area(-s).

CODE	COUNTRY or AREA
E-02	U. K.
E-03	U. S. A. (Except for California)
E-19	EU
E-24	Australia
E-28	Canada
E-33	California (U. S. A.)

WIRING DIAGRAM

FI SYSTEM WIRING DIAGRAM

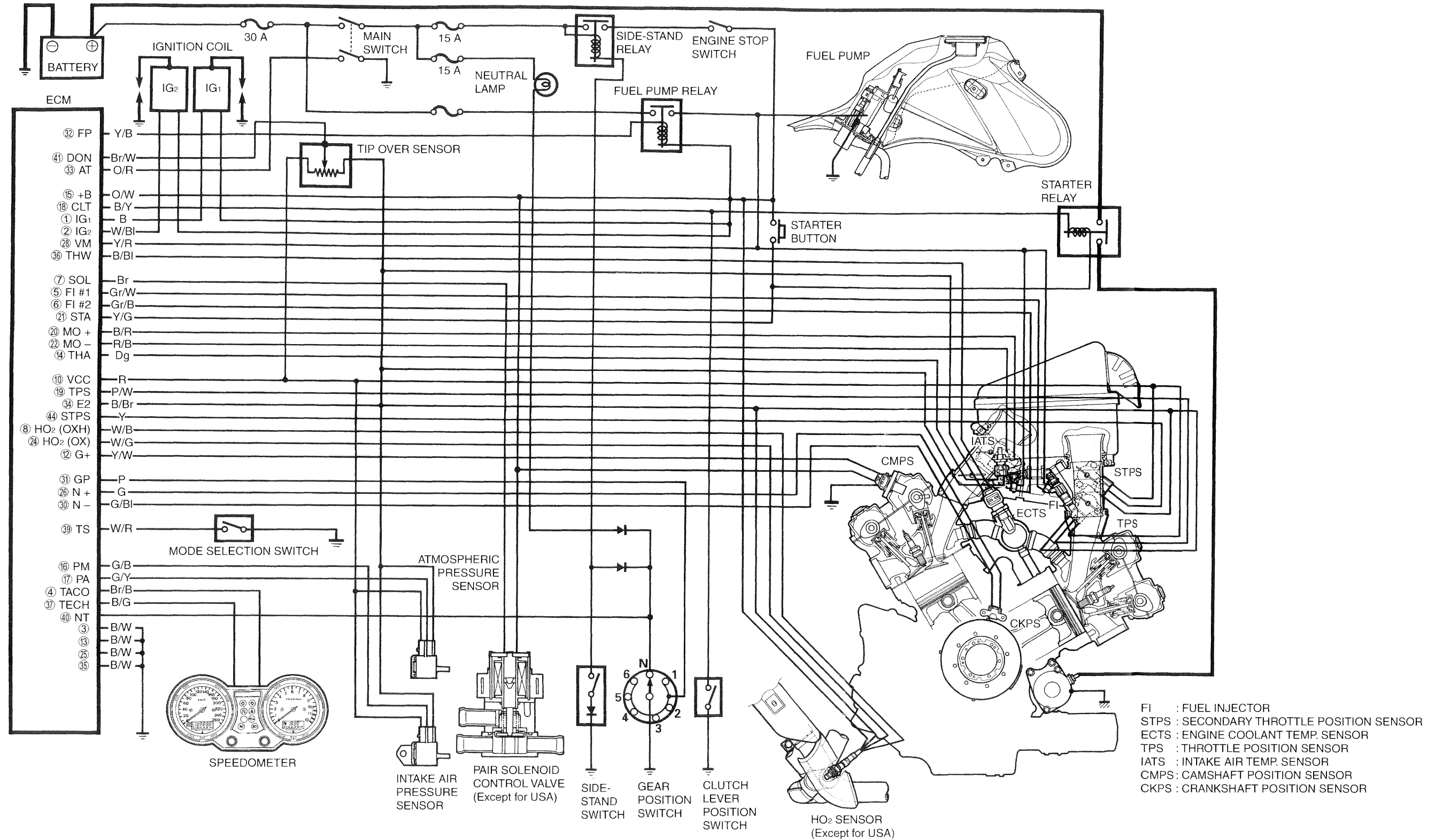

WIRING DIAGRAM

E-02, 19

