

GENERAL INFORMATION

1. VEHICLE MODELS

Model code	Destination	Engine	Catalyzer	Fuel evap. canister	Fuel system
F300RC-FMDS	General	HD-C	N/A	N/A	Carburetor
F300RG-BMDS -BMHS				Canister (Only G.C.C.)	
F300LC-FMDS					
F300LG-BMDS -BMHS					
F300RC-FMDSW	Europe	HD-C	N/A	N/A	Carburetor
F300RG-BMDSW -BMHSW					
F300LC-FMDSW					
F300LG-BMDSW -BMHSW					
F300RC-FMDEW	Europe	HD-E	3-WAY	Canister	EFI ⁽¹⁾
F300RG-BMHEW					
F300LC-FMDEW					
F300LG-BMDEW -BMHEW					
F300RC-FMDEQ	Australia	HD-E	3-WAY	Canister	EFI ⁽¹⁾
F300RG-BMDEQ -BMHEQ					

Note: (1) Electronic Fuel Injection

WFE90-GI002

EXPLANATION OF VEHICLE MODEL CODE

F 300 R C - F M D E W

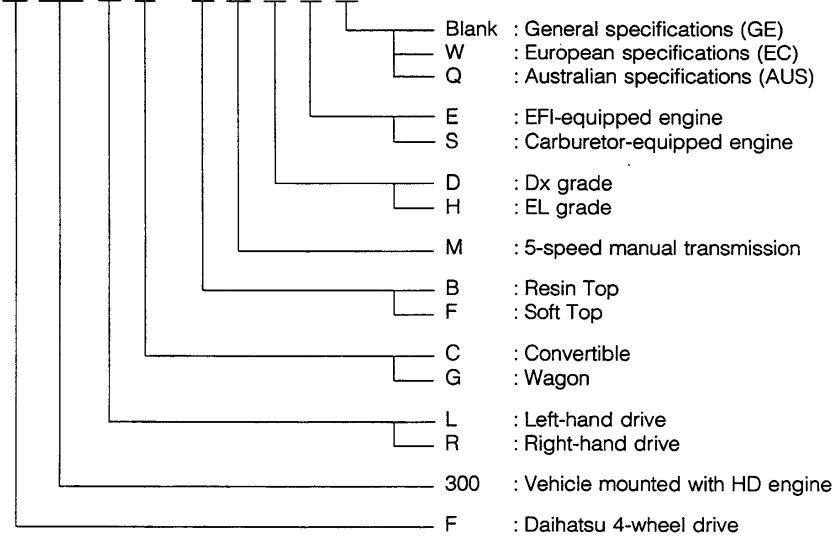

WFE90-GI003

GENERAL INFORMATION

2. CHASSIS SERIAL NUMBER & MANUFACTURER'S PLATE

FIRST CHASSIS SERIAL NUMBER

F300LC-
F300LG-

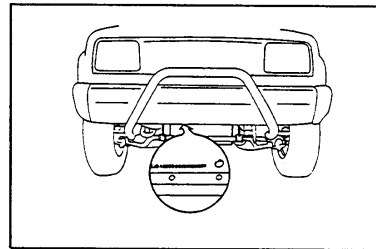

WFE90-G1004

CHASSIS NUMBER & MANUFACTURER'S PLATE

1. Position

The chassis number is stamped on the crossmember at the front section of the vehicle.
Manufacturer's plate is attached on the cowl panel.

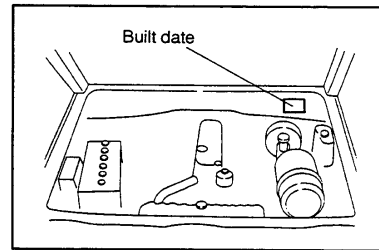

WFE90-G1005

2. Contents of manufacturer's plate

(1) General & Australian Specification

①	DAIHATSU MOTOR CO. LTD. JAPAN		
②	TYPE		
③	CHASSIS NO		
④	ENGINE		
	○	COLOR	TRIM ○
⑥	BUILT DATE		
		ENGINE NO	
	ダイハツ工業株式会社		⑨

- ① Manufacturer's name, Country
- ② Vehicle model
- ③ Chassis No.
- ④ Engine type
- ⑤ Engine displacement
- ⑥ Body colors
- ⑦ Trim code
- ⑧ Engine number
- ⑨ Manufacturer's name in Japanese
- ⑩ Gross vehicle weight
- ⑪ Gross combination weight
- ⑫ Maximum permissible front axle weight
- ⑬ Maximum permissible rear axle weight
- ⑭ Production month-year. (Only for AUS spec.)

(2) European Specification

①	DAIHATSU MOTOR CO..LTD		
			③
		Kg	⑩
		Kg	⑪
	1	Kg	⑫
	2	Kg	⑬
②	TYPE		
④	ENGINE		COLOR

WTF90-G1007

GENERAL INFORMATION

3. ENGINE NUMBER AND ENGINE TYPE

The engine type and serial number is stamped on the place as shown in the illustration.

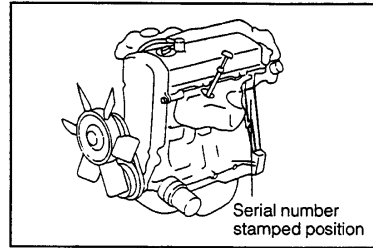

WFE90-GI006

4. BODY COLOR INFORMATION

Body color	Daihatsu color code	Stripe color		
		A	B	C
Red Gray M. San Remo green/Grey M.	3E7 168 NB1 (G09/168)	Dark Gray Metallic	Silver Metallic	Dark Blue
Green Dark blue M. Black M. Red mica/silver M. Dark blue M./silver M. Black M./silver M. White/silver M. White	G05 8G4 6A5 NA1 (3H1/148) NA2 (8G4/148) NA3 (6A5/148) NA4 (045/148) 045		Gray Metallic	Red

WFE90-GI007

COLOR CODE OF THE WORLD

COLOR		AXZO	DUPONT	I.C.I	SPIES HECKER	STANDOX
WHITE	045	DAH045	L8997	NW-80	16067	045
RED	3E7	DAH3E7	G8690	KK26	38299	3E7
GREEN	G05	DAHG05	G8691	KV77	68470	G05
GRAY. M	168	DAH168	N8832	B936B	97728	168
DARK BLUE. M	8G4	DAH8G4	K9131	C247B	97909	8G4
BLACK. M	6A5	DAH6A5	G8742	A403B	97806	6A5
TWO TONE	NA1	DAHNA1	G8730/N8221	PC86B/0985B	47840	NA1
TWO TONE	NA2	DAHNA2	K9131/N8221	C247B/0985B	48225	NA2
TWO TONE	NA3	DAHNA3	G8742/N8221	A403/0985B	48231	NA3
TWO TONE	NA4	DAHNA4	L8997/N8221	NW80/0985B	48232	NA4
TWO TONE	NB1	DAHNB1	N9305/N8832	XW13/B936B	48480	NB1

WFE90-GI100

BODY STRIPE INFORMATION

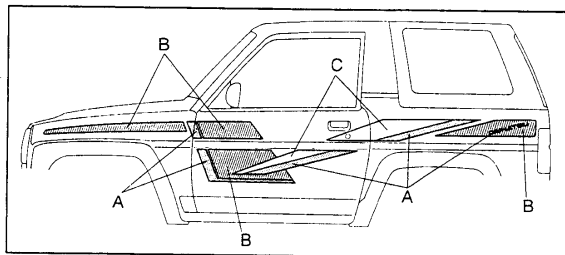

WFE90-GI101

5. VEHICLE 4-PLANE DIAGRAMS

Version: A (Resin top)

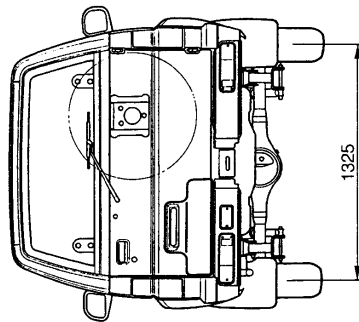
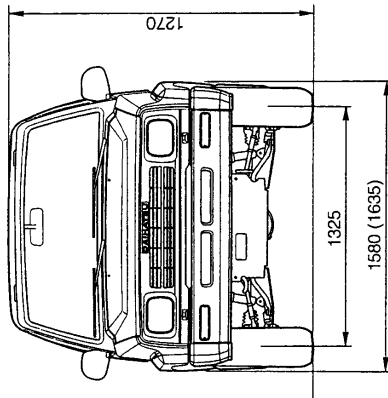
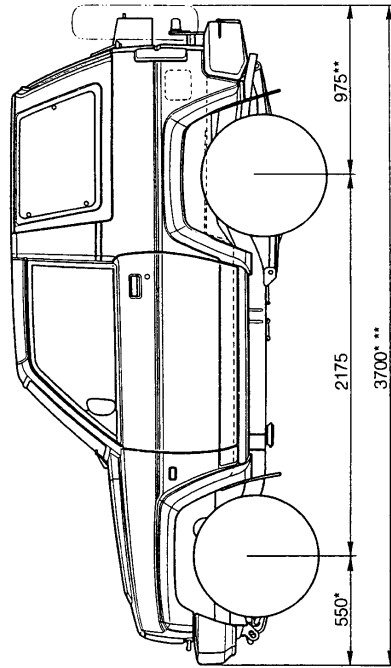
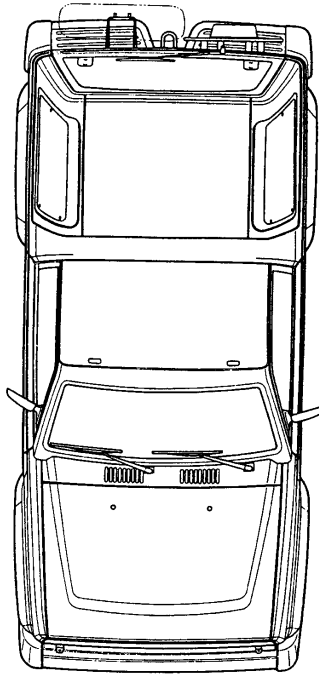

- () : with over-fenders
- * : +70 with front large bumper
- ** : +15 with 225/70R15 tyres

WFE90-G1009

GENERAL INFORMATION

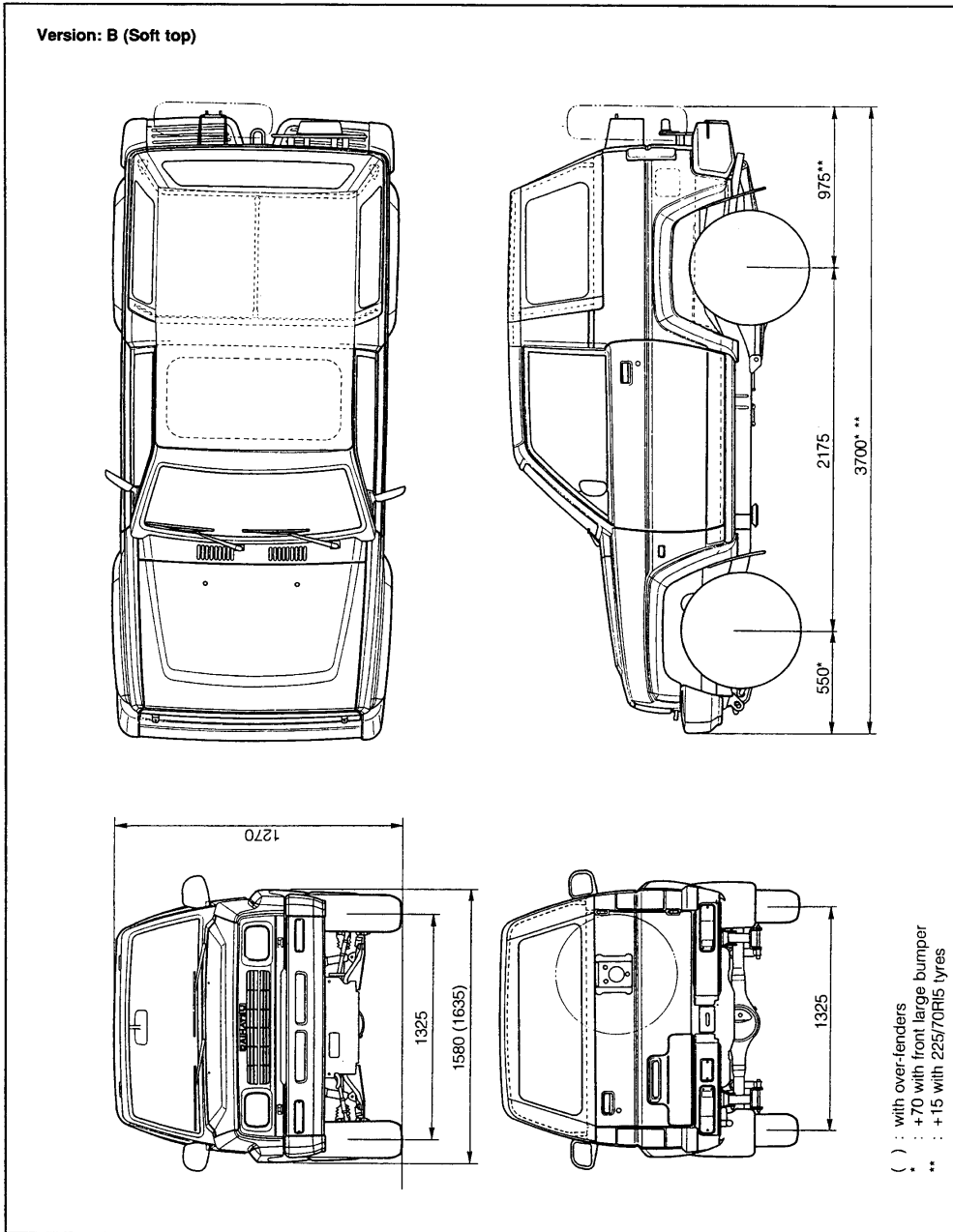

WFES0-GI010

GENERAL INFORMATION

Version: C (Soft top)

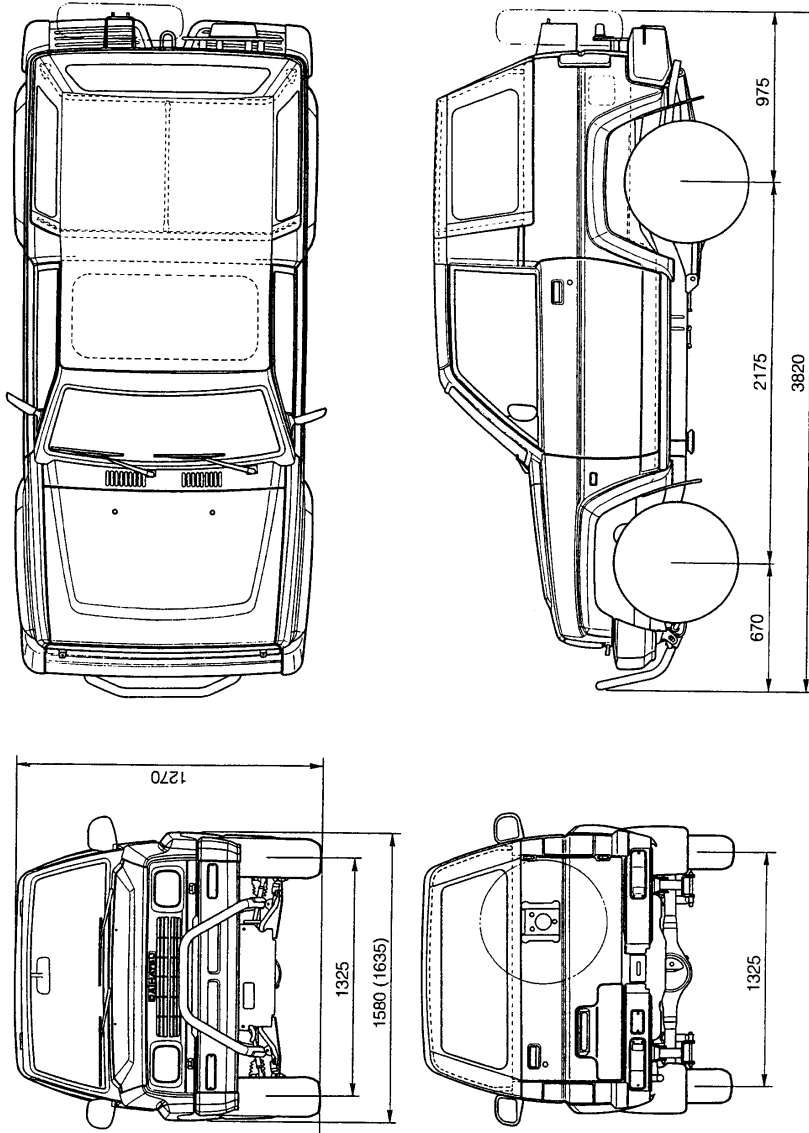

WFE90-G1101

GENERAL INFORMATION

Version: D (Soft top)

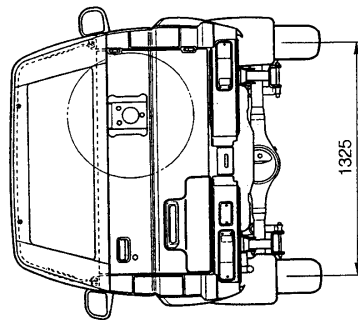
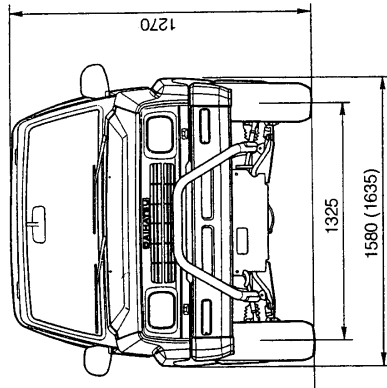
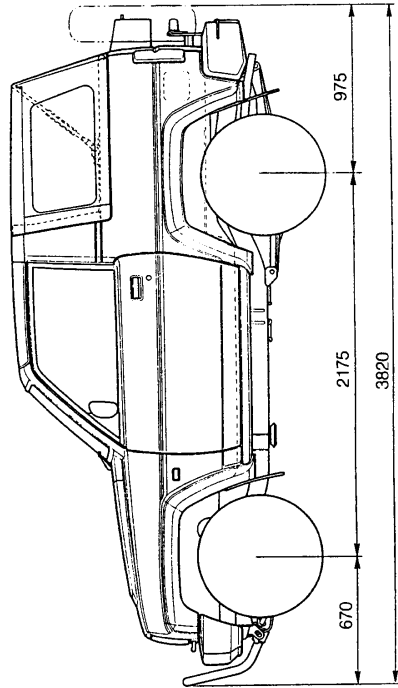
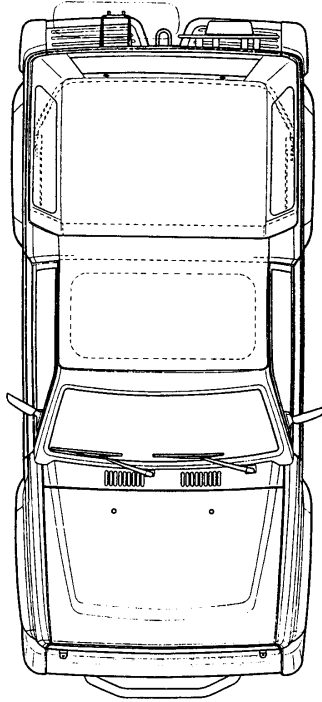

WFE90-GI102

6. PERFORMANCE DIAGRAMS

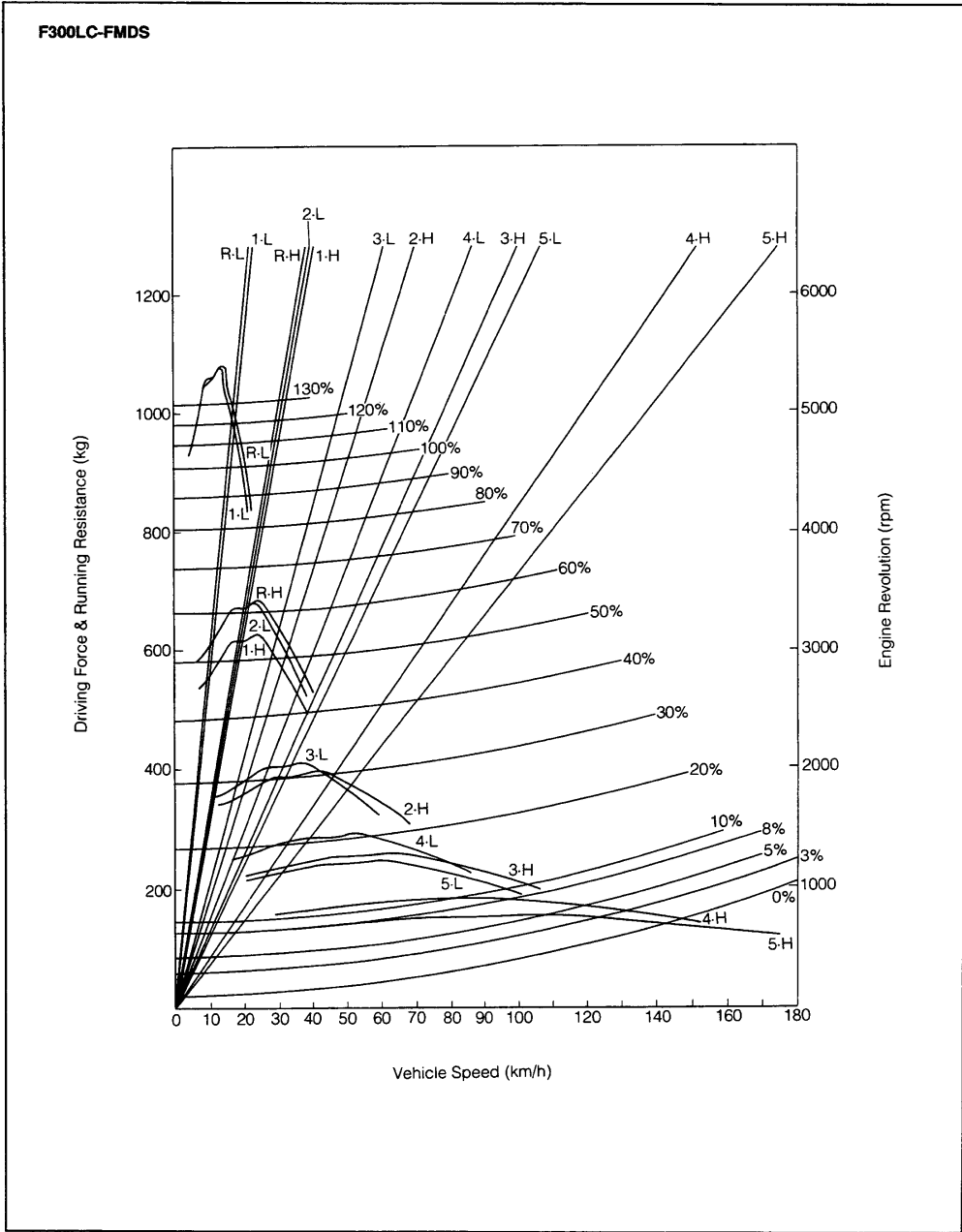

WFE90-G1011

GENERAL INFORMATION

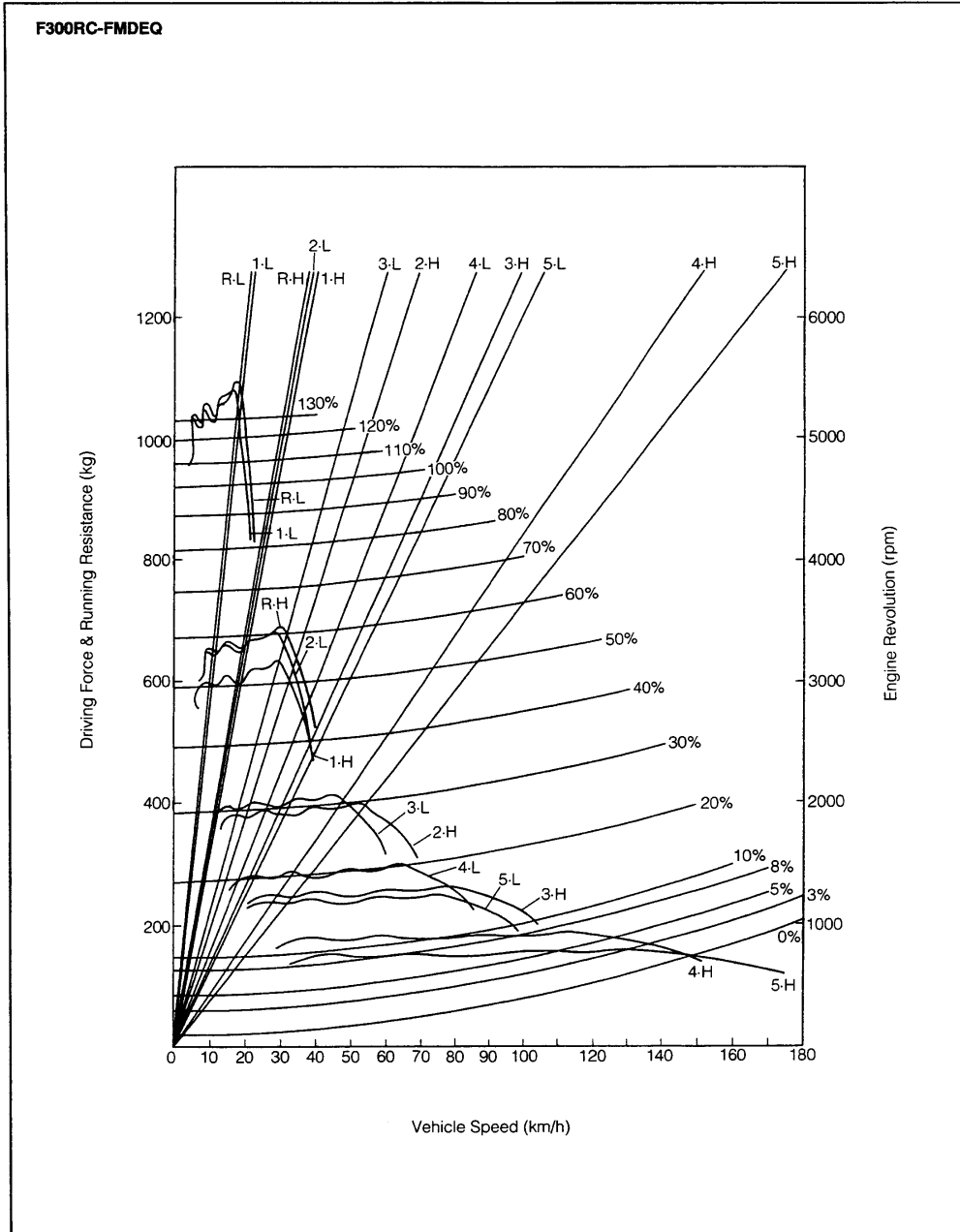

WFE90-GI012

GENERAL INFORMATION

F300LG-BMHEW

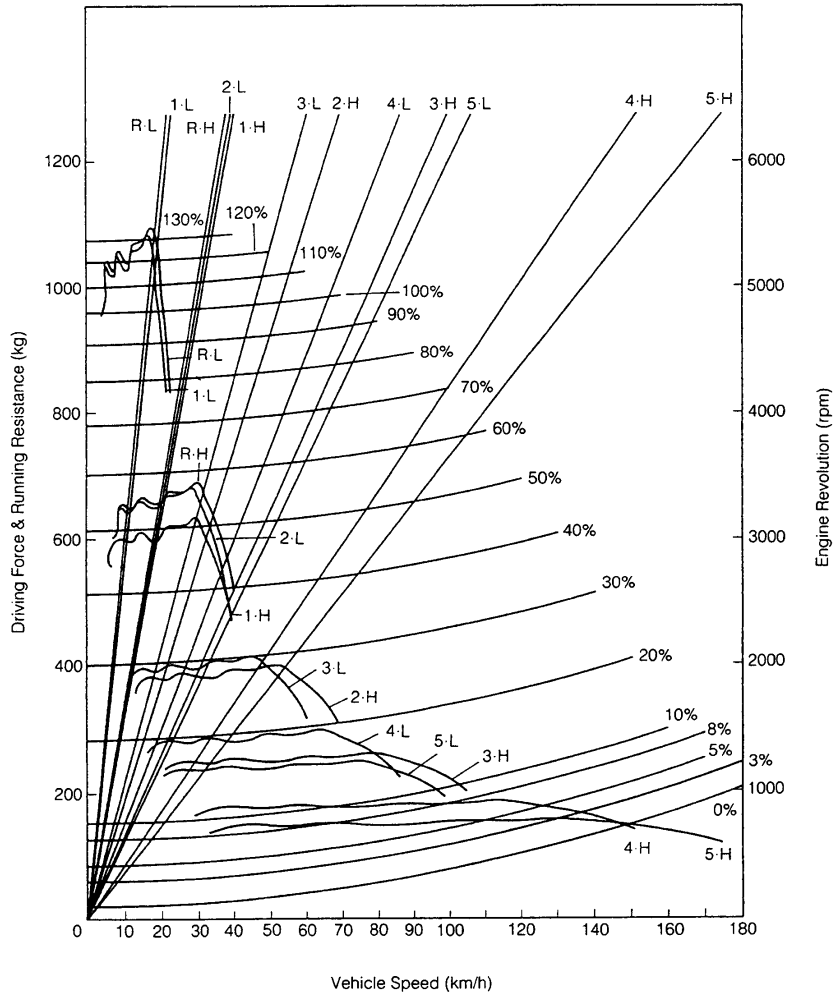

WFES0-GI013

GENERAL INFORMATION

7. SPECIFICATIONS

7-1. PRE-DELIVERY INSPECTION SPECIFICATIONS

Items		Specifications
Tire Inflation Pressure Front/Rear bar	195R15	STD: 1.6/2.1, Full load: 1.6/2.3
	225/70R15 bar	STD: 1.6/2.1, Full load: 1.6/2.3
	195/80R15	STD: 1.6/2.1, Full load: 1.6/2.3
Spare tire inflation pressure		2.3
Wheel nut tightening torque N-m (kgf-m)		88.2 - 117.6 (9 - 12)
Accelerator pedal free play mm		1 - 5
Engine idling speed rpm	HD-C	850 ± 50
	HD-E	850 ± 50
Engine oil	Capacity dm ³	3.8
	Grade	API SE or higher
Transmission oil	Capacity dm ³	1.7
	Grade	API GL-3 or GL-4
	Viscosity	SAE-75W-90
Transfer oil	Capacity dm ³	Part time: 1.4, Full time: 1.7
	Grade	API GL-3 or GL-4
	Viscosity	SAE-75W-90
Differential oil	Capacity dm ³	Front: 0.9 Rear: 1.95
	Grade	API GL-5
	Viscosity	SAE 90 or 80W-90
Brake fluid	Grade	FMVSS116DOT3 or SAE J1703
Brake pedal (While engine is running)	Free travel mm	1 - 3
	Reserve travel mm	Not less than 80
Clutch pedal free travel mm		18 - 27
Parking brake working travel		Should "set" within 4-6 notches when apply 25 kgf by hand
Exhaust emission at tail pipe. (Manufacturer's standard)	Idle CO vol. %	HD-C: 1.5 ± 0.5, HD-E: 0.5 (Max.)
	Idle HC max. ppm	HD-C: 2200, HD-E: 200
	Idle CO ₂ min. %	HD-C: 12.1, HD-E: 14.0

WFE90-GI014

GENERAL INFORMATION

7-2. VEHICLE SPECIFICATIONS

Items		Specifications	
ENGINE	Type	HD-C	Gasoline, Carburetor, 4 Cycle
		HD-E	Gasoline, EFI, 4 Cycle
	Displacement (Bore x Stroke) cm ³		1589 (76 x 87.6 mm)
	Compression ratio		9.5
	Firing order		1 - 3 - 4 - 2
	Ignition timing	HD-C	B.T.D.C. 3° ± 2°/850 ± 50 rpm
		HD-E	B.T.D.C. 3° ± 2°/850 ± 50 rpm
	Valve mechanism		Belt-driven, SOHC
	Valve clearance mm	Intake	0,25 (Hot condition)
		Exhaust	0,33 (Hot condition)
	Spark plug type (Spark gap) mm	CHAMPION	RC9YC4 (1,0 - 1,1)
		NIPPONDENSO	K20PR-U11 (1,0 - 1,1)
		NGK	BKR6E-11 (1.0 - 1.1)
	Coolant capacity dm ³		5,5 (Excluding 1,0 dm ³ in reserve tank)
	Max. output power kW/r.p.m	HD-C	63/6000
		HD-E	70/5700
Max. output torque N-m/r.p.m	HD-C	126/3500	
	HD-E	128/4800	
Recommendation fuel	HD-C	Leaded or Unleaded, Octane 90 or higher (Ron)	
	HD-E	Unleaded, Octane 90 or higher (Ron)	
Fuel tank capacity dm ³		60	
CLUTCH	Type	Dry single plate, diaphragm	
	Operation	Mecahnical	
TRANSMISSION	Type	5-Speed, synchromesh	
	Gear ratio (tooth number)	1st	3,752 (34/23 x 33/13)
		2nd	2,182 (34/23 x 31/21)
		3rd	1,529
		4th	1,000
		5th	0,865 (34/23 x 24/41)
		Reverse	3.942 (34/23 x 23/12 x 32/23)
TRANSFER	Gear ratio	High	1,000
		Low	1,754 (32/33 x 38/21)
DIFFERENTIAL	Gear ratio	5,285 (37/7)	

GENERAL INFORMATION

Items			Specifications		
SUSPENSION	Suspension Type	Front	Double wish bone	Toe-in	4 mm
				Camber	1°
				Caster	2°
		Rear		Rigid	
	Spring	Front	Torsion bar		
		Rear	Leaf spring		
Shock absorber	Front	Double-acting telescopic type			
		Double-acting telescopic type			
STEERING	Type		Ball-nut type		
	Over all gear ratio		24.2, 18.4 (With power steering)		
BRAKES	Type	Front	Disc, (Option: Ventilated rotor)		
			Drum (Leading and Trailing)		
	Service brake system		Vacuum booster, Power-assisted		
	Emergency brake system		Front/Rear split, hydraulic circuits		
	Parking brake system		Mechanical hand operation which applies to rear wheels.		
WHEEL & RIM	Tire size		195R15, 225/70R15, 195/80R15		
	Inflation pressure bar		Front: 1.6, Rear: 2.3		
	Rim	Size	15 x 655		
		Off-set	19 mm		
BULB	Headlamp	W	Candescant	45/40	
			Halogen	60/55	
			Yellow	45/40	
	Front lamp	W	Clearance	5 (White)	
				21 (Amber)	
	Side turn signal lamp	W	5 (Amber)		
	Rear lamp	W	Stop/tail	21/5 (Red)	
			Turn Signal	23 (21: for European)	
			21 (White)		
	License plate lamp	W	5		
Rear fog lamp	W	21			
Interior lamp	W	10			
Luggage room lamp	W	8			

WFE90-GI015

8. SUMMARY OF ENGINE CONSTRUCTION

8-1. AIR INTAKE SYSTEM MODIFICATION (HD-E)

The air intake system consists of the air cleaner, air intake chamber, throttle body, intake manifold, ducts and hoses. It becomes possible to improve the torque around 3200 rpm by employing the air intake chamber.

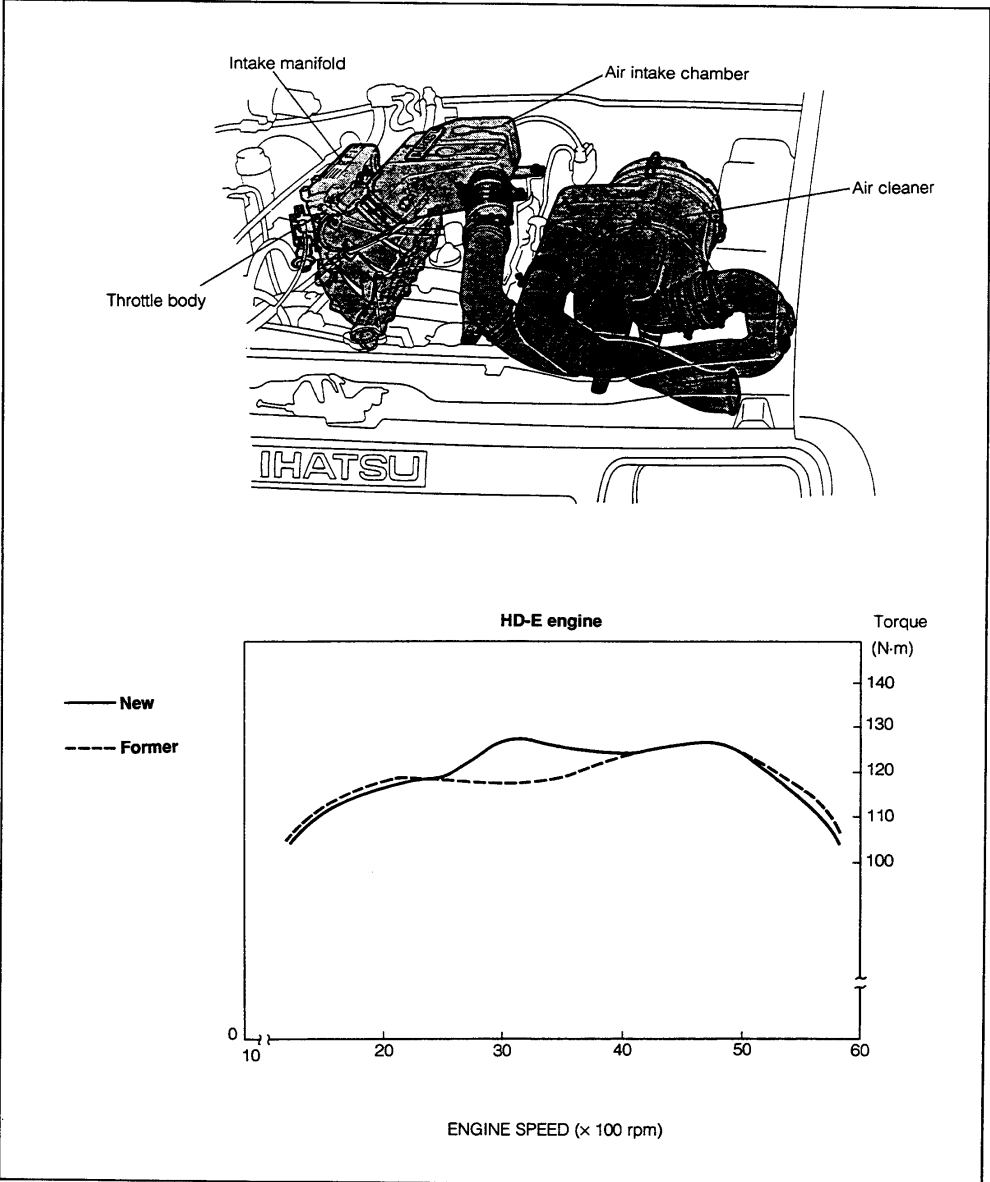

WF90-GI016

GENERAL INFORMATION

8-2. STEREOSCOPIC VIEWS OF HD-E ENGINE

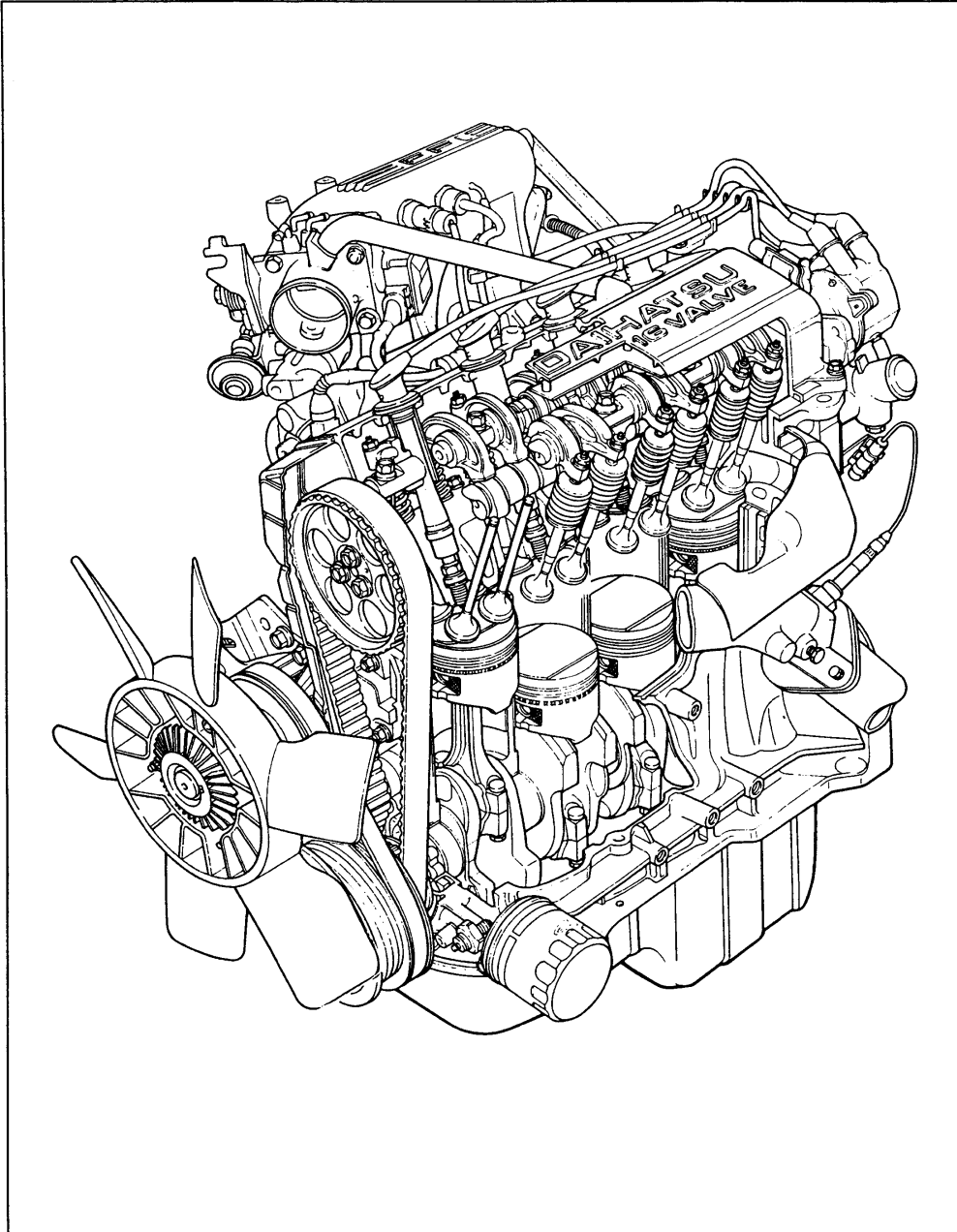

WFES0-G1017

8-3. STEREOSCOPIC VIEWS OF HD-C ENGINE

No modification has been made on Type HD-C engine.

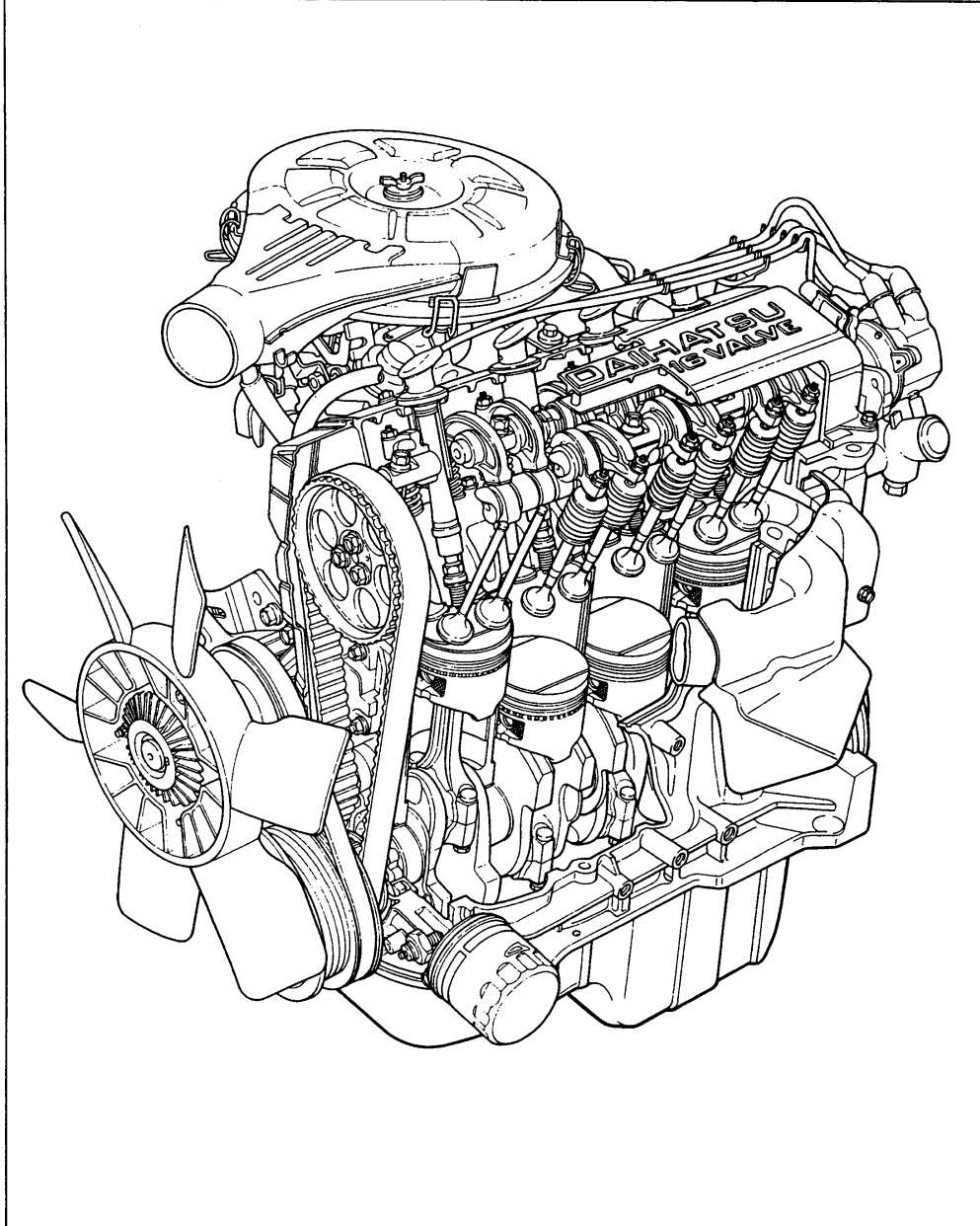

WFES90-GI018

GENERAL INFORMATION

8-4. BLOW-BY GAS RECIRCULATING SYSTEM

Any blow-by gas in the crankcase flows into the cylinder head side after passing through the blow-by gas passage in the cylinder block. Then, the gas travels through an oil separator and will be sucked by the intake manifold negative pressure. Thus, the blow-by gas is reburnt in the combustion chamber.

Furthermore, this recirculation takes place also at the air cleaner in the case of the carburetor specification engine (HD-C); at the upper stream of the throttle body in the case of the EFI specification engine (HD-E). Both engines adopt a closed type blow-by gas recirculating system.

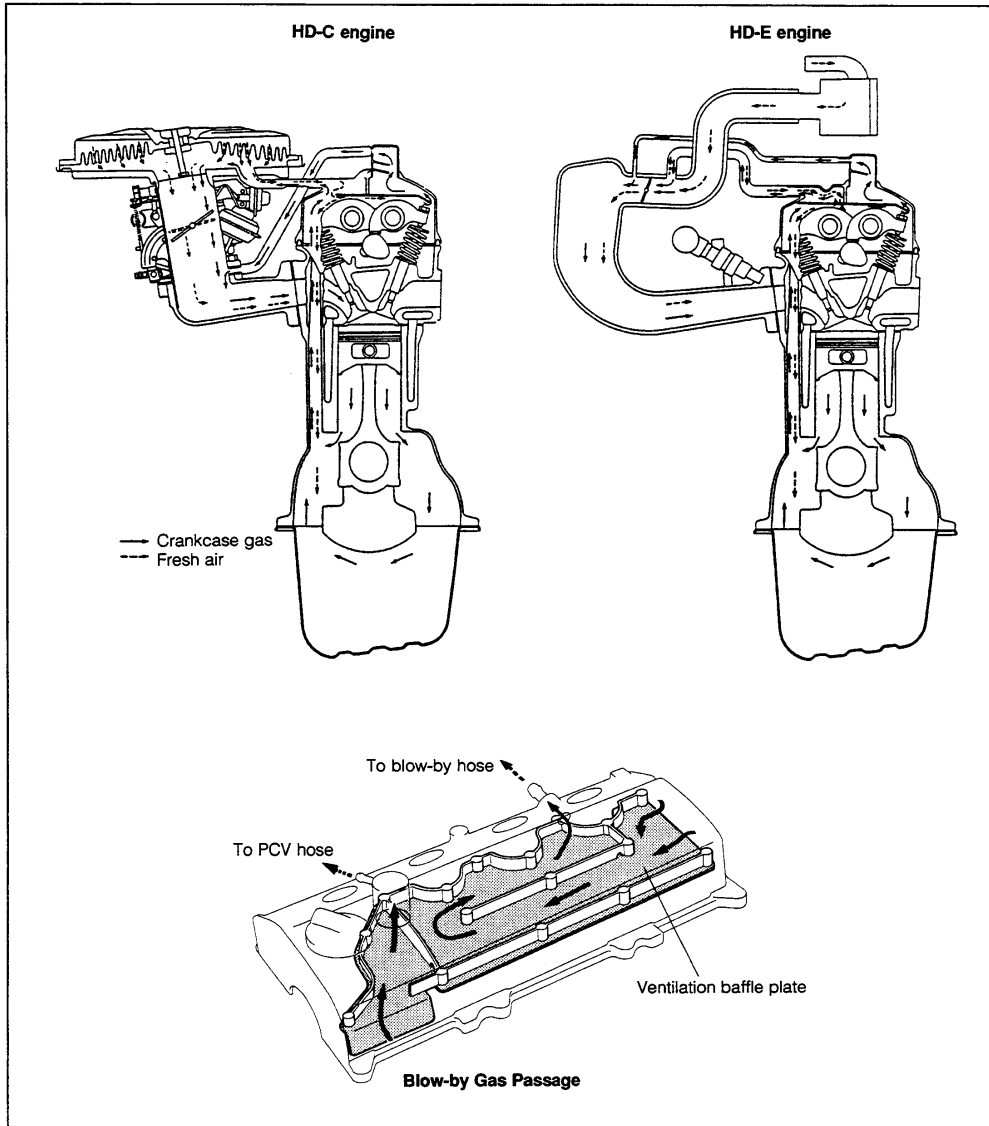

WFE90-G1019

8-5. COOLING SYSTEM

The cooling system is a water-cooled, forced-circulation type. This system employs an inlet water-temperature control bypass method in which a thermostat equipped with a bypass valve is arranged at the water inlet section. The fin pitch of the radiator has been changed.

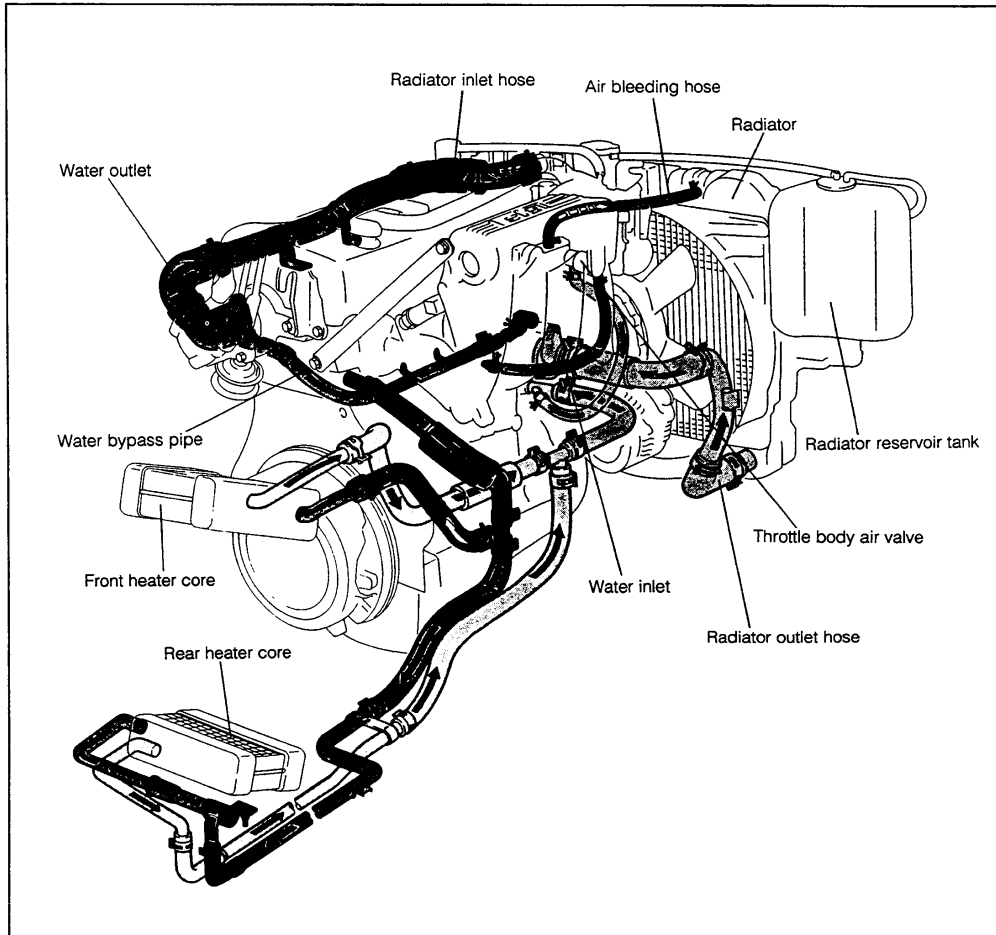

WFE90-G1020

The water pump is a centrifugal type. In order to install the fluid coupling and fan at the flange section, cast iron is used at the body so as to assure the rigidity.

NOTE:

This pump can not be disassembled. Therefore, when replacing the pump during repair works, it is necessary to replace it as the water pump assembly.

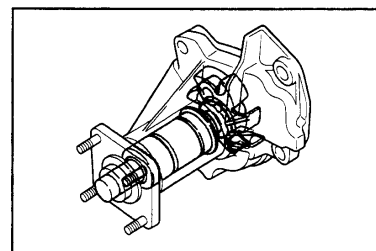

WFE90-G1021

GENERAL INFORMATION

8-6. FUEL SYSTEM

No modification has been made on the fuel system.

On Type HD-E engine, the installation method has been changed to a two-point support so as to reduce the vibration of the fuel pump bracket.

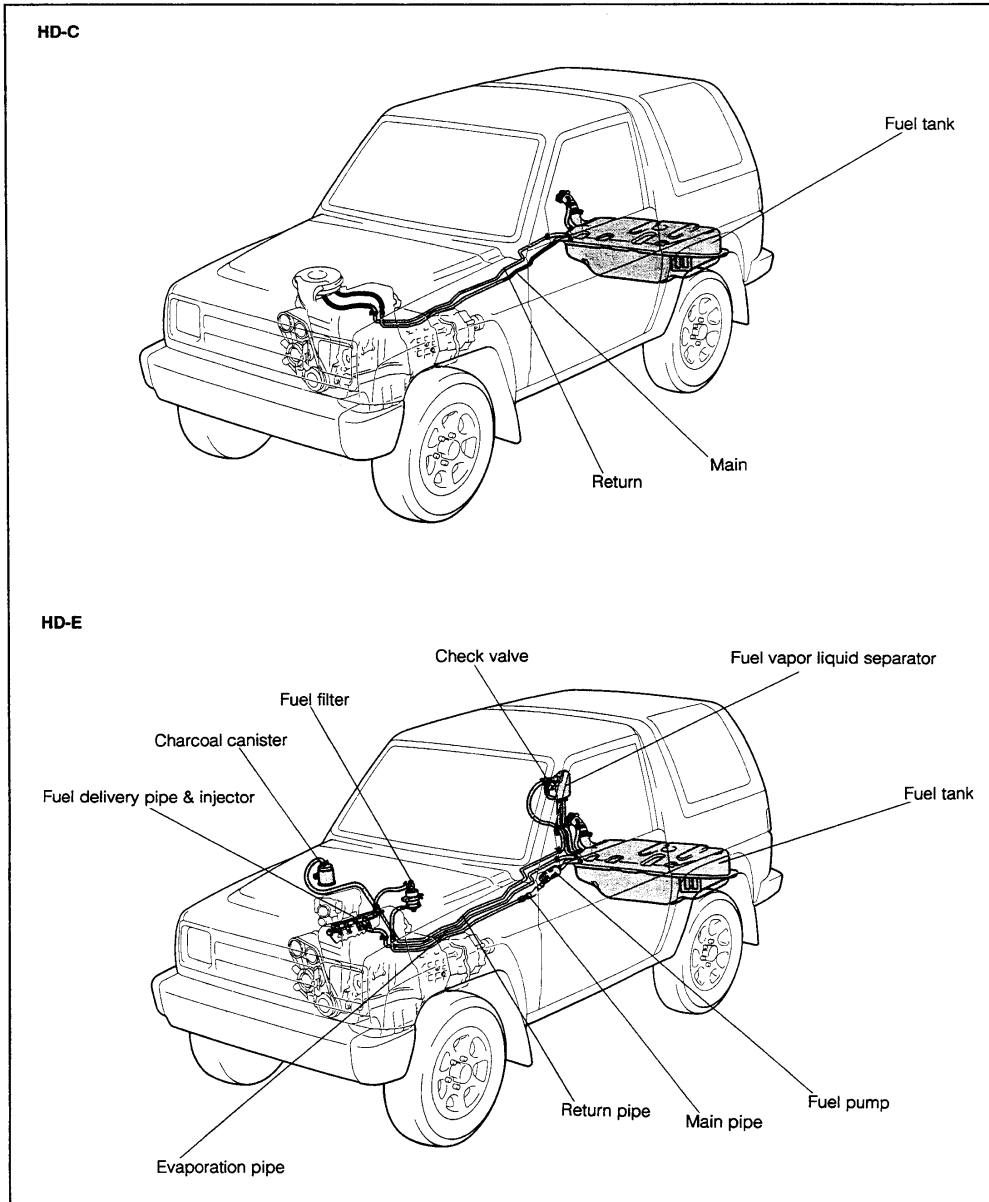

WPE90-GI022

8-7. EMISSION CONTROL SYSTEM

(1) Rubber hose piping (HD-C)

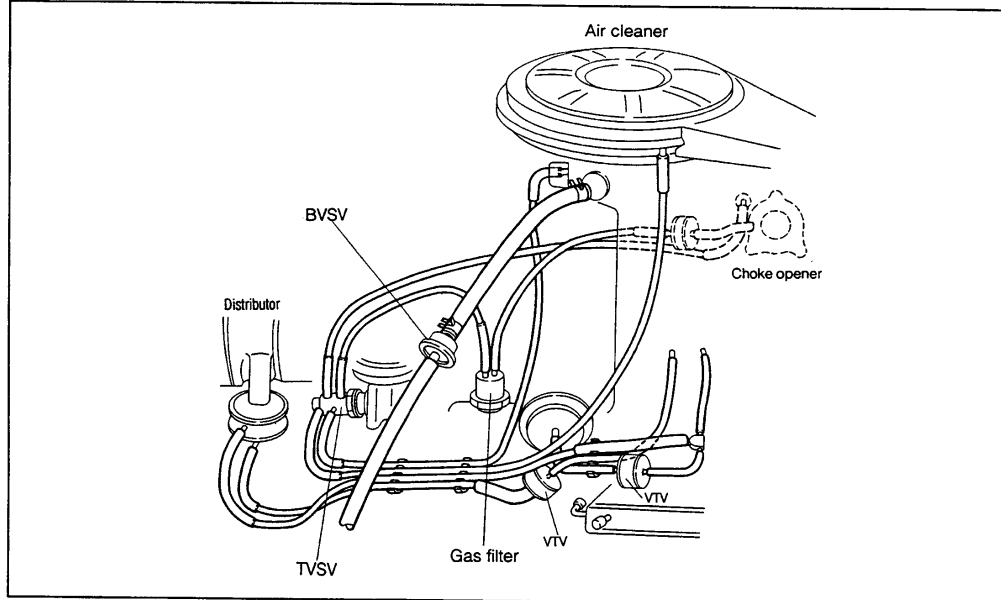

WFE90-GI023

(2) Schematic diagram (HD-C)

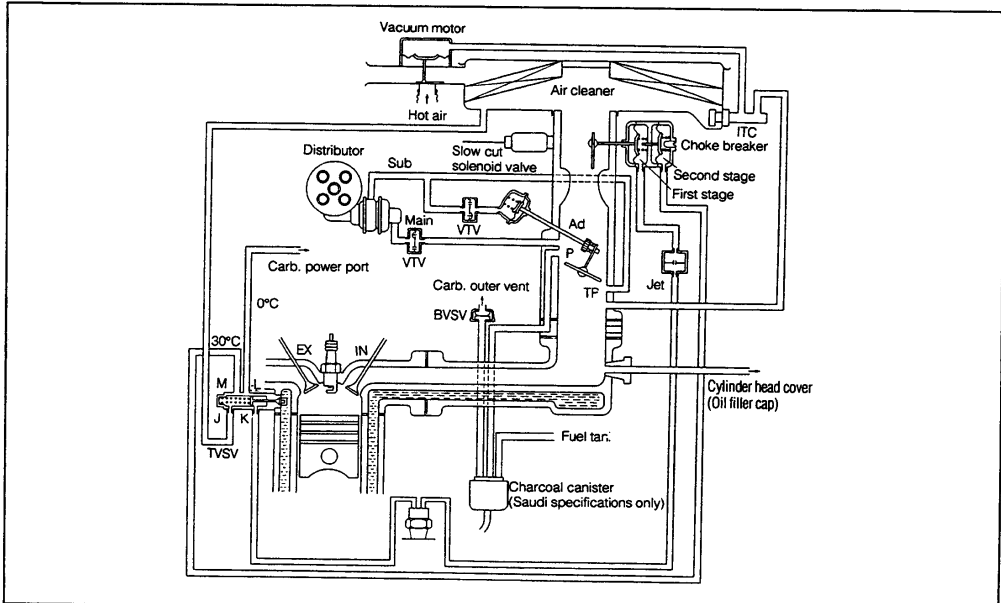

WFE90-GI024

GENERAL INFORMATION

(3) Rubber hose piping (HD-E)

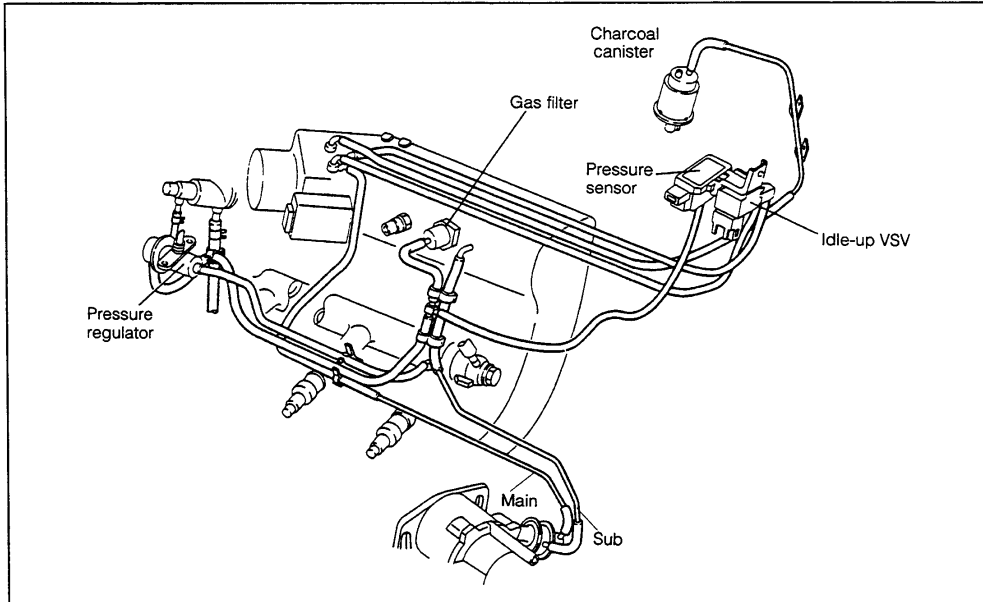

WFE90-GI025

(4) Schematic diagram (HD-E)

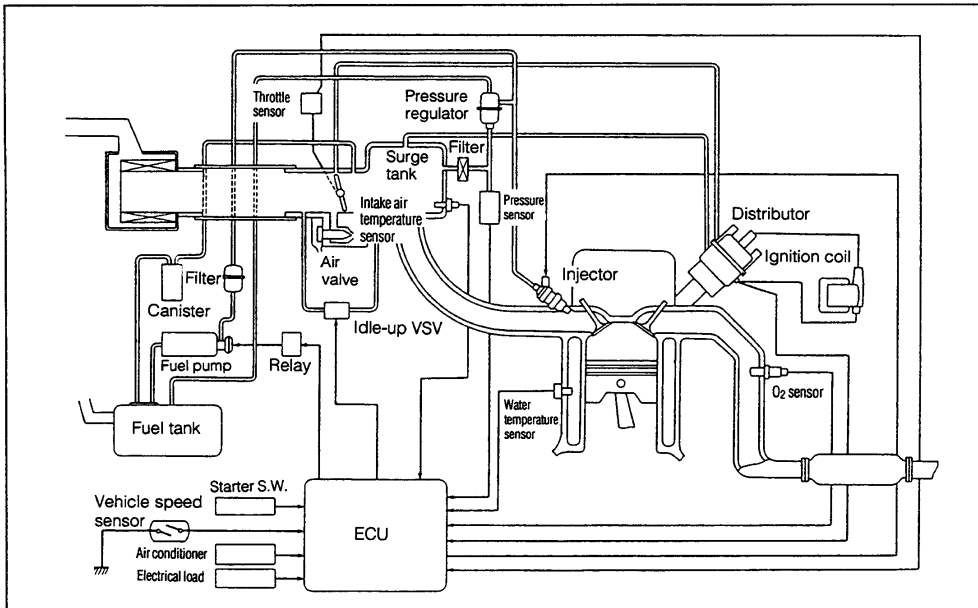

WFE90-GI026

GENERAL INFORMATION

(5) Rubber hose piping (HD-E/US)

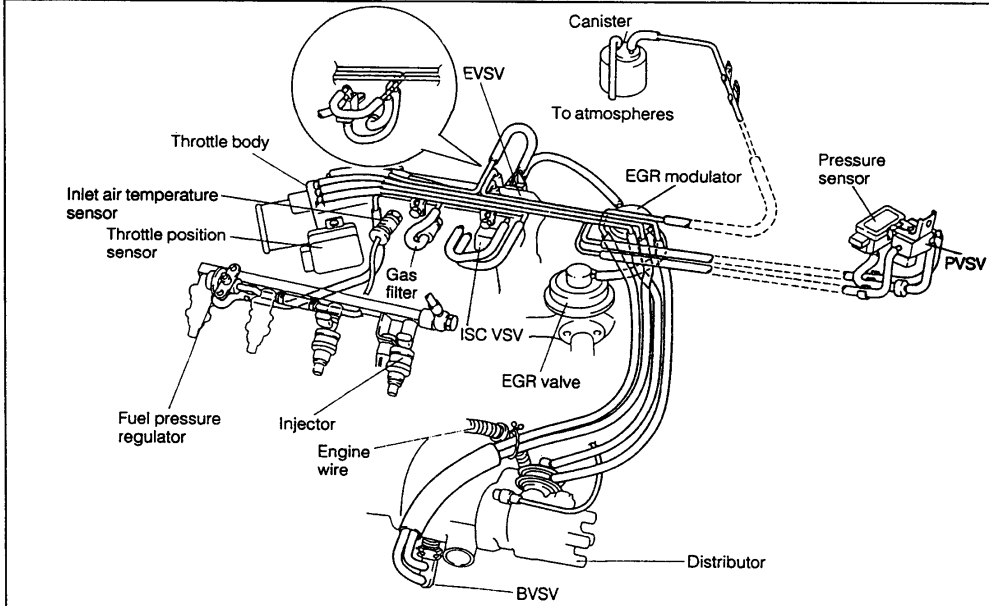

WFE90-GI103

(6) Schematic diagram (HD-E/US)

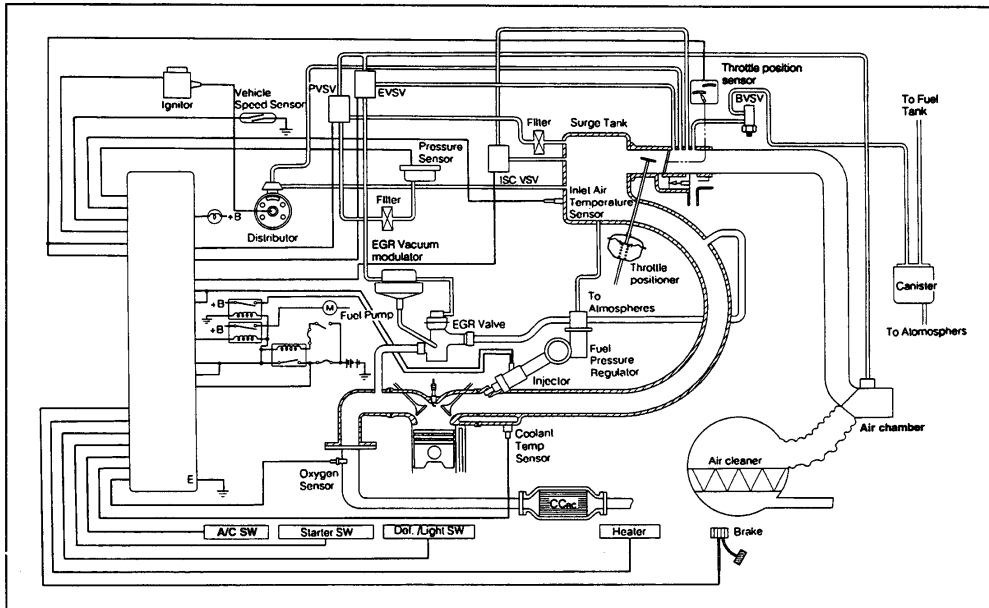

WFE90-GI104

GENERAL INFORMATION

9. SUMMARY OF BODY AND OTHER CONSTRUCTIONS

9-1. BASIC DESIGN

- (1) The F300 was introduced in 1988 as a light 4WD vehicle.
Since its debut, the F300 has been widely praised as a futuristic 4WD offering excellent performance both on-road and off the road.
- (2) The new F300 has been refined to enhance the image as a casual, stylish 4WD city cruiser offering both ruggedness and beauty.



WF90-G1027

GENERAL INFORMATION

9-2. EXTERIOR MODIFICATION

(1) Front grille

The grid-shaped radiator grille has been changed. On the new model, horizontal grille louvres create a rugged front mask. A grey radiator grille is standard. A chrome-plated grille is available as an option. The 16VALVE emblem has been discontinued.

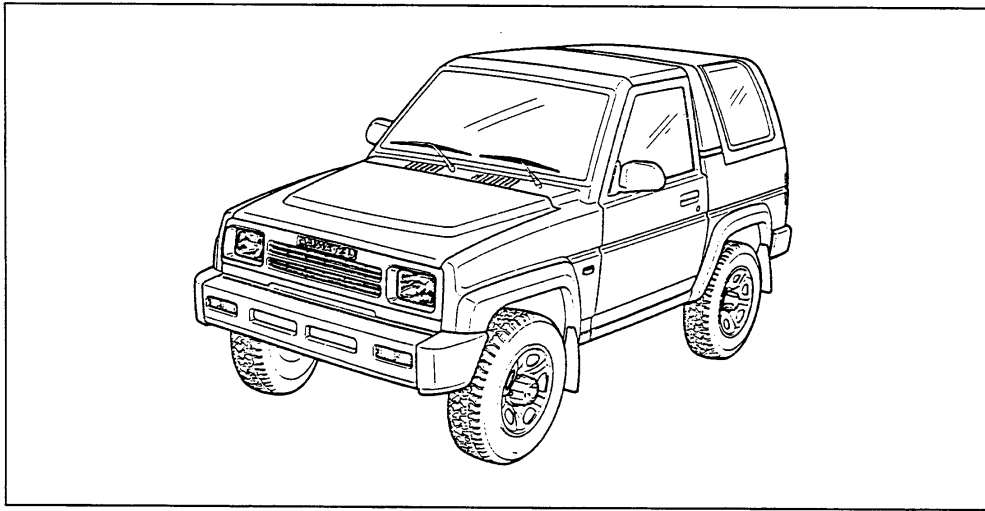
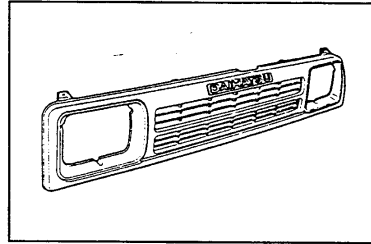

WF90-GI028

(2) Extended wheel arch

To match the rugged 225/70R15 100S wide radial tyres, resin extended wheel arches have been added. (To save transport costs, these are packed together with the vehicles for installation at their destination.)

● : Option

Model	Resin top			Soft top	
	DX	EL	EL-II	DX	EL
Wheel arch colour					
Black	○	●	●	○	○
Body colour	○	○	○	○	○

WF90-GI029

GENERAL INFORMATION

(3) Improved rear visibility

(Only European and Australian markets)

To improve rear visibility, the spare tyre position has been lowered 65 mm, and moved 190 mm to the right. (For the Norwegian market, the spare tyre was only moved to the right so as not to block the license plate.)

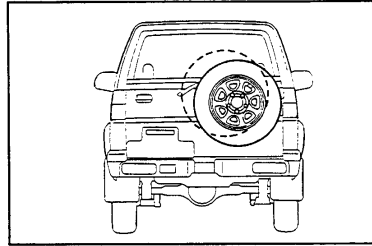

WFEG9-GI030

(4) Rear combination lamps

(Only European and Australian markets)

To improve the visibility of the rear lamps, the tail lamp, brake lamps and side turn signals have been incorporated into a combination lamp and built into the rear bumper. A maroon-coloured lens is provided in the current rear combination lamp position in which only the left-side back-up lamp lights.

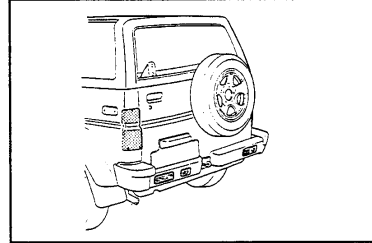

WFEG9-GI031

(5) Improved loadability through the back door (Only European market)

Improved visibility, achieved by building the rear combination lamps into the bumper, allowed adjustment of the back door to allow it to open a full 90°, improving loadability. (Only on models for UK, Denmark, Belgium, Netherlands, Iceland — due to elimination of the full-open stopper)

WFEG9-GI032

(6) New rear fog lamp built in to rear bumper (Only European market)

The rear fog lamp has also been changed to a built-in type for greater visibility.

The fog lamp is mounted on the driver's side on both RHD and LHD models. (Standard on RHD, optional for LHD)

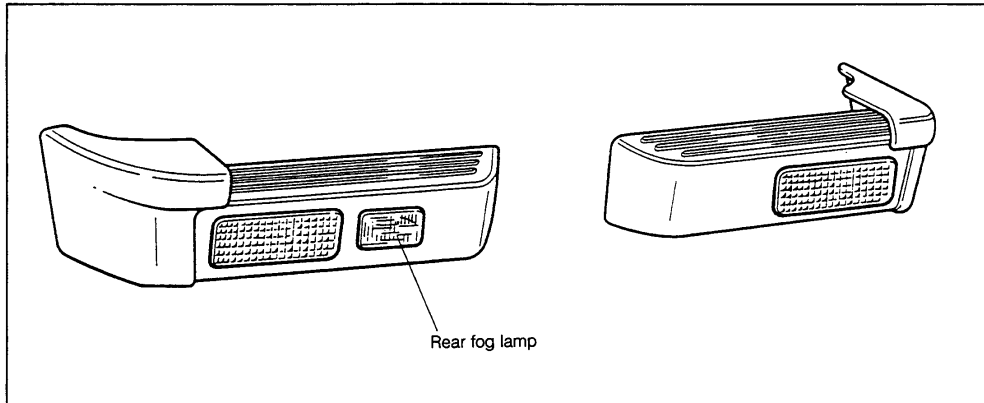

WFEG9-GI033