

VEHICLE SPEED SENSORS AND TORQUE CONVERTER TURBINE SPEED SENSOR

Automatic Transmission

6. Vehicle Speed Sensors and Torque Converter Turbine Speed Sensor

SS10586

A: REMOVAL

SS10586A18

- 1) Extract the torque converter clutch assembly.
<Ref. to AT-34 REMOVAL, Torque Converter Clutch Assembly.>

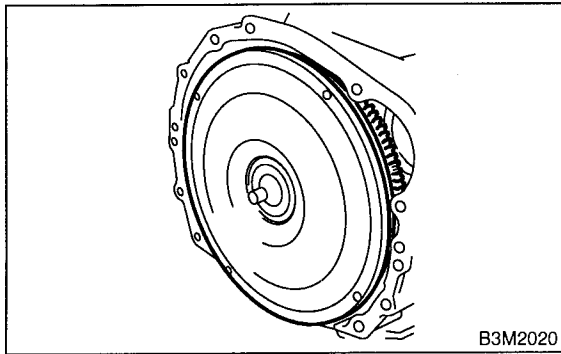

- 2) Disconnect transmission harness connector from stay.

NOTE:

Lift-up lever behind connector and disconnect it from stay.

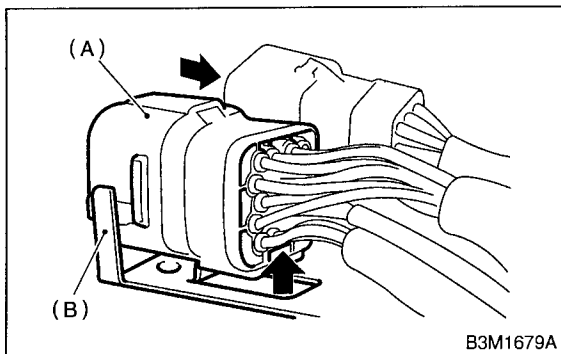

- (A) Transmission harness
- (B) Stay

- 3) Disconnect inhibitor switch connector from stay.
- 4) Disconnect the air breather hoses. <Ref. to AT-27 REMOVAL, Air Breather Hose.>
- 5) Wrap vinyl tape around the nipple attached to the air breather hose.
- 6) Remove pitching stopper bracket.
- 7) Remove the oil charger pipe. <Ref. to AT-28 REMOVAL, Oil Charger Pipe.>
- 8) Remove the oil cooler pipes. <Ref. to AT-29 REMOVAL, Oil Cooler Pipes.>
- 9) Insert a shop cloth into the installation holes of oil charger pipe and oil cooler pipe.

- 10) Remove rear vehicle speed sensor.

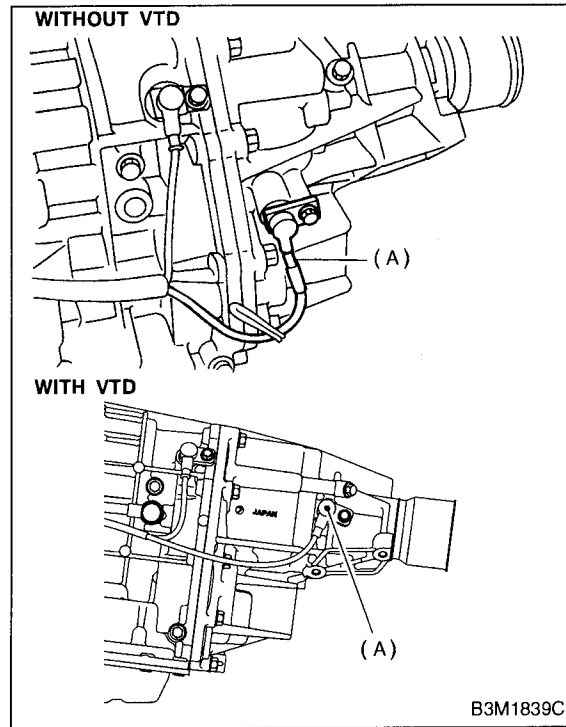

- (A) Rear vehicle speed sensor

- 11) Remove front vehicle speed sensor and torque converter turbine speed sensor.

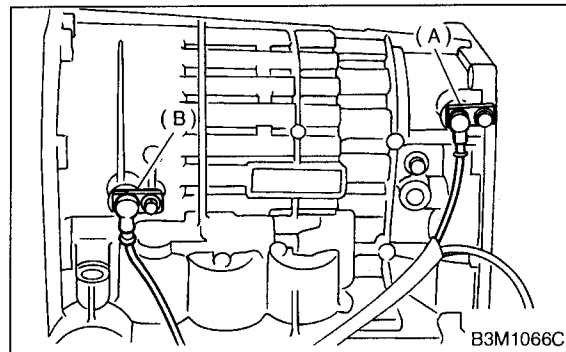

- (A) Front vehicle speed sensor
- (B) Torque converter turbine speed sensor

- 12) Remove the inhibitor switch.

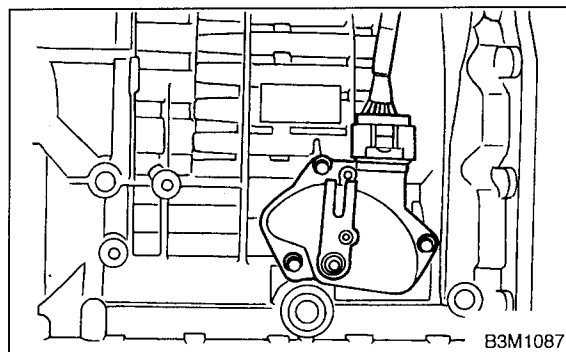

13) Prepare a block of wood. Turn over the transmission case and make it secure with the block of wood.

NOTE:

Turn over in the direction the inhibitor switch was installed.

14) Remove the oil pan.

NOTE:

Use a scraper to remove oil pan.

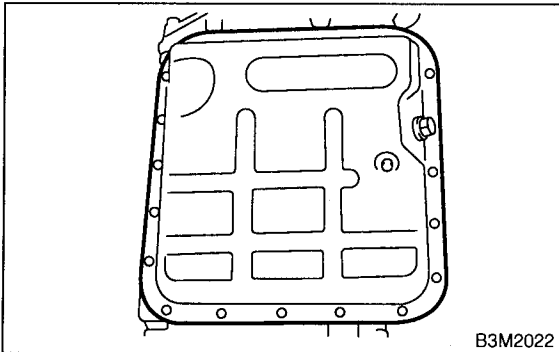

15) Disconnect the harness connectors for the solenoids, duty solenoids, ATF temperature sensor and the ground cord.

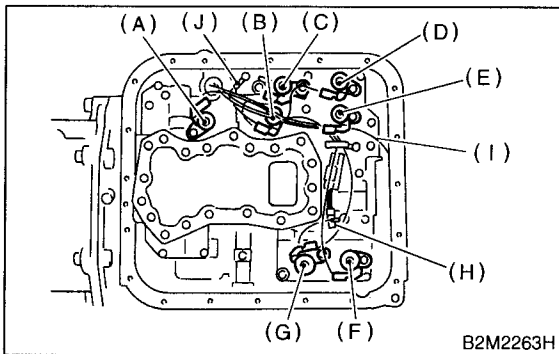

- (A) Lock-up duty solenoid (Blue)
- (B) Low clutch timing solenoid (Gray)
- (C) Line pressure duty solenoid (Red)
- (D) Shift solenoid 2 (Yellow)
- (E) Shift solenoid 1 (Green)
- (F) 2-4 brake timing solenoid (Black)
- (G) 2-4 brake duty solenoid (Red)
- (H) ATF temperature sensor
- (I) Transfer duty solenoid (Brown)
- (J) Transmission ground

16) Remove transmission harness.

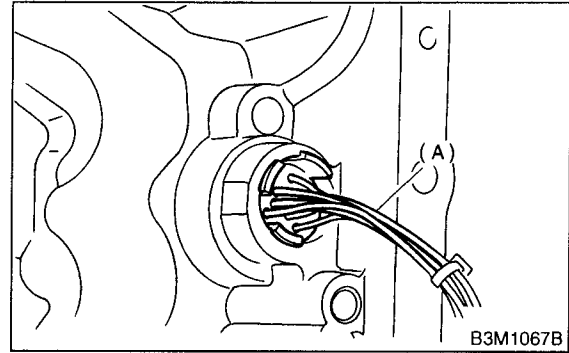

(A) Transmission harness

B: INSTALLATION S510586A11

1) Install and route the transmission harness.

CAUTION:

Be careful not to damage the harness.

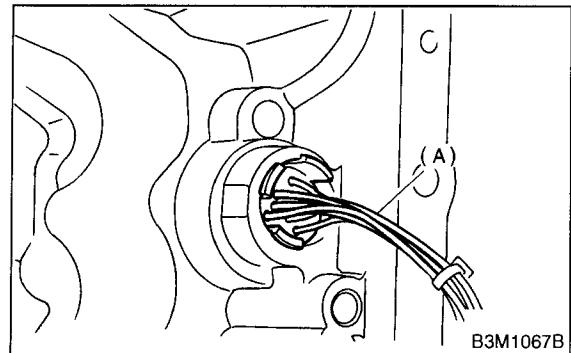

(A) Transmission harness

2) Connect all connectors.

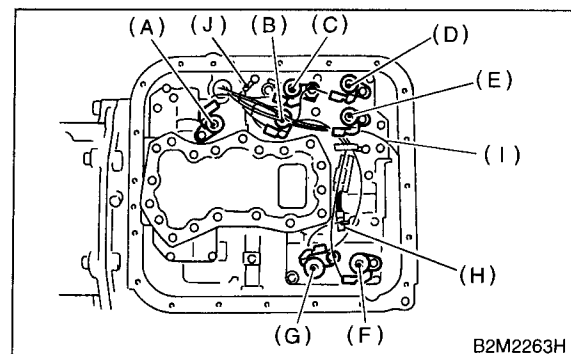

- (A) Lock-up duty solenoid (Blue)
- (B) Low clutch timing solenoid (Gray)
- (C) Line pressure duty solenoid (Red)
- (D) Shift solenoid 2 (Yellow)
- (E) Shift solenoid 1 (Green)
- (F) 2-4 brake timing solenoid (Black)
- (G) 2-4 brake duty solenoid (Red)
- (H) ATF temperature sensor
- (I) Transfer duty solenoid (Brown)
- (J) Transmission ground

VEHICLE SPEED SENSORS AND TORQUE CONVERTER TURBINE SPEED SENSOR

Automatic Transmission

3) Apply proper amount of liquid gasket to the entire oil pan mating surface.

Liquid gasket
THREE BOND 1217B

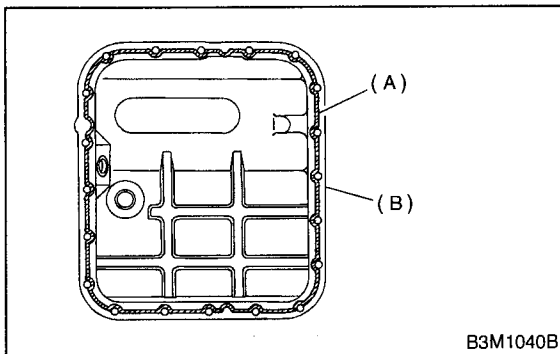

- (A) THREE BOND (Part No. 1217B)
- (B) Oil pan

4) Install the oil pan to the transmission case assembly, and secure with 20 bolts.

NOTE:
Tighten the bolts evenly.

Tightening torque:
4.9 N·m (0.50 kgf-m, 3.6 ft-lb)

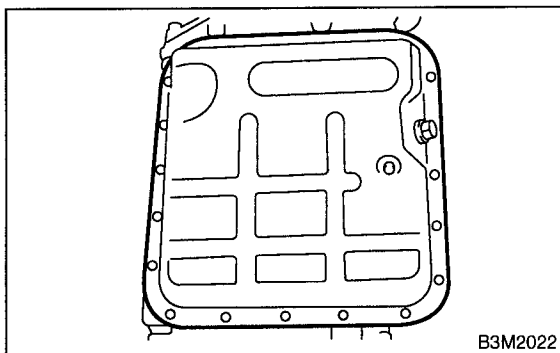

5) Turn over the transmission case to its original position.

6) Install torque converter turbine speed sensor and front vehicle speed sensor.

Tightening torque:
7 N·m (0.7 kgf-m, 5.1 ft-lb)

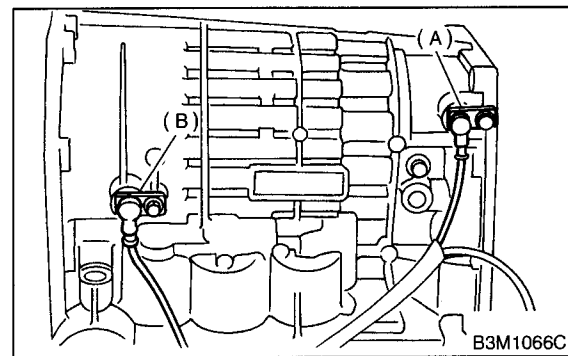

- (A) Front vehicle speed sensor
- (B) Torque converter turbine speed sensor

7) Install the rear vehicle speed sensor.

Tightening torque:
7 N·m (0.7 kgf-m, 5.1 ft-lb)

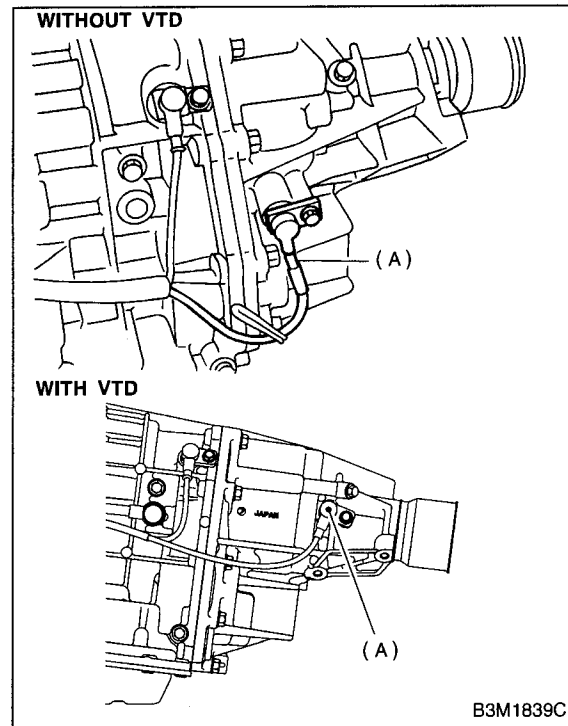

- (A) Rear vehicle speed sensor

8) Remove the vinyl tape, and then install air breather hose. <Ref. to AT-27 INSTALLATION, Air Breather Hose.>

9) Install the oil cooler pipes. <Ref. to AT-29 INSTALLATION, Oil Cooler Pipes.>

10) Install the oil charger pipe. <Ref. to AT-28 INSTALLATION, Oil Charger Pipes.>

11) Install the torque converter clutch assembly. <Ref. to AT-34 INSTALLATION, Torque Converter Clutch Assembly.>

12) Install inhibitor switch and adjust the inhibitor switch by referring to Supplement AT section.

13) Install inhibitor switch connector and transmission connector to the stay.

14) Install pitching stopper bracket.

VEHICLE SPEED SENSORS AND TORQUE CONVERTER TURBINE SPEED SENSOR

Automatic Transmission

Tightening torque:

41 N·m (4.2 kgf-m, 30.4 ft-lb)