

STANDARD AUDIO TESTS

BY

CLIFFORD SCHROCK

ACKNOWLEDGEMENTS

The author would like to thank Linley Gumm and Gordon Long for their excellent technical assistance in the preparation of this paper. In addition, I would like to thank Joyce Lekas for her editorial assistance and Jeanne Galick for the illustrations and layout.

CONTENTS

PRELIMINARY INFORMATION

Test Setups _____	page 2
Input- Output Load Matching _____	page 3

TESTS

Power Output _____	page 4
Frequency Response _____	page 5
Harmonic Distortion _____	page 7
Intermodulation Distortion _____	page 9
Distortion vs Output _____	page 11
Power Bandwidth _____	page 11
Damping Factor _____	page 12
Signal to Noise Ratio _____	page 12
Square Wave Response _____	page 15
Crosstalk _____	page 16
Sensitivity _____	page 16
Transient Intermodulation Distortion _____	page 17
SERVICING HINTS _____	page 19

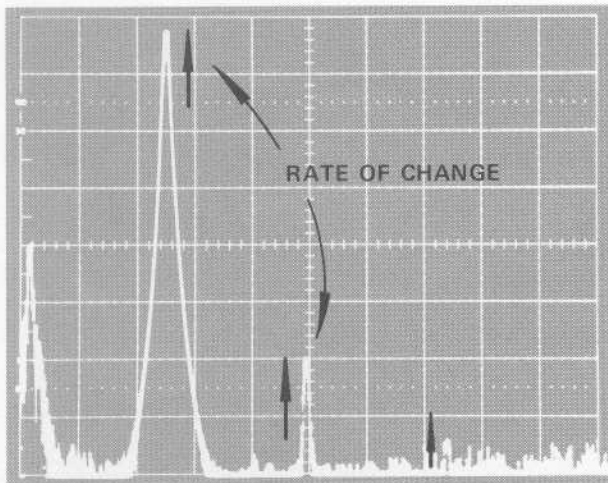

Figure 10 Distortion Crossover Point for Measuring Power

5. For the new FTC test,^{3,4} all channels of a multi-channel (stereo) amplifier should be driven to the maximum power point before power is measured.

6. Power is determined by assuming the full screen display to be the value of the load-matching combination. Switch to the 2 dB/DIV mode and note the number of dB down from the top graticule line, as shown in Figure 11. This is the power output in dB below the full screen display and can be converted directly to watts.

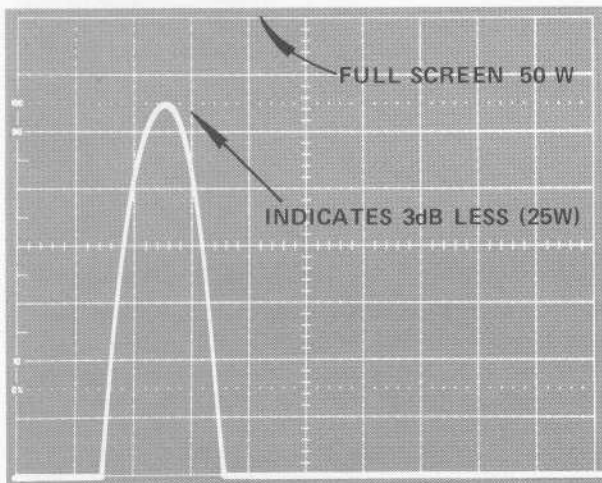

Figure 11 Calculating Power Output

Notes:

1. An alternative procedure for demonstrating maximum undistorted power is to simultaneously apply the 1 kHz tone through a plug-in vertical amplifier in the compartment next to the 5L4N and display the time domain sine wave on the scope. Increase the tone level until the sine wave visibly clips, as shown in Figure 12. The power level in dBV or dBm is then read on the spectrum analyzer display.

2. To satisfy the FTC¹ requirements, the rated power must be obtainable at all frequencies within the rated power band (width) without exceeding the total rated maximum harmonic distortion. Procedures on Power Bandwidth and

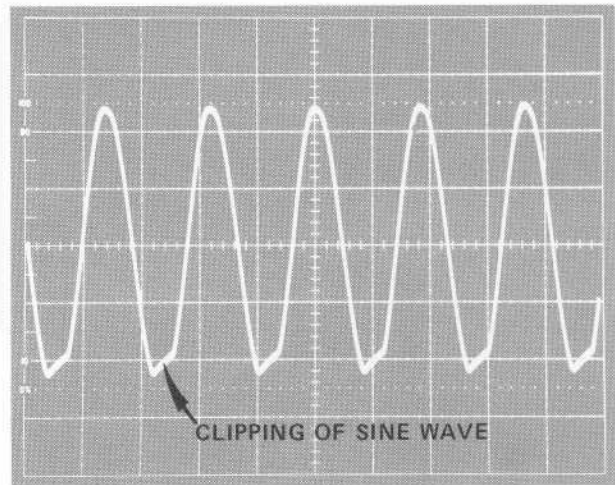

Figure 12 Visible Clipping of sine wave

Harmonic Distortion are contained in this application note and should be followed to satisfy the entire FTC regulation.

Frequency Response

Frequency Response is a measure of the amplifier's ability to pass a wide range of frequencies in the audio spectrum. Ideally, one would strive to achieve a flat response; that is, all frequencies would pass through an amplifier with equal amplification. A Hi-Fi amplifier may have controls to modify the response. These may include tone controls (bass and treble), rumble and hum filters (low frequency rolloff), scratch filters (high frequency rolloff), and a variety of tailoring devices such as the RIAA, FM de-emphasis, and tape head equalization filters. The frequency response test should provide response information of the amplifier in the flat position and should also represent the limits and interaction of the tone controls and filters.

Response of a modern Hi-Fi system is generally measured from below 20 Hz to well beyond the 15 kHz audible limit. It is measured in dB of deviation across the audio spectrum.

The 5L4N Low Frequency Analyzer is ideally suited to frequency response testing since it has a self contained tracking generator and a log sweep 20 Hz to 20 kHz mode. An amplifier can be swept under a variety of different conditions in a matter of seconds, eliminating the need for tedious measurements and point to point plots. Multiple traces of conditions can be built up either on film or on a storage oscilloscope to obtain one picture of the complete response performance of an audio device.

The rated frequency response³ is the frequency range over which the amplitude response does not vary more than plus or minus 3dB from the amplitude at 1000 Hz.

3. EIA Standard Methods of Measurement for Audio Amplifiers Used in Home Equipment, RS-234-C (1971).

4. Larry Klein, "Amplifier Power-Output Ratings: A New FTC Trade Regulation Rule," Stereo Review, Vol. 35 No. 5, Page 79, November 1974.

SERVICING HINTS

The combination Low Frequency Spectrum Analyzer-Oscilloscope offers tremendous flexibility to permit rapid servicing of high quality Hi-Fi and stereo equipment. An oscilloscope probe can be connected directly to the front panel of the 5L4N making it easy to pinpoint problem areas.

While it is impossible to list all the steps and techniques one might use, the following are some of the things we came across while preparing this applications brochure.

A. BIAS VOLTAGE ADJUSTMENT

The adjustment of bias voltage on the output stage is traditionally done with a voltmeter or a distortion analyzer. The Low Frequency Analyzer can be connected to an amplifier and using a single tone (like 1 kHz) the bias can be quickly set for minimum harmonic amplitude. Then the output power can be reduced and the low level crossover distortion that sometimes occurs can be double checked.

B. INAUDIBLE FREQUENCIES

Sometimes a Hi-Fi system doesn't seem to perform correctly and the problem can be traced to overloading or distortion due to INAUDIBLE frequencies being passed by the amplifier.

The more common causes of these frequencies are inaccurate adjustment of the stereo traps (letting 19 and 38 kHz into the audio channel); tape recorder bias traps improperly adjusted; improper bypassing of inputs letting radio frequency energy into the amplifier; and sometimes an amplifier will just oscillate all by itself.

By using the 10 kHz/DIV MODE of the analyzer routinely when checking an amplifier, these kinds of problems will be immediately visible. Figure 54.

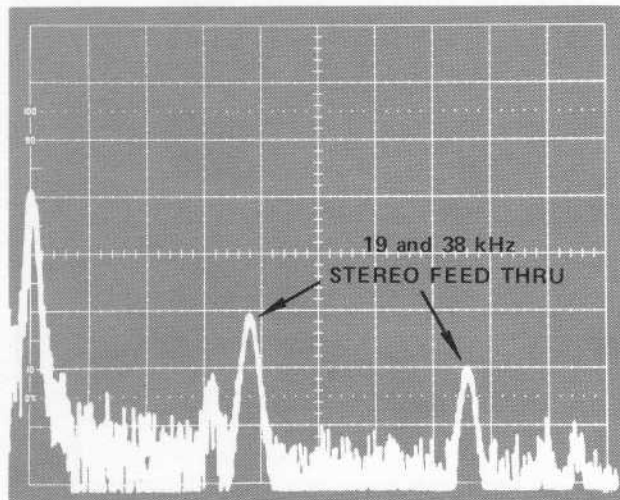

Figure 54 Misadjustment of stereo traps in Hi-Fi receiver

C. STAGE BY STAGE GAIN CHECK

Stage by Stage Gain Check are often used to find the source of a weak or distorted channel in an amplifier system. A modification of the stage by stage check can be performed with the Low Frequency Spectrum Analyzer using the tracking generator output. Insert the tracking generator into an amplifier input, and using a X10 oscilloscope probe, begin at the input stages of the amplifier and monitor the input and output of each stage.

Channels can be compared to each other or gain and response can be checked against the manufacturers' recommendations. Certain problems will be immediately obvious if they exist.

1. Gain differences will show up on the display.

2. Low frequency rolloff will indicate such things as defective stage coupling or output coupling capacitors.

3. High frequency rolloff could indicate defective emitter bypass capacitors or other associated problems.

The test can then be repeated with no signal on the amplifier input, watching the noise floor. A high noise floor rise between stages is characteristic of a defective or hot component.

Finally, using a 1 kHz tone, a stage by stage check can be performed while watching the 2nd and 3rd harmonics for signs of a stage with higher than normal distortion. Typically, the output stage should contribute most of the distortion in an amplifying system.

D. STYLUS PRESSURE ADJUSTMENTS

Phono cartridge weight adjustments are often one of the least understood areas of Hi-Fi. The manufacture attempts to recommend the lowest stylus pressure that produces minimum distortion. By using a continuous tone test record, and starting with a new stylus, the pressure is increased progressively until the lowest distortion (2nd and 3rd harmonics) of the tone are noted. This test can be easily duplicated in the shop using the low frequency analyzer.

A little imagination, and a low frequency spectrum analyzer can go a long way toward taking the mystery out of Hi-Fi repairs. Other equipment such as tape recorders, speakers, and electronic instruments (like organs) can be analyzed. Complete PA systems used in auditoriums can be swept and analyzed, or the acoustics and noise levels of an auditorium could be checked.

This pamphlet only covers one small application area for the low frequency analyzer. We hope that you will have an opportunity to experiment with our applications and expand them to fit your individual needs.

SPECIFICATIONS -- 5L4N INTERIM

CW Sensitivity (Signal level + noise = 2X noise)

The following characteristics are applicable with the input internally terminated or with a 600 Ω or less source impedance:

Display Mode	Resolution Bandwidth	
	3 kHz	10 Hz
dBV	-123 dBV	-147 dBV
dBm 50 Ω	-110 dBm	-134 dBm
dBm 600 Ω	-121 dBm	-145 dBm
LIN	680 nV	45 nV

With the input open, displayed noise is the thermal noise of the input 1 M Ω /50 pF impedance.

Intermodulation Distortion (with the input signal level equal to or less than the reference level):

Third order products are down 70 dB or more from two -10 dBm/dBV signals, within any frequency span and 75 dB or more down from two -20 dBm/dBV signals, within any frequency span.

Spurious Signals from Internal Sources (Residual Response) with TRKG GEN and 5 kHz FREQ COMB OFF and the input terminated in an impedance of 600 Ω or less are:

Equal to or less than -130 dBm/dBV referred to the input

Line related spurii are less than -120 dBm/dBV

With high input impedance and single-ended, the high voltage oscillator in some mainframes causes spurii at 30 kHz and harmonics \leq 100 dBV.

SPECIFICATIONS -- 5L4N INTERIM

The zero (start) spur is less than -80 dBV or four divisions (10 dB/DIV) with -10 dBV to -40 dBV reference level range.

Input Characteristics

The INPUT connector is a floating two-conductor BNC connector that provides either a differential or single-ended input. Input selection is provided by a switch that grounds the outer conductor of the connector when it is in the SINGLE ENDED position. An accessory adapter (floating BNC to dual BNC) provides full shielding of the input signal leads.

NOTE

When operating in the DIFFERENTIAL mode, the INPUT connector is floating. The outer conductor therefore equals the voltage level of the external source. Since the external source voltage may be some high potential, the outer conductor voltage is clamped at ± 10 V for safety.

Selectable input impedance provides; either high Z of $1\text{ M}\Omega/50\text{ pF}$, or internally terminated impedances of $600\ \Omega$ or $50\ \Omega \pm 2\%$.

Differential Input Characteristics

Common-mode signal range: ± 10 volt

OPERATIONAL/PERFORMANCE CHECK -- 5L4N INTERIM

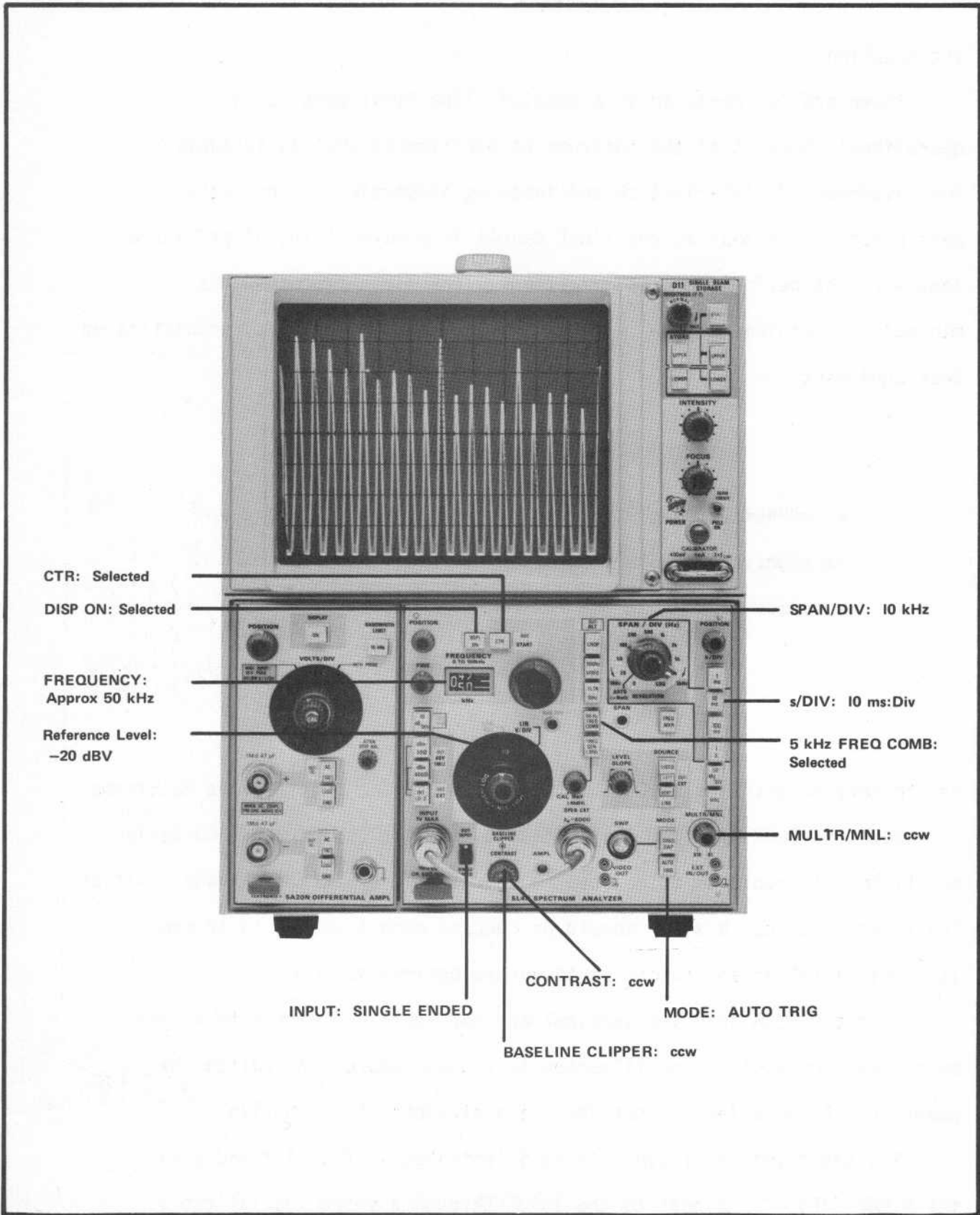

Fig. 3-1. Front panel control and selector positions for the initial operational check and front panel calibration.

OPERATIONAL/PERFORMANCE CHECK -- 5L4N INTERIM

With the display mode in 2 dB/Div (LOG), adjust the mainframe Intensity and Focus controls for the best display definition (it may be necessary to select a slower sweep rate to adjust Focus and Intensity); set the baseline of the display at the bottom graticule line and center the display with the horizontal POSITION control. Select the STORE mode if the mainframe has store capabilities.

Depress the 10 dB/DIV button.
Adjust the RESOLUTION for the best marker definition.
Display should now resemble the illustration shown in Fig. 3-2A.

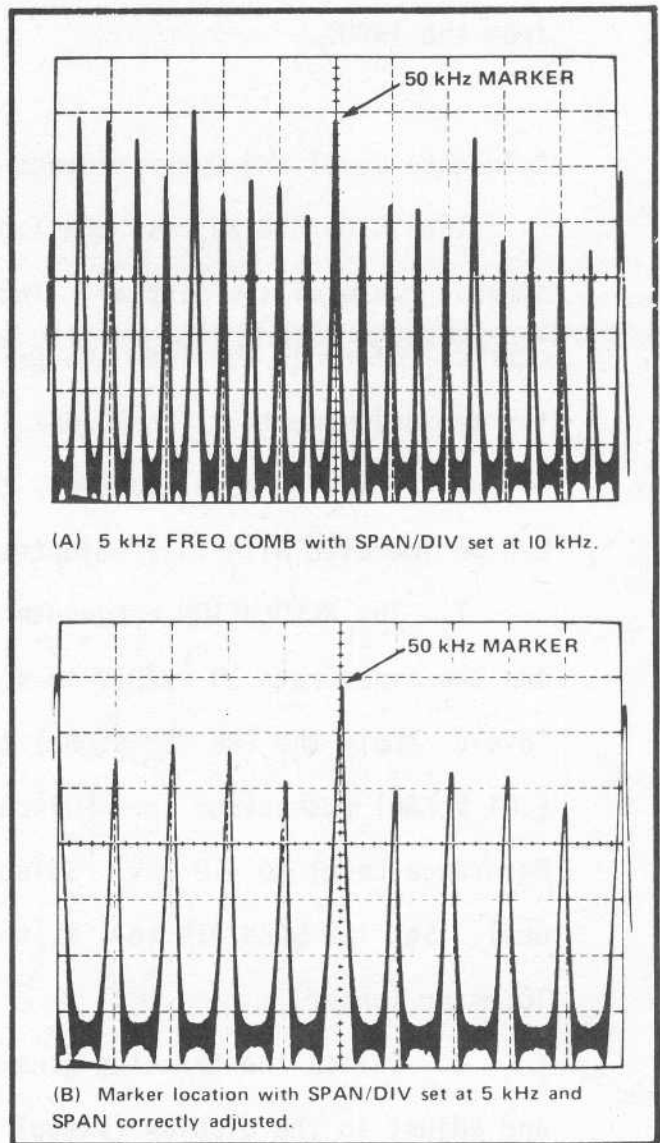
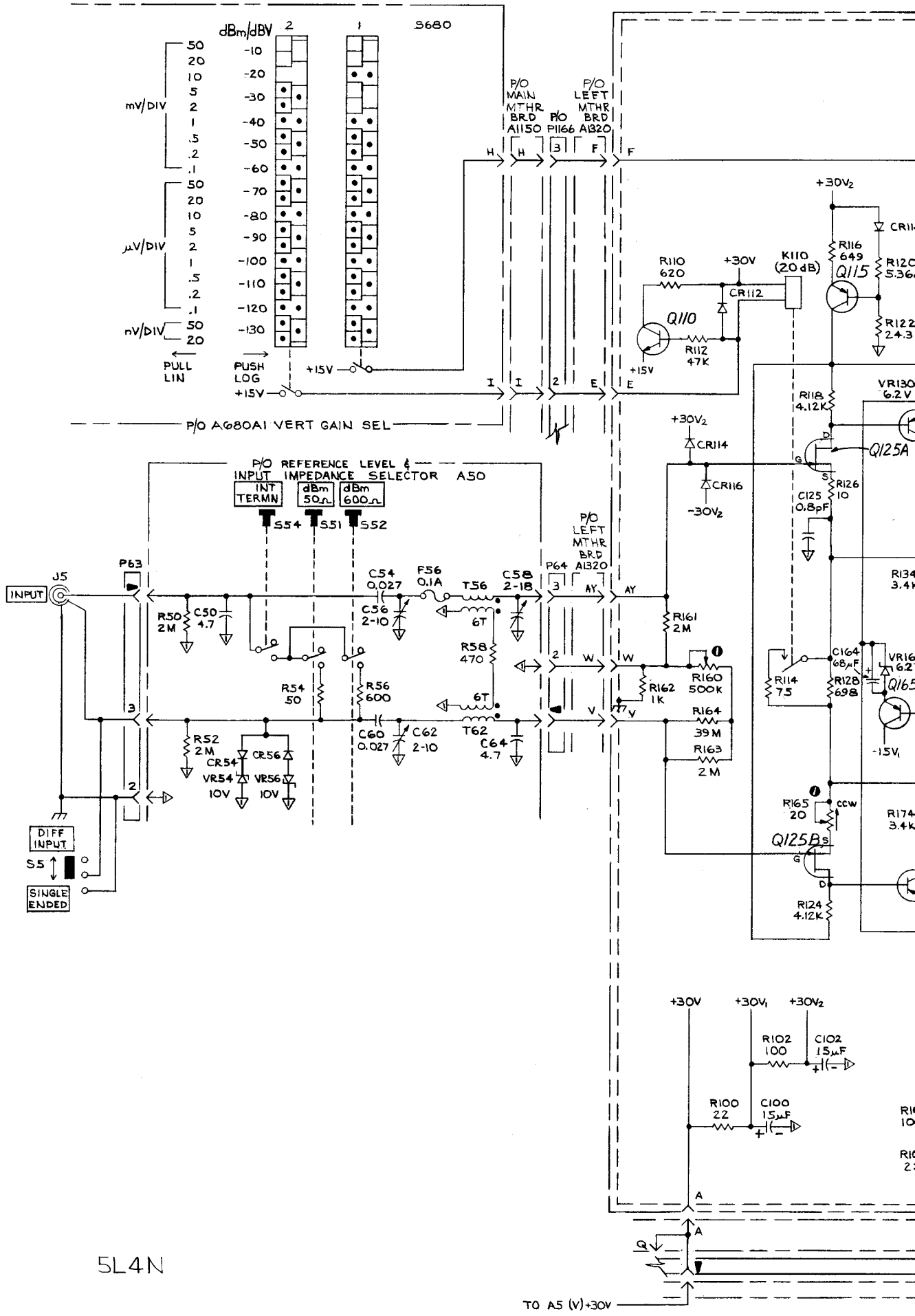

Fig. 3-2. Freq Span calibration.

Electrical Parts List—5L4N

Ckt No.	Tektronix Part No.	Serial/Model No.		Name & Description	Mfr Code	Mfr Part Number
		Eff	Dscont			
R492	321-0371-00			RES.,FXD,FILM:71.5K OHM,1%,0.125W	75042	CEAT0-7152F
R493	321-0154-00			RES.,FXD,FILM:392 OHM,1%,0.125W	75042	CEAT0-3920F
R494	321-0251-00			RES.,FXD,FILM:4.02K OHM,1%,0.125W	75042	CEAT0-4021F
R496	321-0373-00			RES.,FXD,FILM:75K OHM,1%,0.125W	75042	CEAT0-7502F
R500	321-0203-00			RES.,FXD,FILM:1.27K OHM,1%,0.125W	75042	CEAT0-1271F
R502	321-0371-00			RES.,FXD,FILM:71.5K OHM,1%,0.125W	75042	CEAT0-7152F
R504	315-0113-00			RES.,FXD,COMP:11K OHM,5%,0.25W	01121	CB1135
R506	321-0251-00			RES.,FXD,FILM:4.02K OHM,1%,0.125W	75042	CEAT0-4021F
R508	315-0153-00			RES.,FXD,COMP:15K OHM,5%,0.25W	01121	CB1535
R510	315-0682-00			RES.,FXD,COMP:6.8K OHM,5%,0.25W	01121	CB6825
R512	315-0104-00			RES.,FXD,COMP:100K OHM,5%,0.25W	01121	CB1045
R514	315-0105-00			RES.,FXD,COMP:1M OHM,5%,0.25W	01121	CB1055
R516	321-0154-00			RES.,FXD,FILM:392 OHM,1%,0.125W	75042	CEAT0-3920F
R518	321-0251-00			RES.,FXD,FILM:4.02K OHM,1%,0.125W	75042	CEAT0-4021F
R520	321-0373-00			RES.,FXD,FILM:75K OHM,1%,0.125W	75042	CEAT0-7502F
R522	321-0235-00			RES.,FXD,FILM:2.74K OHM,1%,0.125W	75042	CEAT0-2741F
R524	321-0203-00			RES.,FXD,FILM:1.27K OHM,1%,0.125W	75042	CEAT0-1271F
R526	321-0371-00			RES.,FXD,FILM:71.5K OHM,1%,0.125W	75042	CEAT0-7152F
R528	321-0371-00			RES.,FXD,FILM:71.5K OHM,1%,0.125W	75042	CEAT0-7152F
R530	315-0113-00			RES.,FXD,COMP:11K OHM,5%,0.25W	01121	CB1135
R532	315-0153-00			RES.,FXD,COMP:15K OHM,5%,0.25W	01121	CB1535
R533	315-0562-00			RES.,FXD,COMP:5.6K OHM,5%,0.25W	01121	CB5625
R534	321-0251-00			RES.,FXD,FILM:4.02K OHM,1%,0.125W	75042	CEAT0-4021F
R536	315-0105-00			RES.,FXD,COMP:1M OHM,5%,0.25W	01121	CB1055
R538	321-0139-00			RES.,FXD,FILM:274 OHM,1%,0.125W	75042	CEAT0-2740F
R540	315-0104-00			RES.,FXD,COMP:100K OHM,5%,0.25W	01121	CB1045
R541	321-0373-00			RES.,FXD,FILM:75K OHM,1%,0.125W	75042	CEAT0-7502F
R542	321-0251-00			RES.,FXD,FILM:4.02K OHM,1%,0.125W	75042	CEAT0-4021F
R544	321-0235-00			RES.,FXD,FILM:2.74K OHM,1%,0.125W	75042	CEAT0-2741F
R546	321-0218-00			RES.,FXD,FILM:1.82K OHM,1%,0.125W	75042	CEAT0-1821F
R548	321-0371-00			RES.,FXD,FILM:71.5K OHM,1%,0.125W	75042	CEAT0-7152F
R552	321-0371-00			RES.,FXD,FILM:71.5K OHM,1%,0.125W	75042	CEAT0-7152F
R554	315-0224-00			RES.,FXD,COMP:220K OHM,5%,0.25W	01121	CB2245
R556	315-0104-00			RES.,FXD,COMP:100K OHM,5%,0.25W	01121	CB1045
R558	321-0251-00			RES.,FXD,FILM:4.02K OHM,1%,0.125W	75042	CEAT0-4021F
R560	315-0153-00			RES.,FXD,COMP:15K OHM,5%,0.25W	01121	CB1535
R562	315-0113-00			RES.,FXD,COMP:11K OHM,5%,0.25W	01121	CB1135
R566	315-0153-00			RES.,FXD,COMP:15K OHM,5%,0.25W	01121	CB1535
R580	321-0257-00			RES.,FXD,FILM:4.64K OHM,1%,0.125W	75042	CEAT0-4641F
R581	315-0101-00			RES.,FXD,COMP:100 OHM,5%,0.25W	01121	CB1015
R582	321-0161-00			RES.,FXD,FILM:464 OHM,1%,0.125W	75042	CEAT0-4640F
R584	315-0620-00			RES.,FXD,COMP:62 OHM,5%,0.25W	01121	CB6205
R586	315-0103-00			RES.,FXD,COMP:10K OHM,5%,0.25W	01121	CB1035
R588	315-0222-00			RES.,FXD,COMP:2.2K OHM,5%,0.25W	01121	CB2225
R590	315-0330-00			RES.,FXD,COMP:33 OHM,5%,0.25W	01121	CB3305
R592	315-0102-00			RES.,FXD,COMP:1K OHM,5%,0.25W	01121	CB1025
R593	315-0103-00			RES.,FXD,COMP:10K OHM,5%,0.25W	01121	CB1035
R594	315-0472-00			RES.,FXD,COMP:4.7K OHM,5%,0.25W	01121	CB4725
R596	315-0103-00			RES.,FXD,COMP:10K OHM,5%,0.25W	01121	CB1035
R598	315-0302-00			RES.,FXD,COMP:3K OHM,5%,0.25W	01121	CB3025
R599	315-0101-00			RES.,FXD,COMP:100 OHM,5%,0.25W	01121	CB1015
R600	311-1273-00			RES.,VAR,NONWIR:200K OHM,10%,0.50W		
R602	321-0423-00			RES.,FXD,FILM:249K OHM,1%,0.125W	75042	CEAT0-2493F
R604	321-0423-00			RES.,FXD,FILM:249K OHM,1%,0.125W	75042	CEAT0-2493F
R605	311-1273-00			RES.,VAR,NONWIR:200K OHM,10%,0.50W		
R606	315-0104-00			RES.,FXD,COMP:100K OHM,5%,0.25W	01121	CB1045
R608	321-0304-00			RES.,FXD,FILM:14.3K OHM,1%,0.125W	75042	CEAT0-1432F
R610	321-0155-00			RES.,FXD,FILM:402 OHM,1%,0.125W	75042	CEAT0-4020F
R612	321-0155-00			RES.,FXD,FILM:402 OHM,1%,0.125W	75042	CEAT0-4020F
R614	321-0254-00			RES.,FXD,FILM:4.32K OHM,1%,0.125W	75042	CEAT0-4321F



5L4N

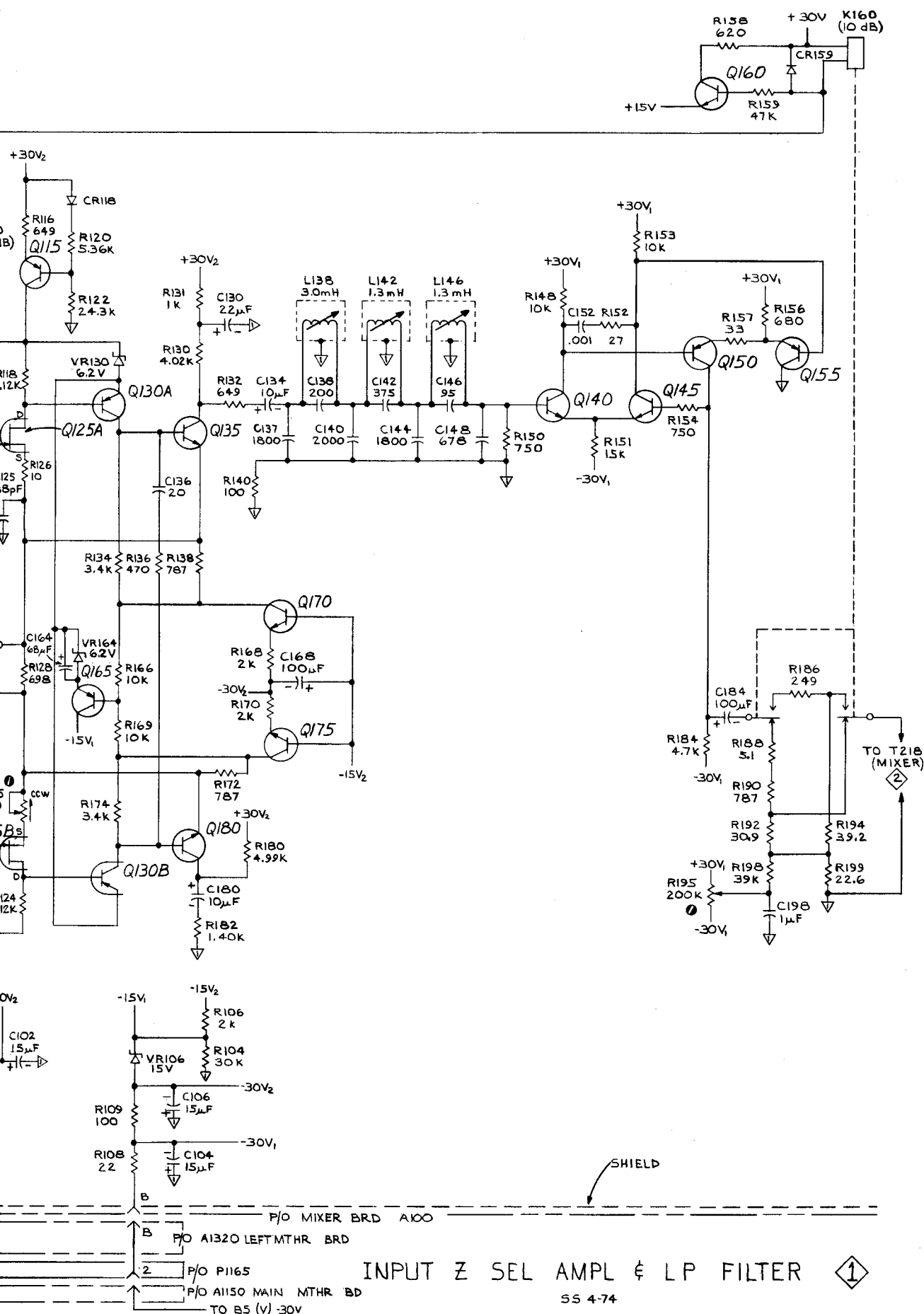

INPUT IMPD SEL AMPL & LP FILTER ①

INPUT Z SEL AMPL & LP FILTER ①

SS 4-74

P/O MIXER BRD A100
 P/O A1320 LEFTMTHR BRD
 P/O P1165
 P/O A1150 MAIN MTHR BD
 TO B5 (V) -30V

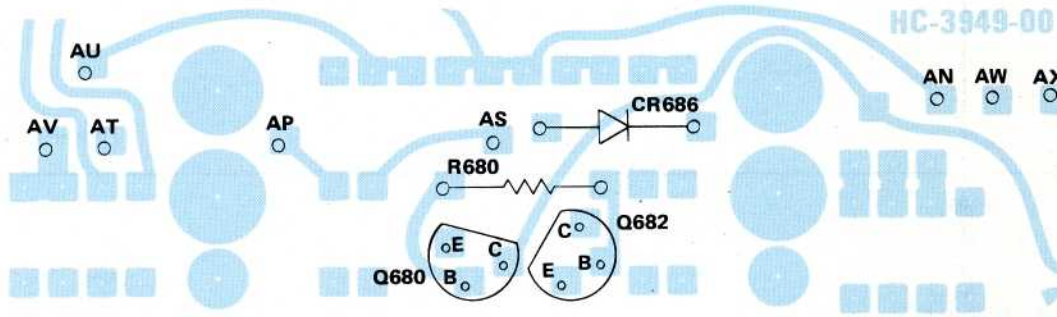

P/O A680A1 Vertical Sensing Selector

A1150 Main Mother Board component location shown on back of Diagram 9

COMPONENT LOCATIONS FOR DIAGRAM 2

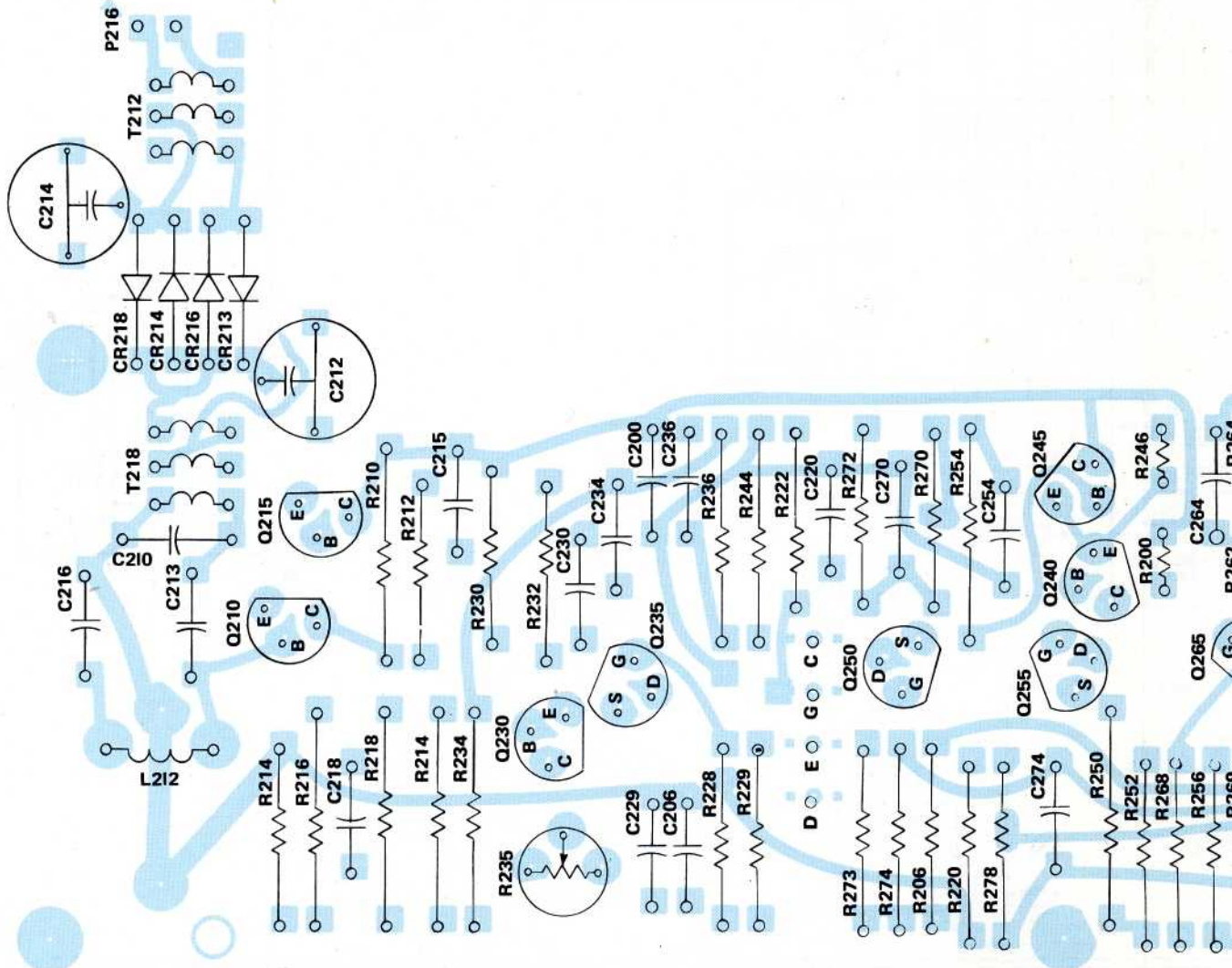

P/O A100 Input Amplifier, LP Filter, Mixer & 250

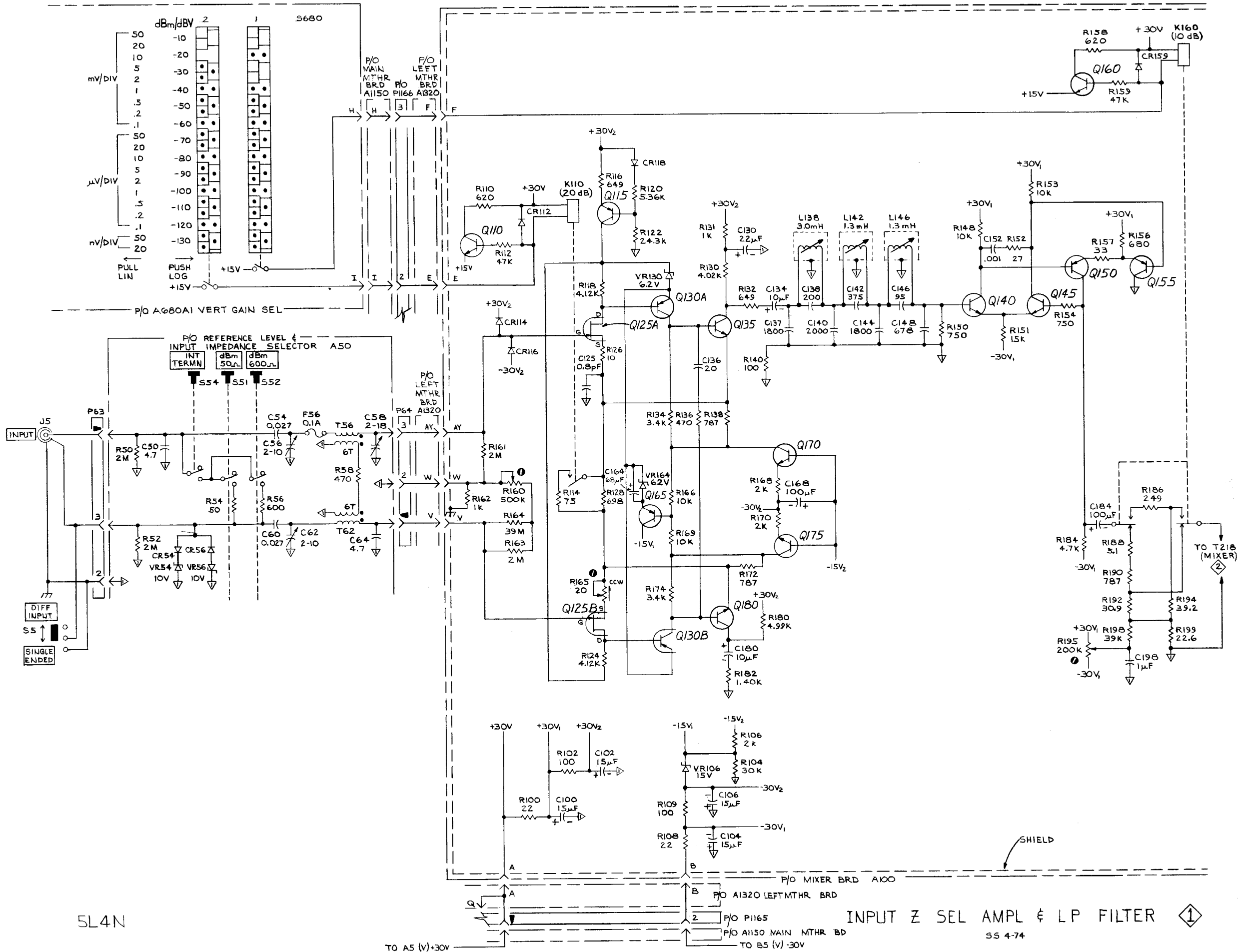

5L4N

TO A5 (V)+30V

TO B5 (V)-30V

INPUT Z SEL AMPL & LP FILTER ①

55 4-74

INPUT IMPD SEL AMPL & LP FILTER ①