

---

# BODY

## CONTENTS

<b>GENERAL</b> .....	<b>2</b>	<b>SUNROOF</b> .....	<b>9</b>
<b>OUTLINE OF CHANGE</b> .....	<b>2</b>	<b>SERVICE SPECIFICATIONS</b> .....	<b>9</b>
<b>KEYLESS ENTRY SYSTEM</b> .....	<b>2</b>	<b>SEALANT</b> .....	<b>9</b>
<b>SPECIAL TOOL</b> .....	<b>2</b>	<b>TROUBLESHOOTING</b> .....	<b>9</b>
<b>TROUBLESHOOTING</b> .....	<b>2</b>	<b>ON-VEHICLE SERVICE</b> .....	<b>13</b>
<b>KEYLESS ENTRY SYSTEM</b> .....	<b>7</b>	Water Test .....	13
<b>TRANSMITTER</b> .....	<b>7</b>	Sunroof Fit Adjustment .....	13
		<b>SUNROOF</b> .....	<b>14</b>



# GENERAL OUTLINE OF CHANGE

- The descriptions of the troubleshooting using on MUT-II tester have been incorporated.

## KEYLESS ENTRY SYSTEM

### SPECIAL TOOL

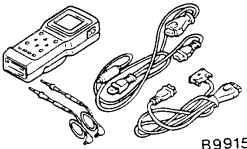
Tool	Number	Name	Use
 B991502	MB991502	MUT-II sub assembly	Recording secret codes

### TROUBLESHOOTING

#### INSPECTION CHART FOR TROUBLE SYMPTOMS

Trouble symptom	Inspection procedure No.	Reference page
None of the doors can be locked or unlocked using the transmitter.	1	42-2
All of the doors can be locked and unlocked using the transmitter, but the room lamp does not flash or illuminate. (However, the room lamp operates normally when the doors are opened and closed.)	2	42-4
Secret codes cannot be registered.	3	42-4

#### INSPECTION PROCEDURE FOR TROUBLE SYMPTOMS

##### INSPECTION PROCEDURE 1

None of the doors can be locked or unlocked using the transmitter.	Probable cause
The cause may be a malfunction of the transmitter, a malfunction of the receiver or the lock and unlock signals are not being input to the ETACS-ECU.	<ul style="list-style-type: none"> <li>Malfunction of transmitter</li> <li>Malfunction of receiver</li> <li>Malfunction of ETACS-ECU</li> <li>Malfunction of wiring harness or connector</li> <li>Malfunction of key reminder switch</li> <li>Malfunction of door switch</li> </ul>

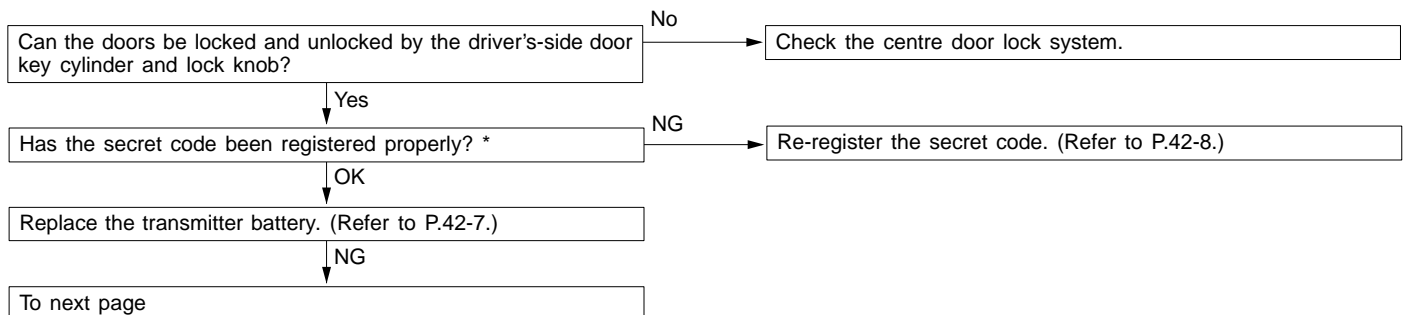

#### NOTE

\*: This should be done if a transmitter or receiver has been replaced, and if a secret code has not been registered properly.

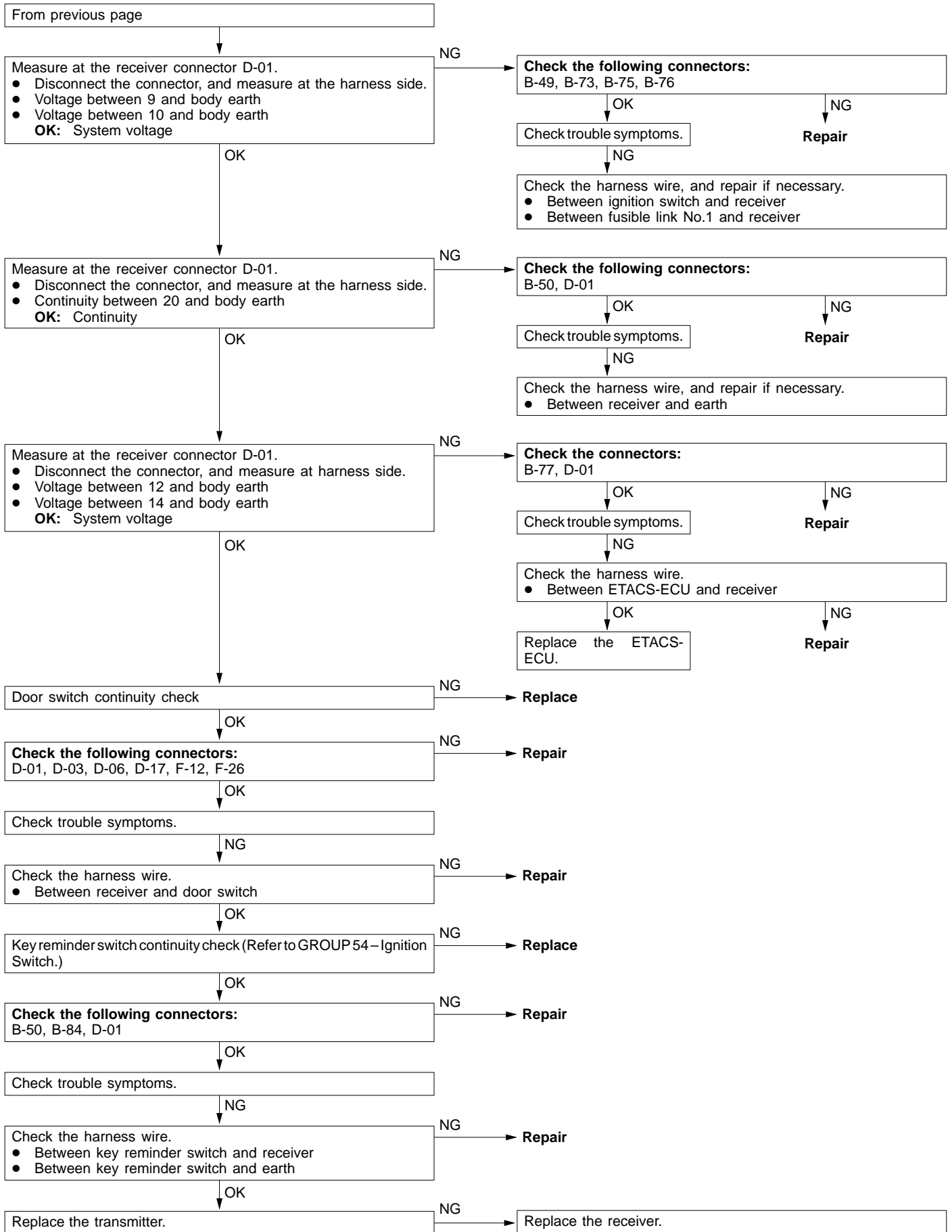

**INSPECTION PROCEDURE 2**

<p><b>All of the doors can be locked and unlocked using the transmitter, but the room lamp does not flash or illuminate. (However, the room lamp operates normally when the doors are opened and closed.)</b></p>	<p><b>Probable cause</b></p>
<p>If the room lamp operates normally when the doors are opened and closed, the cause of the problem may be a malfunction of the receiver or a malfunction of the harness between the room lamp the receiver.</p>	<ul style="list-style-type: none"> <li>• Malfunction of receiver</li> <li>• Malfunction of connector or wiring harness</li> </ul>

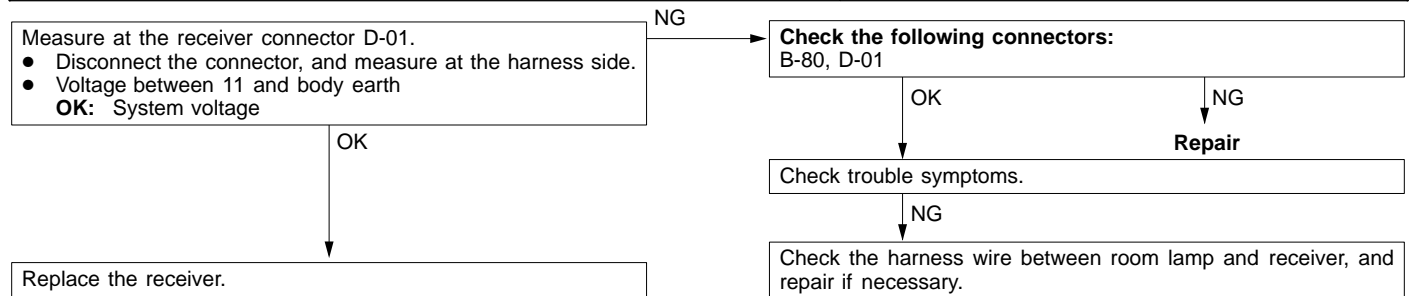

**INSPECTION PROCEDURE 3**

<p><b>Secret codes cannot be registered.</b></p> <p>The cause may be a malfunction of the diagnosis connector, a malfunction of the power supply or earth circuit of the receiver, a malfunction of the earth circuit or a malfunction of the diagnosis output circuit.</p>	<p><b>Probable cause</b></p> <ul style="list-style-type: none"> <li>• Malfunction of receiver</li> <li>• Malfunction of MUT-II</li> <li>• Malfunction of connector or wiring harness</li> </ul>
---	---

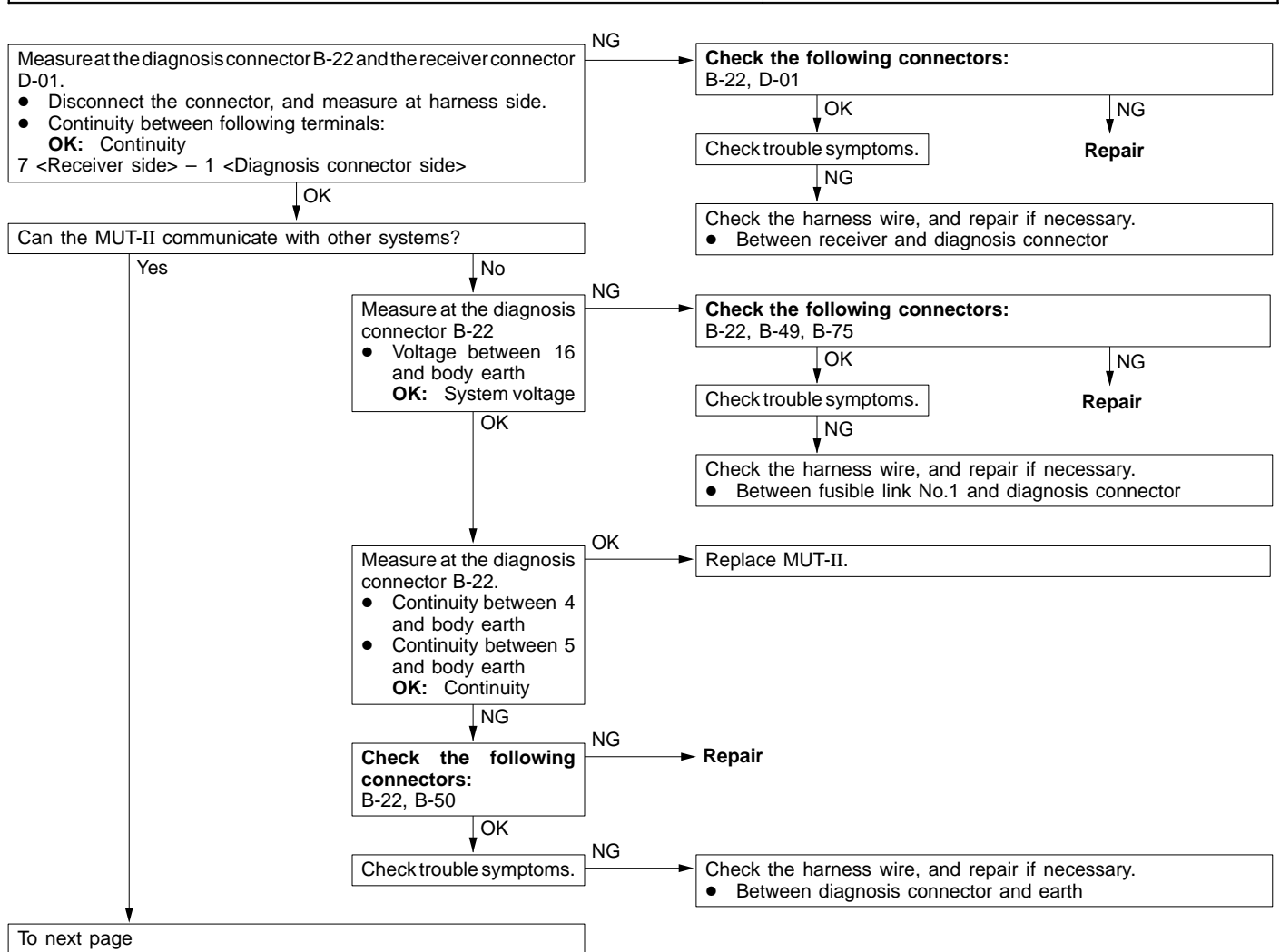

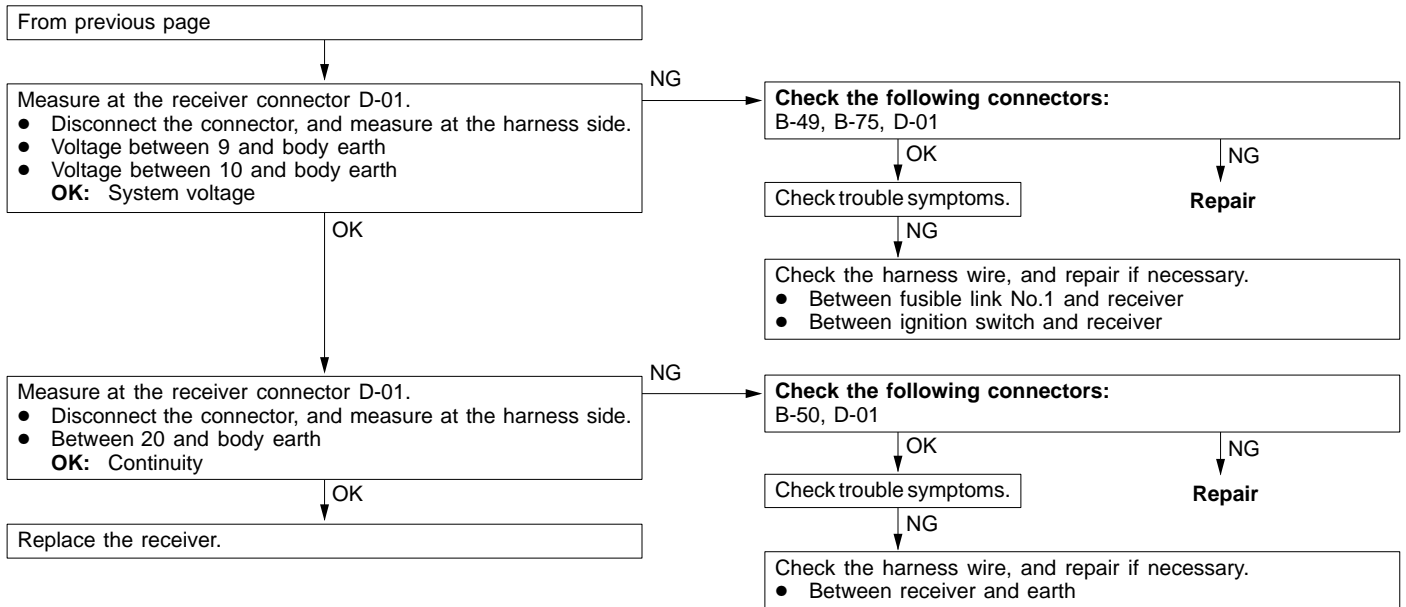

**INSPECTION OF RECEIVER TERMINAL VOLTAGE**

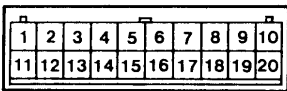

18W0311

Terminal	Signal name	Conditions	Terminal voltage
2	Door switch	One or more doors are open (Door switch: ON)	0 V
		All doors are closed (Door switch: OFF)	System voltage
6	Door lock actuator switch (driver's side)	LOCK	5 V and pulse output*
		UNLOCK	0 V
7	Diagnosis changeover input	When MUT-II is connected	0 V
		When MUT-II is disconnected	System voltage
8	Key reminder switch	OFF (When ignition key is inserted)	5 V and pulse output*
		ON (When ignition key is removed)	0 V
9	Ignition switch	Ignition switch: ACC or ON	System voltage
		Ignition switch: OFF	0 V
10	Receiver power supply	At all times	System voltage
11	Room lamp output	One or more door are open (Door switch: ON)	0 V
		All doors are closed (Door switch: OFF)	System voltage

Terminal	Signal name	Conditions	Terminal voltage
12	Door lock output	When activated	0 V
		When not activated	System voltage
14	Door unlock output	When activated	0 V
		When not activated	System voltage
20	Earth	At all times	0 V

**NOTE**

Values marked with \* should be measured using an oscilloscope. (The value will alternate between 0 V and 0.03 V if a circuit tester is used.)

# KEYLESS ENTRY SYSTEM

## REMOVAL AND INSTALLATION

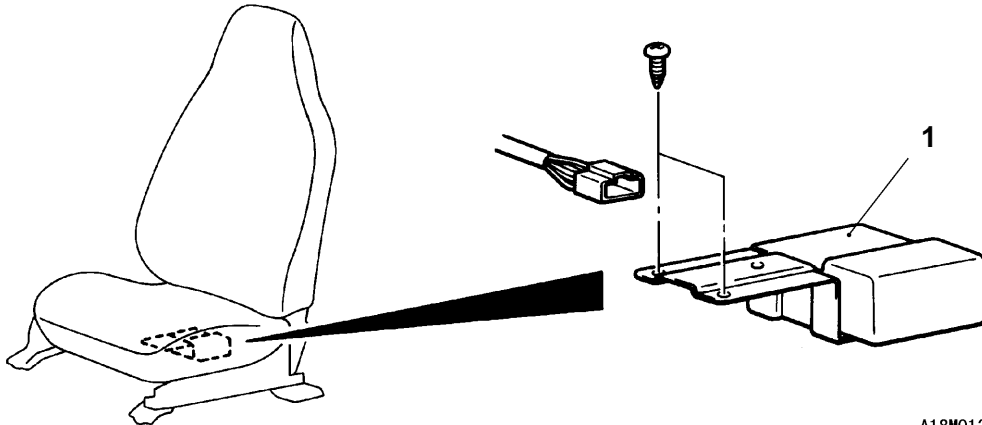

A18M0135

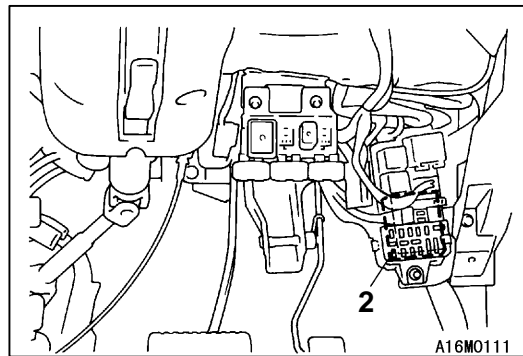

A16M0111

### Keyless entry receiver removal steps

- Front seat assembly (driver's side)
- 1. Keyless entry receiver

### ETACS-ECU removal

- 2. ETACS-ECU

# TRANSMITTER

## DISASSEMBLY AND REASSEMBLY

### Post-assembly Operation

- Transmitter operation check

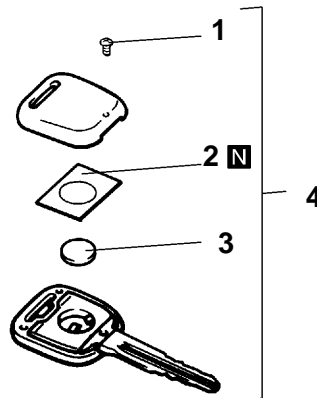

A18M0134

### Disassembly steps

- 1. Screw
- 2. Tape



- 3. Battery
- 4. Master key assembly

**ASSEMBLY SERVICE POINTS****▶A◀ BATTERY INSTALLATION**

Install a new battery with (+) side upward.

**Battery required for replacement:  
Lithium battery CR1216**

**SECRET CODE REGISTRATION METHOD**

Each individual secret code is registered inside the transmitter, and so it is necessary to register these codes with the EEPROM inside the receiver in the following cases.

- When either the transmitter or receiver is replaced;
- If it appears that a problem is occurring because of faulty registration of a code.

A maximum of two different codes can be stored in the memory area of the EEPROM (two different transmitters can be used). When the code for the first transmitter is registered, the previously-registered codes for two transmitters are cleared. Therefore, if you are using two transmitters or are adding a second transmitter, the codes for both transmitters must be registered at the same time. Before beginning with the registration, check that the doors lock normally when the key is used.

1. Connect the MUT-II to the diagnosis connector.

**NOTE**

This will connect terminal (1) of the diagnosis connector to earth, and the system will be in secret code registration standby mode.

**Caution**

**Always turn the ignition switch to OFF before connecting and disconnecting the MUT-II.**

2. Close all the doors.
3. Turn the ignition switch to ACC and then back to OFF.

**NOTE**

The doors will lock and unlock once at this time and the system will switch to registration mode.

4. Press the transmitter switch, and then press it two times within 10 seconds of the first press. This will register the code.
5. After registration is completed, the doors will be automatically locked and unlocked once.
6. If you are using two transmitters or have added a second transmitter, the same registration procedure should be carried out for the second transmitter, and it should be carried out within one minute after registration of the code for the first transmitter has been completed. After the second registration is completed, the doors will be automatically locked and unlocked once.
7. Registration mode will be cancelled if one of the following conditions is met.
  - When the secret codes for two transmitters have been registered;
  - When 1 minute has passed after registration mode started;
  - If the MUT-II is disconnected (the earth connection is broken);
  - If the ignition switch is turned to ON;
  - If any of the doors are opened;
8. After registration is completed, carry out the following to check if the keyless entry system is operable properly.
  - Remove the ignition key.
  - Close all the doors.



# SUNROOF

## SERVICE SPECIFICATIONS

Items	Standard value
Roof lid glass operating current A (at 20°C)	7 or less
Sunroof motor clutch slippage torque Nm	4.7 – 6.2

## SEALANT

Item	Specified sealant
Rail cover assembly	3M ATD Part No.8531 or 3M Part No.8646 or equivalent

## TROUBLESHOOTING

### INSPECTION CHART FOR TROUBLE SYMPTOMS

Trouble symptom	Inspection procedure	Reference page
The sunroof can not be operated when the ignition switch is in ON position.	1	42-9
The motor does not reverse its direction when a load of 140 N or more is applied while the sunroof is closing.	2	42-11
The timer does not operate for 30 seconds after the ignition switch is turned to OFF.	3	42-11
Opening or closing of the sunroof is possible for 30 seconds after turning the ignition switch to OFF, but the timer function is not extended when the driver's side door is opened within this period.	4	42-11

### INSPECTION PROCEDURE FOR TROUBLE SYMPTOMS

#### Inspection Procedure 1

The sunroof can not be operated when the ignition switch is in ON position.	Probable cause
One of the following items may be defective. <ul style="list-style-type: none"> <li>● Sunroof switch</li> <li>● Sunroof motor</li> <li>● Sunroof-ECU power supply circuit</li> <li>● Earth circuit</li> </ul>	<ul style="list-style-type: none"> <li>● Malfunction of sunroof switch</li> <li>● Malfunction of sunroof motor</li> <li>● Malfunction of sunroof-ECU</li> <li>● Malfunction of wiring harness or connector</li> </ul>

