

SUZUKI

GSX-R750

SERVICE MANUAL



FOREWORD

This manual contains an introductory description on the SUZUKI GSX-R750 and procedures for its inspection/service and overhaul of its main components.

Other information considered as generally known is not included.

Read the GENERAL INFORMATION section to familiarize yourself with the motorcycle and its maintenance. Use this section as well as other sections to use as a guide for proper inspection and service. This manual will help you know the motorcycle better so that you can assure your customers of fast and reliable service.

* This manual has been prepared on the basis of the latest specifications at the time of publication. If modifications have been made since then, differences may exist between the content of this manual and the actual motorcycle.

* Illustrations in this manual are used to show the basic principles of operation and work procedures. They may not represent the actual motorcycle exactly in detail.

* This manual is written for persons who have enough knowledge, skills and tools, including special tools, for servicing SUZUKI motorcycles. If you do not have the proper knowledge and tools, ask your authorized SUZUKI motorcycle dealer to help you.

⚠ WARNING

Inexperienced mechanics or mechanics without the proper tools and equipment may not be able to properly perform the services described in this manual. Improper repair may result in injury to the mechanic and may render the motorcycle unsafe for the rider and passenger.

GROUP INDEX

GENERAL INFORMATION	1
PERIODIC MAINTENANCE	2
ENGINE	3
FI SYSTEM DIAGNOSIS	4
FUEL SYSTEM AND THROTTLE BODY	5
EXHAUST SYSTEM	6
COOLING AND LUBRICATION SYSTEM	7
CHASSIS	8
ELECTRICAL SYSTEM	9
SERVICING INFORMATION	10
EMISSION CONTROL INFORMATION	11
WIRING DIAGRAM	12

HOW TO USE THIS MANUAL TO LOCATE WHAT YOU ARE LOOKING FOR:

1. The text of this manual is divided into sections.
2. The section titles are listed in the GROUP INDEX.
3. Holding the manual as shown at the right will allow you to find the first page of the section easily.
4. The contents are listed on the first page of each section to help you find the item and page you need.

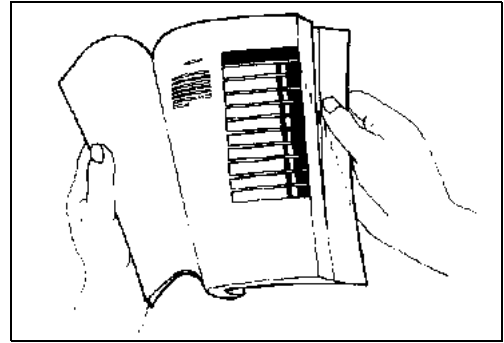

COMPONENT PARTS AND WORK TO BE DONE

Under the name of each system or unit, is its exploded view. Work instructions and other service information such as the tightening torque, lubricating points and locking agent points, are provided.

Example: Front wheel

①	Brake disc
②	Collar
③	Dust seal
④	Bearing
⑤	Spacer
⑥	Front axle
⑦	Front wheel
A	Front axle bolt
B	Brake disc bolt





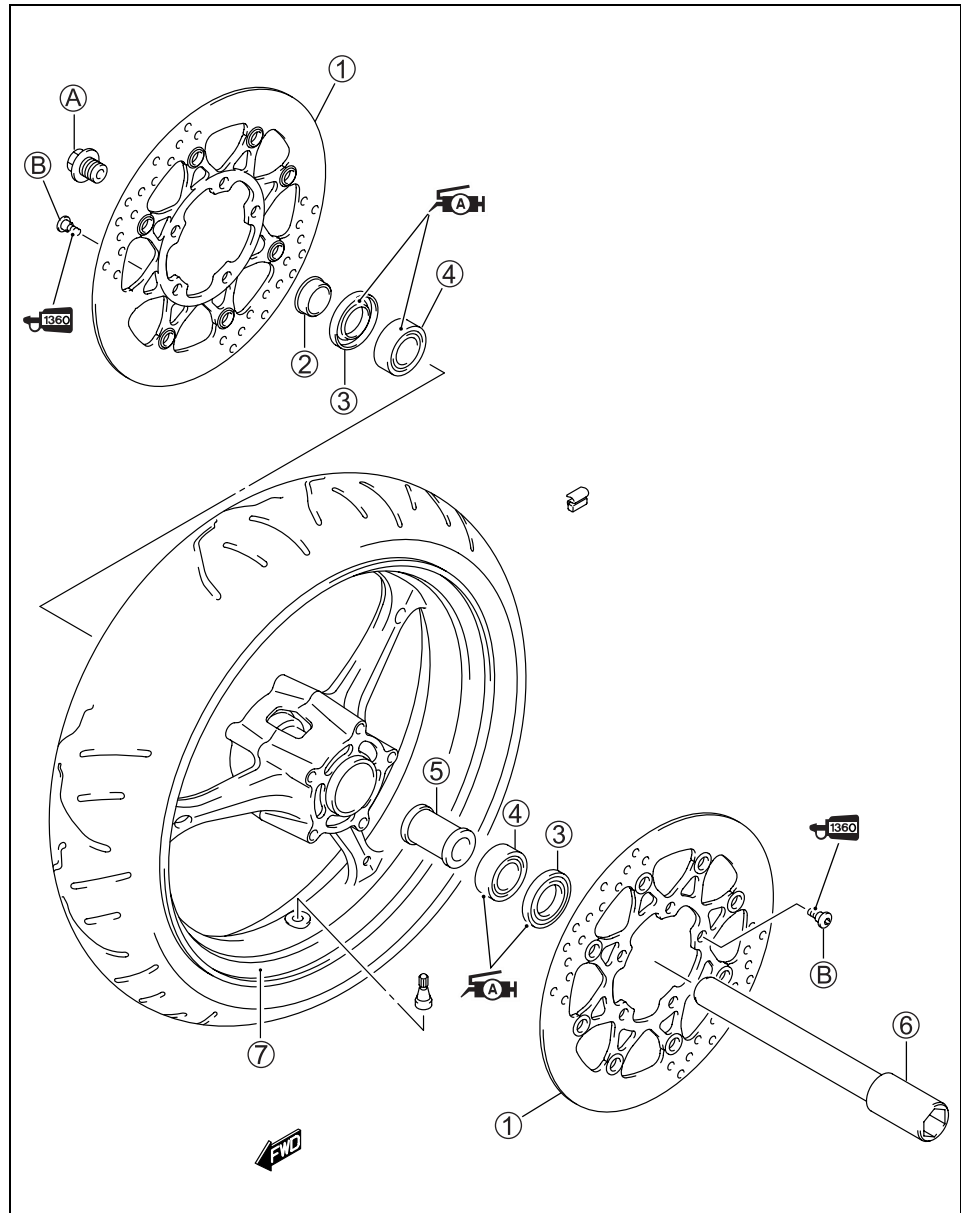



















ITEM	N·m	kgf·m	lb·ft
A	100	10.0	72.5
B	23	2.3	16.5



SYMBOL

Listed in the table below are the symbols indicating instructions and other information necessary for servicing. The meaning of each symbol is also included in the table.

SYMBOL	DEFINITION	SYMBOL	DEFINITION
	Torque control required. Data beside it indicates specified torque.		Apply THREAD LOCK SUPER "1360". 99000-32130
	Apply oil. Use engine oil unless otherwise specified.		Use engine coolant. 99000-99032-11X (Except USA)
	Apply molybdenum oil solution. (Mixture of engine oil and SUZUKI MOLY PASTE in a ratio of 1:1)		Use fork oil. 99000-99001-SS5
	Apply SUZUKI SUPER GREASE "A" or equivalent grease. 99000-25010		Apply or use brake fluid.
	Apply SUZUKI SILICONE GREASE. 99000-25100		Measure in voltage range.
	Apply SUZUKI MOLY PASTE. 99000-25140		Measure in current range.
	Apply SUZUKI BOND "1215" or equivalent bond. 99000-31110		Measure in resistance range.
	Apply SUZUKI BOND "1207B". 99000-31140		Measure in diode test range.
	Apply THREAD LOCK SUPER "1303". 99000-32030		Measure in continuity test range.
	Apply THREAD LOCK SUPER "1322" or equivalent thread lock. 99000-32110		Use special tool.
	Apply THREAD LOCK "1342". 99000-32050		Indication of service data.

ABBREVIATIONS USED IN THIS MANUAL

A		E	
ABDC	: After Bottom Dead Center	ECM	: Engine Control Module
AC	: Alternating Current		: Engine Control Unit (ECU) (FI Control Unit)
ACL	: Air Cleaner, Air Cleaner Box	ECT Sensor	: Engine Coolant Temperature Sensor (ECTS), Water Temp. Sensor (WTS)
API	: American Petroleum Institute	EVAP	: Evaporative Emission
ATDC	: After Top Dead Center	EVAP Canister	: Evaporative Emission Canister (Canister)
ATM Pressure	: Atmospheric Pressure	EXC System	: Exhaust Control System (EXCS)
	: Atmospheric Pressure sensor (APS, AP Sensor)	EXC Valve	: Exhaust Control Valve (EXCV)
A/F	: Air Fuel Mixture	EXCV Actuator	: Exhaust Control Valve Actuator (EXCVA)
B		F	
BBDC	: Before Bottom Dead Center	FI	: Fuel Injection, Fuel Injector
BTDC	: Before Top Dead Center	FP	: Fuel Pump
B+	: Battery Positive Voltage	FPR	: Fuel Pressure Regulator
C		FP Relay	: Fuel Pump Relay
CKP Sensor	: Crankshaft Position Sensor (CKPS)	G	
CKT	: Circuit	GEN	: Generator
CLP Switch	: Clutch Lever Position Switch (Clutch Switch)	GND	: Ground
CMP Sensor	: Camshaft Position Sensor (CMPS)	GP Switch	: Gear Position Switch
CO	: Carbon Monoxide	H	
CPU	: Central Processing Unit	HC	: Hydrocarbons
D		I	
DC	: Direct Current	IAP Sensor	: Intake Air Pressure Sensor (IAPS) (MAP Sensor)
DMC	: Dealer Mode Coupler	IAT Sensor	: Intake Air Temperature Sensor (IATS)
DOHC	: Double Over Head Camshaft	IG	: Ignition
DRL	: Daytime Running Light	L	
DTC	: Diagnostic Trouble Code	LCD	: Liquid Crystal Display
		LED	: Light Emitting Diode (Malfunction Indicator Lamp)
		LH	: Left Hand

M

MAL-Code : Malfunction Code
(Diagnostic Code)
Max : Maximum
MIL : Malfunction Indicator Lamp
(LED)
Min : Minimum

N

NOX : Nitrogen Oxides

O

OHC : Over Head Camshaft
OPS : Oil Pressure Switch

P

PCV : Positive Crankcase
Ventilation (Crankcase Breather)

R

RH : Right Hand
ROM : Read Only Memory

S

SAE : Society of Automotive Engineers
SDS : Suzuki Diagnosis System
STC System : Secondary Throttle Control System
(STCS)
STP Sensor : Secondary Throttle Position Sensor
(STPS)
ST Valve : Secondary Throttle Valve (STV)
STV Actuator : Secondary Throttle Valve Actuator
(STVA)

T

TO Sensor : Tip-Over Sensor (TOS)
TP Sensor : Throttle Position Sensor (TPS)

WIRE COLOR

B	: Black	G	: Green	P	: Pink
Bl	: Blue	Gr	: Gray	R	: Red
Br	: Brown	Lbl	: Light blue	W	: White
Dg	: Dark green	Lg	: Light green	Y	: Yellow
Dgr	: Dark gray	O	: Orange		

B/Bl	: Black with Blue tracer	B/Br	: Black with Brown tracer
B/G	: Black with Green tracer	B/Lg	: Black with Light green tracer
B/R	: Black with Red tracer	B/W	: Black with White tracer
B/Y	: Black with Yellow tracer	Bl/B	: Blue with Black tracer
Bl/G	: Blue with Green tracer	Bl/R	: Blue with Red tracer
Bl/W	: Blue with White tracer	Bl/Y	: Blue with Yellow tracer
Br/Y	: Brown with Yellow tracer	G/B	: Green with Black tracer
G/Bl	: Green with Blue tracer	G/R	: Green with Red tracer
G/W	: Green with White tracer	G/Y	: Green with Yellow tracer
Gr/B	: Gray with Black tracer	Gr/R	: Gray with Red tracer
Gr/W	: Gray with White tracer	Gr/Y	: Gray with Yellow tracer
Lg/Bl	: Light green with Blue tracer	Lg/G	: Light green with Green tracer
Lg/W	: Light green with White tracer	O/B	: Orange with Black tracer
O/Bl	: Orange with Blue tracer	O/G	: Orange with Green tracer
O/R	: Orange with Red tracer	O/W	: Orange with White tracer
O/Y	: Orange with Yellow tracer	P/B	: Pink with Black tracer
P/W	: Pink with White tracer	R/B	: Red with Black tracer
R/Bl	: Red with Blue tracer	R/Y	: Red with Yellow tracer
R/W	: Red with White tracer	W/B	: White with Black tracer
W/Bl	: White with Blue tracer	W/G	: White with Green tracer
W/R	: White with Red tracer	W/Y	: White with Yellow tracer
Y/B	: Yellow with Black tracer	Y/Bl	: Yellow with Blue tracer
Y/G	: Yellow with Green tracer	Y/R	: Yellow with Red tracer
Y/W	: Yellow with White tracer		

GENERAL INFORMATION

1

CONTENTS

WARNING/CAUTION/NOTE	1- 2
GENERAL PRECAUTIONS	1- 2
SUZUKI GSX-R750K6 ('06-MODEL)	1- 4
SERIAL NUMBER LOCATION	1- 4
FUEL, OIL AND ENGINE COOLANT RECOMMENDATION	1- 5
FUEL (FOR USA AND CANADA)	1- 5
FUEL (FOR OTHER COUNTRIES)	1- 5
ENGINE OIL (FOR USA)	1- 5
ENGINE OIL (FOR OTHER COUNTRIES)	1- 5
BRAKE FLUID	1- 5
FRONT FORK OIL	1- 6
ENGINE COOLANT	1- 6
WATER FOR MIXING	1- 6
ANTI-FREEZE/ENGINE COOLANT	1- 6
LIQUID AMOUNT OF WATER/ENGINE COOLANT	1- 6
BREAK-IN PROCEDURES	1- 7
CYLINDER IDENTIFICATION	1- 7
INFORMATION LABELS	1- 8
SPECIFICATIONS	1- 9
DIMENSIONS AND DRY MASS	1- 9
ENGINE	1- 9
DRIVE TRAIN	1- 9
CHASSIS	1-10
ELECTRICAL	1-10
CAPACITIES	1-10

COUNTRY AND AREA CODES

The following codes stand for the applicable country(-ies) and area(-s).

CODE	COUNTRY or AREA	EFFECTIVE FRAME NO.
E-02	U.K.	JS1CF111100100001 –
E-19 (GSX-R750)	E.U.	JS1CF111100100001 –
E-19 (GSX-R750U2)	E.U.	JS1CF211100100001 –
E-24	Australia	JS1CF121300100001 –
E-03	U.S.A. (Except for California)	JS1GR7KA 62100001 –
E-28	Canada	JS1GR7KA 62100001 –
E-33	California (U.S.A.)	JS1GR7KA 62100001 –

WARNING/CAUTION/NOTE

Please read this manual and follow its instructions carefully. To emphasize special information, the symbol and the words WARNING, CAUTION and NOTE have special meanings. Pay special attention to the messages highlighted by these signal words.

⚠ WARNING

Indicates a potential hazard that could result in death or injury.

CAUTION

Indicates a potential hazard that could result in motorcycle damage.

NOTE:

Indicates special information to make maintenance easier or instructions clearer.

Please note, however, that the warnings and cautions contained in this manual cannot possibly cover all potential hazards relating to the servicing, or lack of servicing, of the motorcycle. In addition to the WARNINGS and CAUTIONS stated, you must use good judgement and basic mechanical safety principles. If you are unsure about how to perform a particular service operation, ask a more experienced mechanic for advice.

GENERAL PRECAUTIONS

⚠ WARNING

- * **Proper service and repair procedures are important for the safety of the service mechanic and the safety and reliability of the motorcycle.**
 - * **When 2 or more persons work together, pay attention to the safety of each other.**
 - * **When it is necessary to run the engine indoors, make sure that exhaust gas is forced outdoors.**
 - * **When working with toxic or flammable materials, make sure that the area you work in is well-ventilated and that you follow all of the material manufacturer's instructions.**
 - * **Never use gasoline as a cleaning solvent.**
 - * **To avoid getting burned, do not touch the engine, engine oil, radiator and exhaust system until they have cooled.**
- After servicing the fuel, oil, water, exhaust or brake systems, check all lines and fittings related to the system for leaks.**

CAUTION

- * If parts replacement is necessary, replace the parts with Suzuki Genuine Parts or their equivalent.
- * When removing parts that are to be reused, keep them arranged in an orderly manner so that they may be reinstalled in the proper order and orientation.
- * Be sure to use special tools when instructed.
- * Make sure that all parts used in reassembly are clean. Lubricate them when specified.
- * Use the specified lubricant, bond, or sealant.
- * When removing the battery, disconnect the negative cable first and then the positive cable.
- * When reconnecting the battery, connect the positive cable first and then the negative cable, and replace the terminal cover on the positive terminal.
- * When performing service to electrical parts, if the service procedures do not require use of battery power, disconnect the negative cable from the battery.
- * When tightening the cylinder head or case bolts and nuts, tighten the larger sizes first. Always tighten the bolts and nuts diagonally from the inside toward outside and to the specified tightening torque.
- * Whenever you remove oil seals, gaskets, packing, O-rings, locking washers, self-locking nuts, cotter pins, circlips and certain other parts as specified, be sure to replace them with new ones. Also, before installing these new parts, be sure to remove any left over material from the mating surfaces.
- * Never reuse a circlip. When installing a new circlip, take care not to expand the end gap larger than required to slip the circlip over the shaft. After installing a circlip, always ensure that it is completely seated in its groove and securely fitted.
- * Use a torque wrench to tighten fasteners to the specified torque. Wipe off grease and oil if a thread is smeared with them.
- * After reassembling, check parts for tightness and proper operation.

- * To protect the environment, do not unlawfully dispose of used motor oil, engine coolant and other fluids: batteries and tires.
- * To protect Earth's natural resources, properly dispose of used motorcycle and parts.

SUZUKI GSX-R750K6 ('06-MODEL)

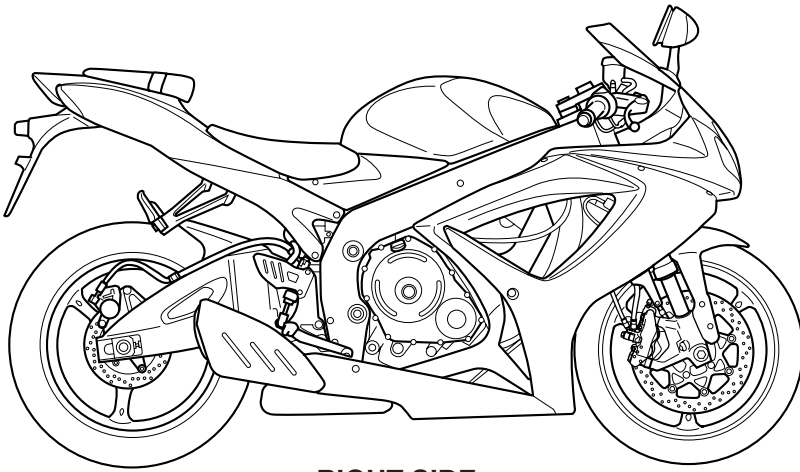

RIGHT SIDE

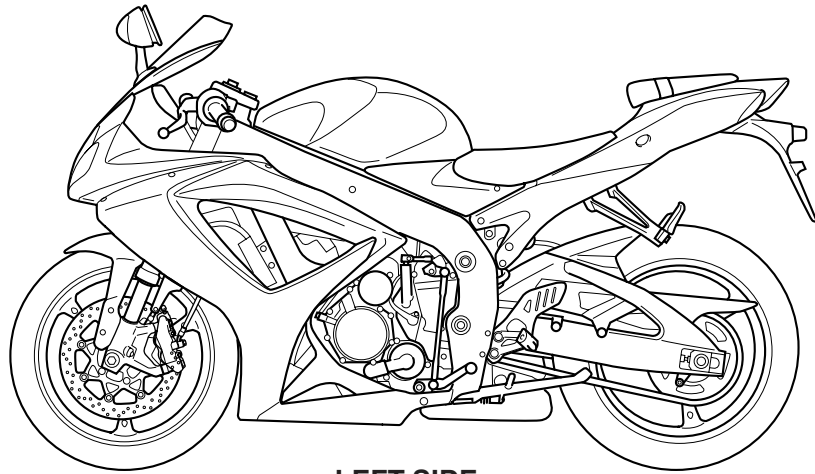

LEFT SIDE

- Difference between illustrations and actual motorcycle may exist depending on the markets.

SERIAL NUMBER LOCATION

The frame serial number or V.I.N. (Vehicle Identification Number) ① is stamped on the right side of the steering head pipe. The engine serial number ② is located on the right side of the crankcase. These numbers are required especially for registering the machine and ordering spare parts.

