

SUZUKI

GSX1300BK

BKING

SERVICE MANUAL

SAMPLE



FOREWORD

This manual contains an introductory description on the SUZUKI GSX1300BK and procedures for its inspection/service and overhaul of its main components.

Other information considered as generally known is not included.

Read the GENERAL INFORMATION section to familiarize yourself with the motorcycle and its maintenance. Use this section as well as other sections to use as a guide for proper inspection and service.

This manual will help you know the motorcycle better so that you can assure your customers of fast and reliable service.

** This manual has been prepared on the basis of the latest specifications at the time of publication. If modifications have been made since then, differences may exist between the content of this manual and the actual motorcycle.*

** Illustrations in this manual are used to show the basic principles of operation and work procedures. They may not represent the actual motorcycle exactly in detail.*

** This manual is written for persons who have enough knowledge, skills and tools, including special tools, for servicing SUZUKI motorcycles. If you do not have the proper knowledge and tools, ask your authorized SUZUKI motorcycle dealer to help you.*

▲ WARNING

Inexperienced mechanics or mechanics without the proper tools and equipment may not be able to properly perform the services described in this manual.

Improper repair may result in injury to the mechanic and may render the motorcycle unsafe for the rider and passenger.

SAMPLE

SUZUKI MOTOR CORPORATION

TABLE OF CONTENTS

Precautions.....	00-i
Precautions	00-1
General Information	0-i
General Information	0A-1
Maintenance and Lubrication	0B-1
Service Data.....	0C-1
Engine	1-i
Precautions	1-1
Engine General Information and Diagnosis	1A-1
Emission Control Devices	1B-1
Engine Electrical Devices.....	1C-1
Engine Mechanical.....	1D-1
Engine Lubrication System	1E-1
Engine Cooling System.....	1F-1
Fuel System	1G-1
Ignition System.....	1H-1
Starting System.....	1I-1
Charging System.....	1J-1
Exhaust System	1K-1
Suspension.....	2-i
Precautions	2-1
Suspension General Diagnosis	2A-1
Front Suspension.....	2B-1
Rear Suspension.....	2C-1
Wheels and Tires	2D-1
Driveline / Axle	3-i
Precautions	3-1
Drive Chain / Drive Train / Drive Shaft.....	3A-1
Brake	4-i
Precautions	4-1
Brake Control System and Diagnosis	4A-1
Front Brakes.....	4B-1
Rear Brakes	4C-1
Transmission / Transaxle	5-i
Precautions	5-1
Manual Transmission	5B-1
Clutch	5C-1
Steering.....	6-i
Precautions	6-1
Steering General Diagnosis	6A-1
Steering / Handlebar	6B-1
Body and Accessories.....	9-i
Precautions	9-1
Wiring Systems	9A-1
Lighting Systems.....	9B-1
Combination Meter / Fuel Meter / Horn.....	9C-1
Exterior Parts	9D-1
Body Structure	9E-1

SAMPLE

00

0

1

2

3

4

5

6

9

SAMPLE

Section 00

Precautions

CONTENTS

Precautions	00-1	General Precautions	00-1
Precautions	00-1	Precautions for Electrical Circuit Service	00-2
Warning / Caution / Note.....	00-1		

SAMPLE

Precautions

Precautions

Warning / Caution / Note

B823H1000001

Please read this manual and follow its instructions carefully. To emphasize special information, the symbol and the words WARNING, CAUTION and NOTE have special meanings. Pay special attention to the messages highlighted by these signal words.

▲ WARNING

Indicates a potential hazard that could result in death or injury.

▲ CAUTION

Indicates a potential hazard that could result in motorcycle damage.

NOTE

Indicates special information to make maintenance easier or instructions clearer.

Please note, however, that the warnings and cautions contained in this manual cannot possibly cover all potential hazards relating to the servicing, or lack of servicing, of the motorcycle. In addition to the WARNINGS and CAUTIONS stated, you must use good judgement and basic mechanical safety principles. If you are unsure about how to perform a particular service operation, ask a more experienced mechanic for advice.

General Precautions

B823H1000002

▲ WARNING

- Proper service and repair procedures are important for the safety of the service mechanic and the safety and reliability of the motorcycle.
- When 2 or more persons work together, pay attention to the safety of each other.
- When it is necessary to run the engine indoors, make sure that exhaust gas is forced outdoors.
- When working with toxic or flammable materials, make sure that the area you work in is well ventilated and that you follow all of the material manufacturer's instructions.
- Never use gasoline as a cleaning solvent.

- To avoid getting burned, do not touch the engine, engine oil, radiator and exhaust system until they have cooled.
- After servicing the fuel, oil, water, exhaust or brake systems, check all lines and fittings related to the system for leaks.

▲ CAUTION

- If parts replacement is necessary, replace the parts with Suzuki Genuine Parts or their equivalent.
- When removing parts that are to be reused, keep them arranged in an orderly manner so that they may be reinstalled in the proper order and orientation.
- Be sure to use special tools when instructed.
- Make sure that all parts used in reassembly are clean. Lubricate them when specified.
- Use the specified lubricant, bond or sealant.
- When removing the battery, disconnect the negative (-) cable first and then the positive (+) cable.
- When reconnecting the battery, connect the positive (+) cable first and then the negative (-) cable, and replace the terminal cover on the positive (+) terminal.
- When performing service to electrical parts, if the service procedures do not require use of battery power, disconnect the negative (-) cable the battery.
- When tightening the cylinder head or case bolts and nuts, tighten the larger sizes first. Always tighten the bolts and nuts diagonally from the inside toward outside and to the specified tightening torque.
- Whenever you remove oil seals, gaskets, packing, O-rings, locking washers, self-locking nuts, cotter pins, circlips and certain other parts as specified, be sure to replace them with new ones. Also, before installing these new parts, be sure to remove any left over material from the mating surfaces.

- **Never reuse a circlip. When installing a new circlip, take care not to expand the end gap larger than required to slip the circlip over the shaft. After installing a circlip, always ensure that it is completely seated in its groove and securely fitted.**
- **Use a torque wrench to tighten fasteners to the specified torque. Wipe off grease and oil if a thread is smeared with them.**
- **After reassembling, check parts for tightness and proper operation.**
- **To protect the environment, do not unlawfully dispose of used motor oil, engine coolant and other fluids: batteries, and tires.**
- **To protect Earth's natural resources, properly dispose of used motorcycle and parts.**

Precautions for Electrical Circuit Service

B823H1000003

When handling the electrical parts or servicing the FI and ABS systems, observe the following points for the safety of the systems.

Electrical Parts

Connector / Coupler

- When connecting a connector, be sure to push it in until a click is felt.

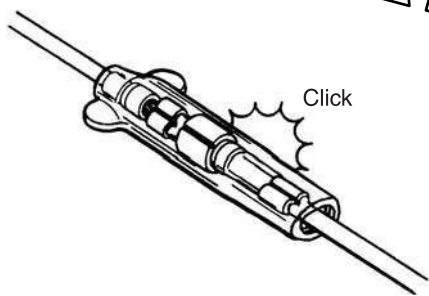

I823H1000002-01

- With a lock type coupler, be sure to release the lock when disconnecting, and push it in fully to engage the lock when connecting.
- When disconnecting the coupler, be sure to hold the coupler body and do not pull the lead wires.
- Inspect each terminal on the connector/coupler for looseness or bending.
- Push in the coupler straightly. An angled or skewed insertion may cause the terminal to be deformed, possibly resulting in poor electrical contact.
- Inspect each terminal for corrosion and contamination. The terminals must be clean and free of any foreign material which could impede proper terminal contact.

- Before refitting the sealed coupler, make sure its seal rubber is positioned properly. The seal rubber may possibly come off the position during disconnecting work and if the coupler is refitted with the seal rubber improperly positioned, it may result in poor water sealing.

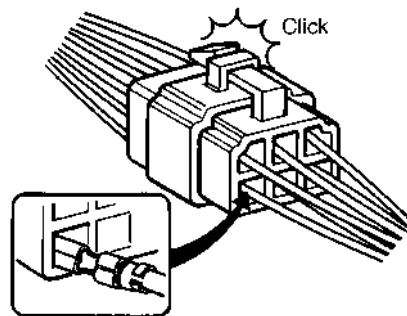

I310G1000002-01

- Inspect each lead wire circuit for poor connection by shaking it by hand lightly. If any abnormal condition is found, repair or replace.

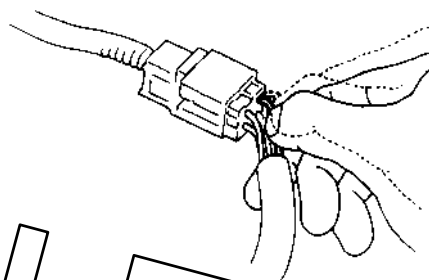

I310G1000003-02

- When taking measurements at electrical connectors using a tester probe, be sure to insert the probe from the wire harness side (rear) of the connector/coupler.

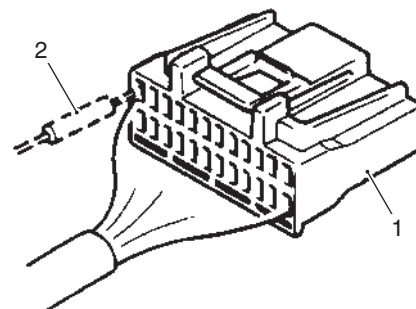

I649G1000013-02

1. Coupler	2. Probe
------------	----------

- When connecting meter probe from the terminal side of the coupler (where connection from harness side not being possible), use extra care not to force and cause the male terminal to bend or the female terminal to open. Connect the probe as shown to avoid opening of female terminal. Never push in the probe where male terminal is supposed to fit.

00-3 Precautions:

- Check the male connector for bend and female connector for excessive opening. Also check the coupler for locking (looseness), corrosion, dust, etc.

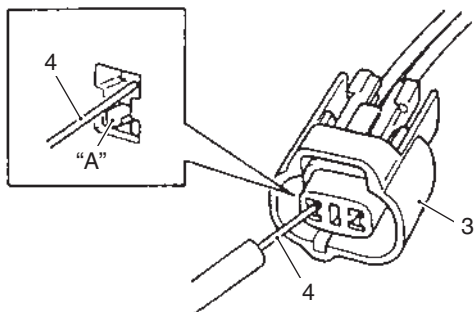

I649G1000030-02

3. Coupler	4. Probe	"A": Where male terminal fits
------------	----------	-------------------------------

Clamp

- Clamp the wire harness at such positions as indicated in "Wiring Harness Routing Diagram in Section 9A (Page 9A-5)".
- Bend the clamp properly so that the wire harness is clamped securely.
- In clamping the wire harness, use care not to allow it to hang down.
- Do not use wire or any other substitute for the band type clamp.

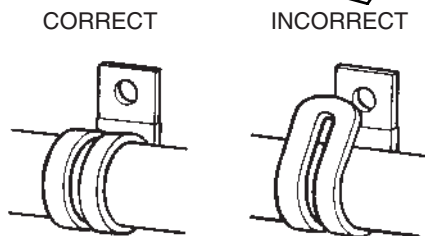

I718H1000001-02

Fuse

- When a fuse is blown, always investigate the cause to correct it and then replace the fuse.
- Do not use a fuse of different capacity.
- Do not use wire or any other substitute for the fuse.

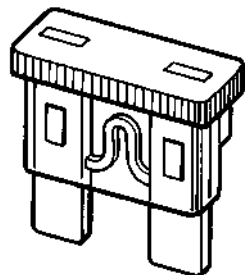

I649G1000001-02

Switch

Never apply grease material to switch contact points to prevent damage.

ECM / Various sensors

- Since each component is a high-precision part, great care should be taken not to apply any severe impacts during removal and installation.

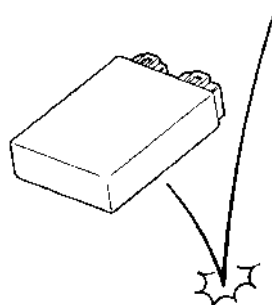

I310G1000007-01

- Be careful not to touch the electrical terminals of the electronic parts (ECM, etc.). The static electricity from your body may damage them.

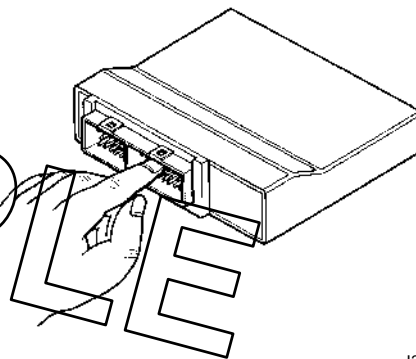

I310G1000008-01

- When disconnecting and connecting the coupler, make sure to turn OFF the ignition switch, or electronic parts may get damaged.

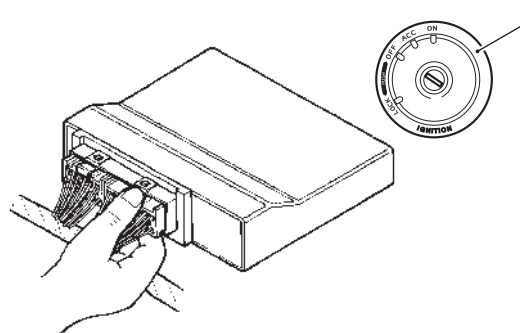

I823H1000001-02

1. Ignition switch

Battery

- Battery connection in reverse polarity is strictly prohibited. Such a wrong connection will damage the components of the FI and ABS systems instantly when reverse power is applied.

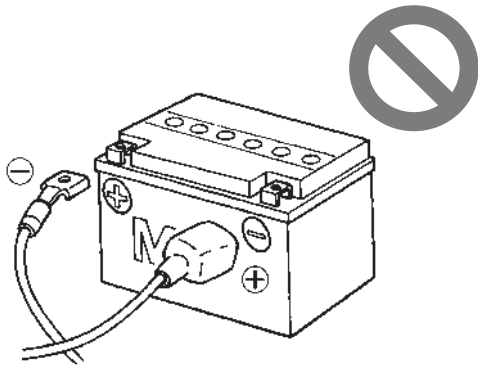

I718H1000004-01

- Removing any battery terminal of a running engine is strictly prohibited. The moment such removal is made, damaging counter electromotive force will be applied to the electronic unit which may result in serious damage.

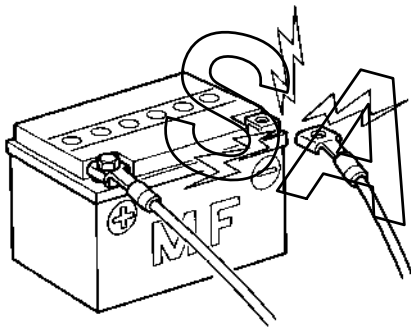

I310G1000011-01

- Before measuring voltage at each terminal, check to make sure that battery voltage is 11 V or higher. Terminal voltage check with a low battery voltage will lead to erroneous diagnosis.

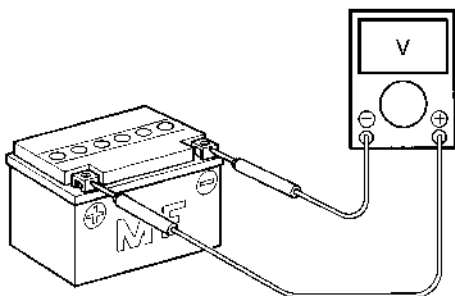

I310G1000012-02

- Never connect any tester (voltmeter, ohmmeter, or whatever) to the electronic unit when its coupler is disconnected. Otherwise, damage to electronic unit may result.
- Never connect an ohmmeter to the electronic unit with its coupler connected. If attempted, damage to ECM or sensors may result.
- Be sure to use a specified voltmeter/ohmmeter. Otherwise, accurate measurements may not be obtained and personal injury may result.

Electrical Circuit Inspection Procedure

While there are various methods for electrical circuit inspection, described here is a general method to check for open and short circuit using an ohmmeter and a voltmeter.

Open circuit check

Possible causes for the open circuit are as follows. As the cause can exist in the connector/coupler or terminal, they need to be checked carefully.

- Loose connection of connector/coupler
- Poor contact of terminal (due to dirt, corrosion or rust, poor contact tension, entry of foreign object etc.)
- Wire harness being open.
- Poor terminal-to-wire connection.

When checking system circuits including an electronic control unit such as ECM, ABS control unit/HU, etc., it is important to perform careful check, starting with items which are easier to check.

- 1) Disconnect the negative (-) cable from the battery.
- 2) Check each connector/coupler at both ends of the circuit being checked for loose connection. Also check for condition of the coupler lock if equipped.

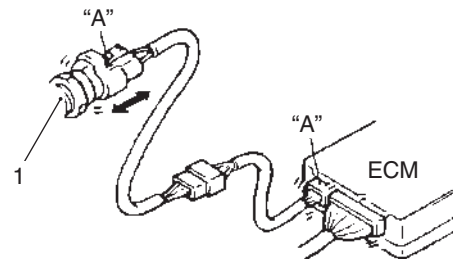

I718H1000005-02

1. Sensor	"A": Check for loose connection
-----------	---------------------------------

00-5 Precautions:

3) Using a test male terminal, check the female terminals of the circuit being checked for contact tension.

Check each terminal visually for poor contact (possibly caused by dirt, corrosion, rust, entry of foreign object, etc.). At the same time, check to make sure that each terminal is fully inserted in the coupler and locked.

If contact tension is not enough, rectify the contact to increase tension or replace. The terminals must be clean and free of any foreign material which could impede proper terminal contact.

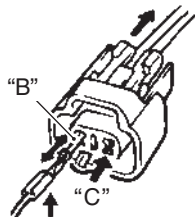

I649G1000027-02

"B": Check contact tension by inserting and removing.
"C": Check each terminal for bend and proper alignment.

4) Using continuity inspect or voltage check procedure as described below, inspect the wire harness terminals for open circuit and poor connection. Locate abnormality, if any.

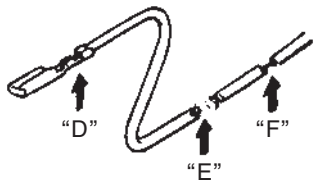

I649G1000028-02

"D": Looseness of crimping
"E": Open
"F": Thin wire (A few strands left)

Continuity check

1) Measure resistance across coupler "B" (between "A" and "C" in figure).

If no continuity is indicated (infinity or over limit), the circuit is open between terminals "A" and "C".

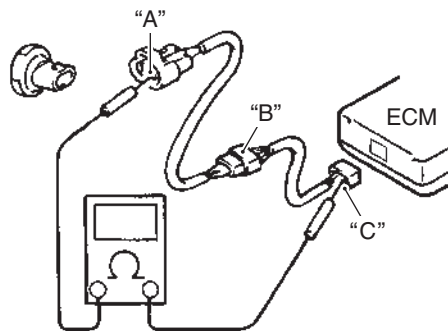

I705H1000006-02

2) Disconnect the coupler "B" and measure resistance between couplers "A" and "B-1".

If no continuity is indicated, the circuit is open between couplers "A" and "B-1". If continuity is indicated, there is an open circuit between couplers "B-2" and "C" or an abnormality in coupler "B-2" or coupler "C".

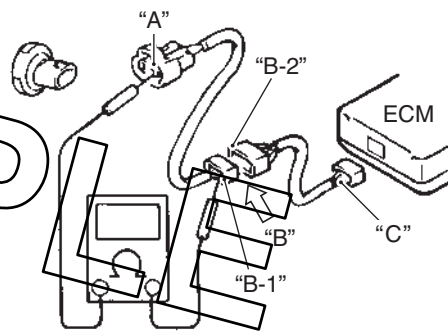

I705H1000010-02

Voltage check

If voltage is supplied to the circuit being checked, voltage check can be used as circuit check.

1) With all connectors/couplers connected and voltage applied to the circuit being checked, measure voltage between each terminal and body ground.

2) If measurements were taken as shown in the figure and results were listed in the following, it means that the circuit is open between terminals "A" and "B".

Voltage between

"A" and body ground: Approx. 5 V

"B" and body ground: Approx. 5 V

"C" and body ground: 0 V